



# PARTS CATALOGUE

## DR2E18 ( J0C2 ) CANADA, EUROPE, OTHERS

---



1TJ0C-100E1

( )

DR2E18  
PARTS CATALOGUE  
©2017 by Yamaha Motor Co., Ltd.  
1st edition, June 2017  
All rights reserved.  
Any reprinting or unauthorized use  
without the written permission of  
Yamaha Motor Co., Ltd.  
is expressly prohibited.  
Printed in Japan.

# FOREWORD

This Parts Catalogue is related to the parts for the model(s) on the cover page. When you are ordering replacement parts, please refer to this Parts Catalogue and quote both part numbers and part names correctly.

1. Modifications or additions which have been made after the issue of the Parts Catalogue will be announced in the Parts News.  
It is advisable that you make the necessary corrections to the Parts Catalogue according to the Parts News.
2. Abbreviations  
The following abbreviations are used in this Parts Catalogue.  
“UR” Use specified parts number.  
“UN” Use as many as needed.  
“AP” Alternate Parts  
“LM” Locally Made (Parts need to be ordered locally)  
“F#” Frame No. (Applicable machine No.)  
“O/S” Over Size
3. The number of components for assembly
  - Parts, which are to be supplied in an assembly, are listed with a dot (.) in front of the part name as shown below.
  - The numeral appearing to the right of each component part indicates the quantity of parts for each assembly unit.

PART NO.	DESCRIPTION	Q'TY	REMARKS
2F5-83310-60	FRONT FLASHER LIGHT ASSY	2	
115-83311-60	.BULB (6V-18W)	1	

4. Applicable colours of graphics are represented in the “REMARKS” as shown below.

PART NO.	DESCRIPTION	Q'TY	REMARKS
2N4-24110-00-X5	FUEL TANK COMP.	2	MXR
3J1-24240-10	.GRAPHIC, FUEL TANK	1	FOR MXR

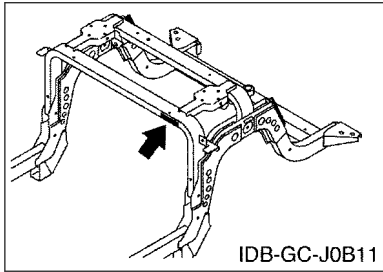
5. Note that the illustrations for reference in finding parts numbers are not to be used for assembling. When assembling, please use the applicable service manual.

6. The asterisk (\*) before a reference number indicates modified items after the first edition.

# FOREWORD

## 7. Applicable Serial No.

Frame Serial No.



## 8. Applicable Colour Code (The (\*) mark shows Model colour.)

Abbreviation	Colour Name	Colour Code
BW1(*)	BLUISH WHITE 1	1571
DNBME(*)	DARK GRAYISH BLUE METALLIC E	0866
DNMC(*)	DARK GRAY METALLIC C	0922
DYNM2(*)	DARK YELLOWISH GRAY METALLIC 2	1509
HTR(*)	HEAT RED	00EY
LNMP(*)	LIGHT GRAY METALLIC P	0925
LN YM8(*)	LIGHT GRAYISH YELLOW ME 8	1047
NYS4(*)	GRAYISH YELLOW SOLID 4	1459
VDGS1(*)	VERY DARK GREEN SOLID 1	0614

## 9. Quantity Column Information

Column No.	Name Of Q'ty Column	Destination
1	J0C2	CANADA, EUROPE, OTHERS

## 10. Applicable Starting Serial No.

Frame Serial No.

Serial No.	Name Of Q'ty Column	Model Code
J0C-100101	J0C2	J0C2

# CONTENTS

## BODY

REAR ARM & SUSPENSION.....	1
FRAME.....	2
FRONT SUSPENSION.....	3
STEERING.....	5
PEDAL WIRE.....	7
PEDAL ASSEMBLY.....	8
BRAKE.....	11

## DRIVE

TRANSAXLE.....	12
WHEEL.....	14
BUMPER.....	15
BODY.....	16
BODY 2.....	18
BODY FITTING.....	20
CARRIER.....	21
SEAT.....	22

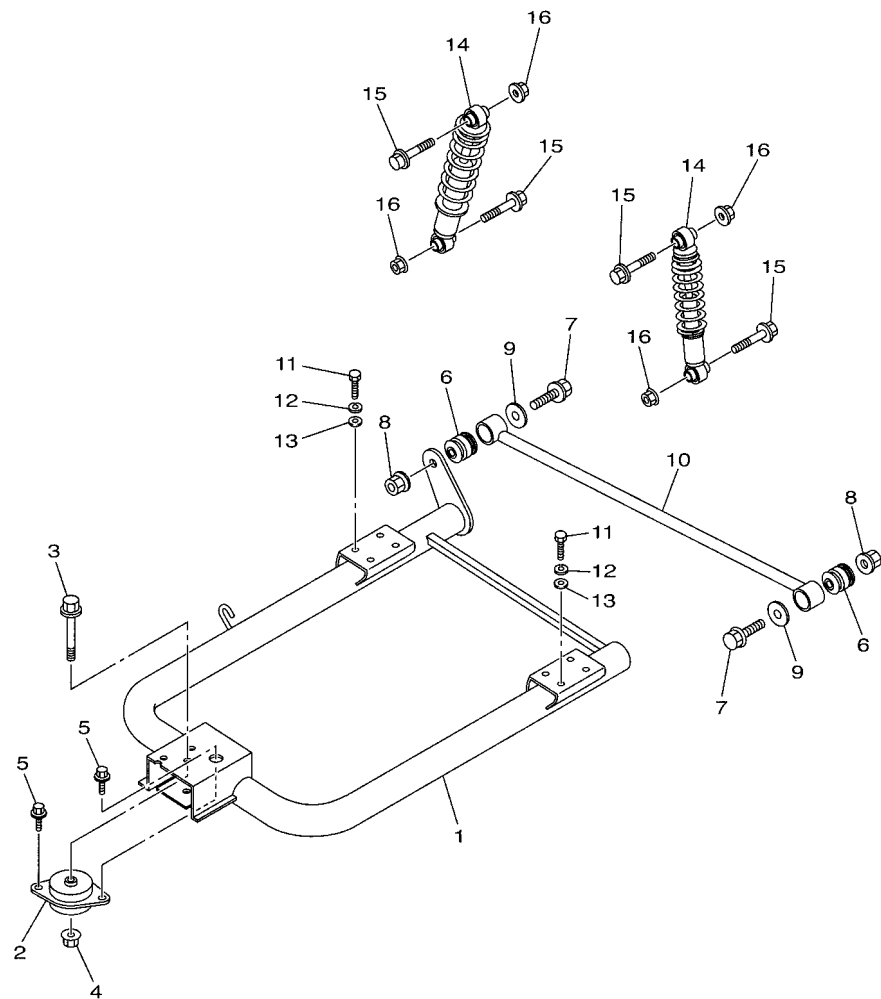
## ELECTRICAL

ELECTRIC MOTOR.....	23
CONTROLLER 1.....	25
ELECTRICAL 1.....	26
BATTERY CHARGER.....	28
ALTERNATE FOR CHASSIS.....	29
ALTERNATE FOR WINDSHIELD.....	30
ALTERNATE FOR SUN ROOF.....	31
ALTERNATE FOR SEAT.....	32

## INDEX

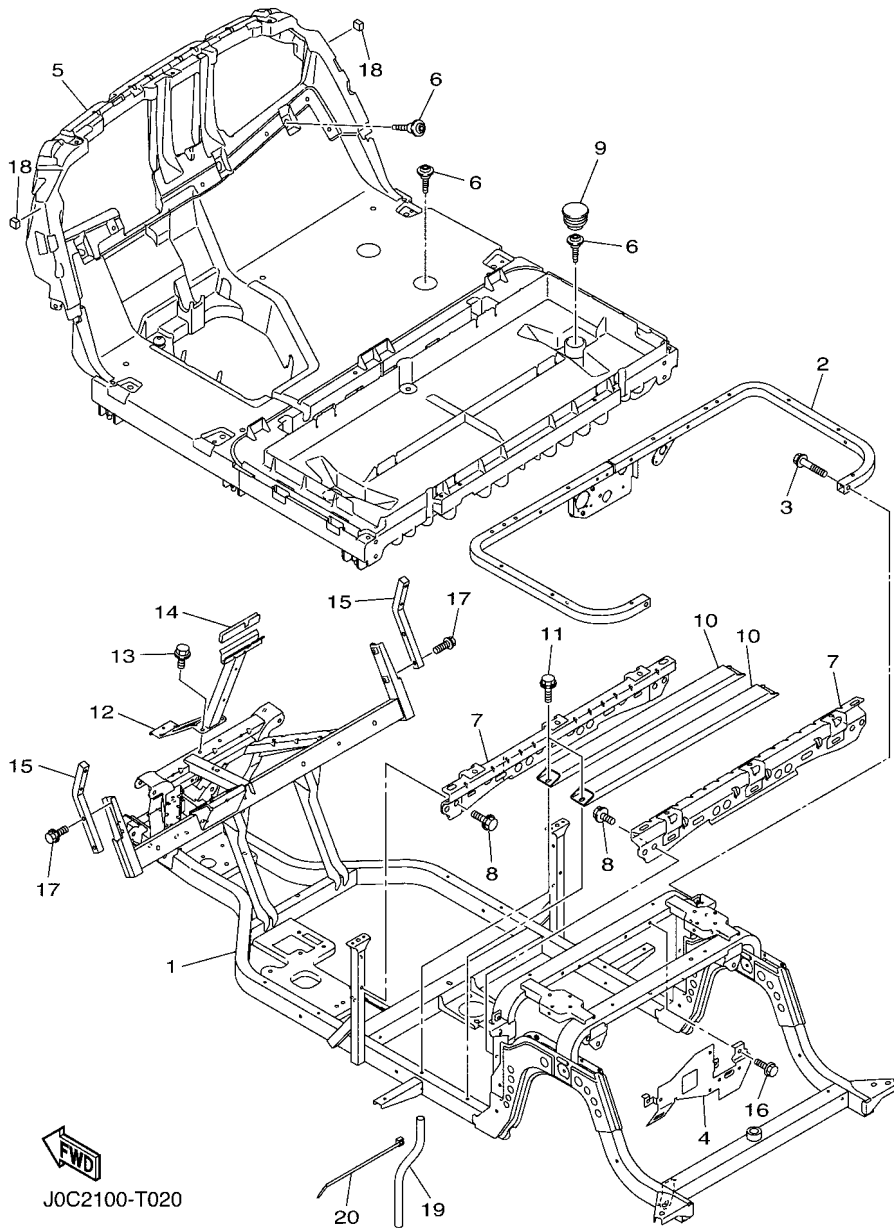
NUMERICAL INDEX.....	33
----------------------	----

**FIG. 1 REAR ARM & SUSPENSION**



J0C1110-S010

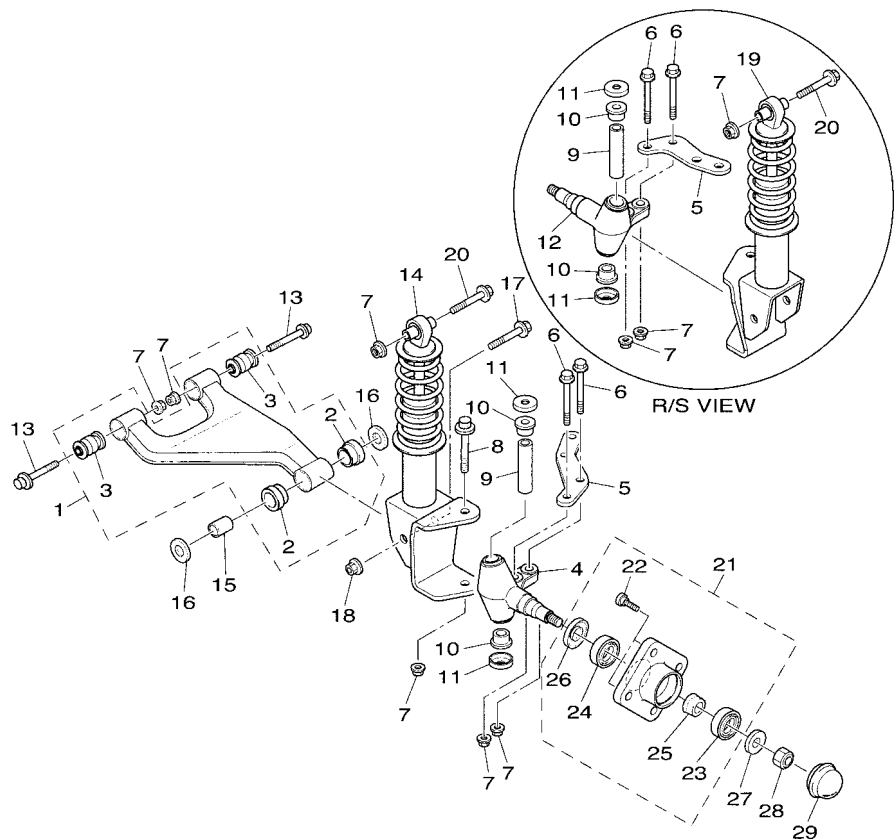
REF. NO.	PART NO.	DESCRIPTION	J0C2				REMARKS
1	J0C-F2110-00	REAR ARM COMP.	1				
2	JN6-F2123-10	BUSH 1	1				
3	90105-13800	BOLT, FLANGE	1				
4	90179-13800	NUT	1				
5	90119-10044	BOLT, WITH WASHER	2				
6	JN6-F2124-10	BUSH 2	2				
7	95812-12065	BOLT, FLANGE	2				
8	95602-12200	NUT, SELF-LOCKING	2				
9	90201-128S4	WASHER, PLATE	2				
10	JW1-F217G-10	ROD, CONNECTING 2	1				
11	97012-10020	BOLT	8				
12	92902-10100	WASHER, SPRING	8				
13	92902-10600	WASHER, PLATE	8				
14	J0C-F2210-00	SHOCK ABSORBER ASSY, REAR	2				
15	95812-10055	BOLT, FLANGE	4				
16	95602-10200	NUT, S/L FLANGE	4				



**FIG. 2 FRAME**

REF. NO.	PART NO.	DESCRIPTION	JOC2				REMARKS
1	J0A-F2501-00	FRAME COMP.	1				
2	J0B-F255G-00	MEMBER, SEAT SUPPORT	1				
3	95812-08040	BOLT, FLANGE	2				
4	JW9-F252M-00	BRACKET, 3	1				
5	J0C-F7411-01	FOOTREST 1	1				
6	J0B-F1738-00	BOLT	9				
7	JW9-F2535-00	STAY, BATTERY 1	2				
8	JW1-F1738-00	BOLT	4				
9	JW9-F2417-00	PLUG	2				
10	JW9-F2198-10	MEMBER, CROSS	2				
11	JW1-F1738-00	BOLT	4				
12	J0B-F258E-00	SUPPORT, FRONT COWL	1				
13	90105-08867	BOLT, FLANGE	2				
14	J0B-F2127-00	SHIM	1				
15	J0B-K816M-00	REAR STORAGE BOX COMP.	2				
16	90105-06831	BOLT, FLANGE	3				
17	90105-088B6	BOLT, FLANGE	4				
18	J0B-K821A-00	PAD, BODY MOUNTING1	2				
19	J0B-F125J-00	PIPE, DRAIN	2				
20	90464-76800	CLAMP	2				

**FIG. 3 FRONT SUSPENSION**

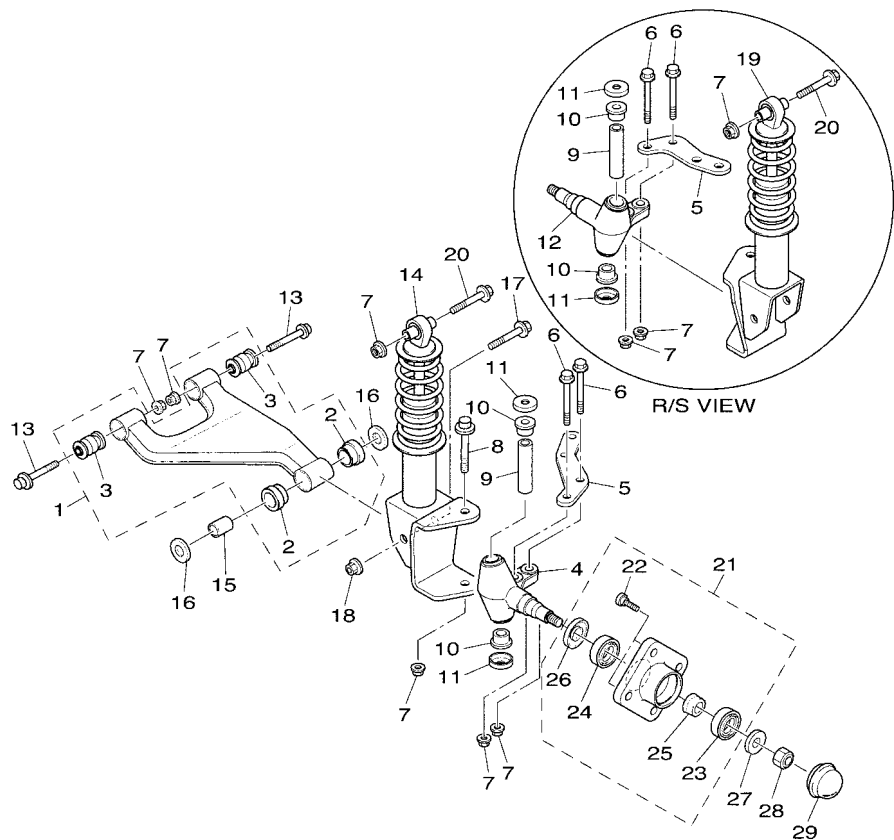


J0C1110-S030

REF. NO.	PART NO.	DESCRIPTION	J0C2				REMARKS
1	J0B-F3570-10	FRONT LOWER ARM COMP. (LEFT)	2				
2	90381-18801	.BUSH, SOLID	2				
3	2HR-23526-00	.BUSH	2				
4	JU0-F3511-20	KNUCKLE, STEERING 1	1				
5	JW1-F3512-00	ARM, KNUCKLE 1	2				
6	90105-10373	BOLT, FLANGE	4				
7	95602-10200	NUT, S/L FLANGE	12				
8	90105-10219	BOLT, FLANGE	2				
9	2NL-23448-00	SPACER	2				
10	90381-17800	BUSH, SOLID	4				
11	2NL-23517-00	COVER, THRUST 1	4				
12	JU0-F3521-20	KNUCKLE, STEERING 2	1				
13	90105-10267	BOLT, FLANGE	4				
14	J0C-F3350-00	SHOCK ABSORBER ASSY	1				
15	90387-12016	COLLAR	2				
16	401-22128-01	COVER, THRUST 1	4				
17	95812-12080	BOLT, FLANGE	2				
18	95612-12100	NUT, U	2				
19	J0C-F3390-00	SHOCK ABSORBER ASSY 2	1				
20	90105-10267	BOLT, FLANGE	2				
21	JW8-F5103-00	HUB BEARING UNIT ASSY	2				
22	90114-12806	.BOLT, SERRATION	4				
23	93306-204X0	.BEARING	1				
24	93306-005Y3	.BEARING	1				
25	90387-241M7	.COLLAR	1				
26	93102-30083	.OIL SEAL	1				
27	90208-14801	WASHER, CONICAL SPRING	2				



**FIG. 3 FRONT SUSPENSION**



REF. NO.	PART NO.	DESCRIPTION	JOC2				REMARKS
28	95602-14100	NUT, U	2				
29	JN6-F5118-01	COVER, HUB DUST	2				



J0C1110-S030

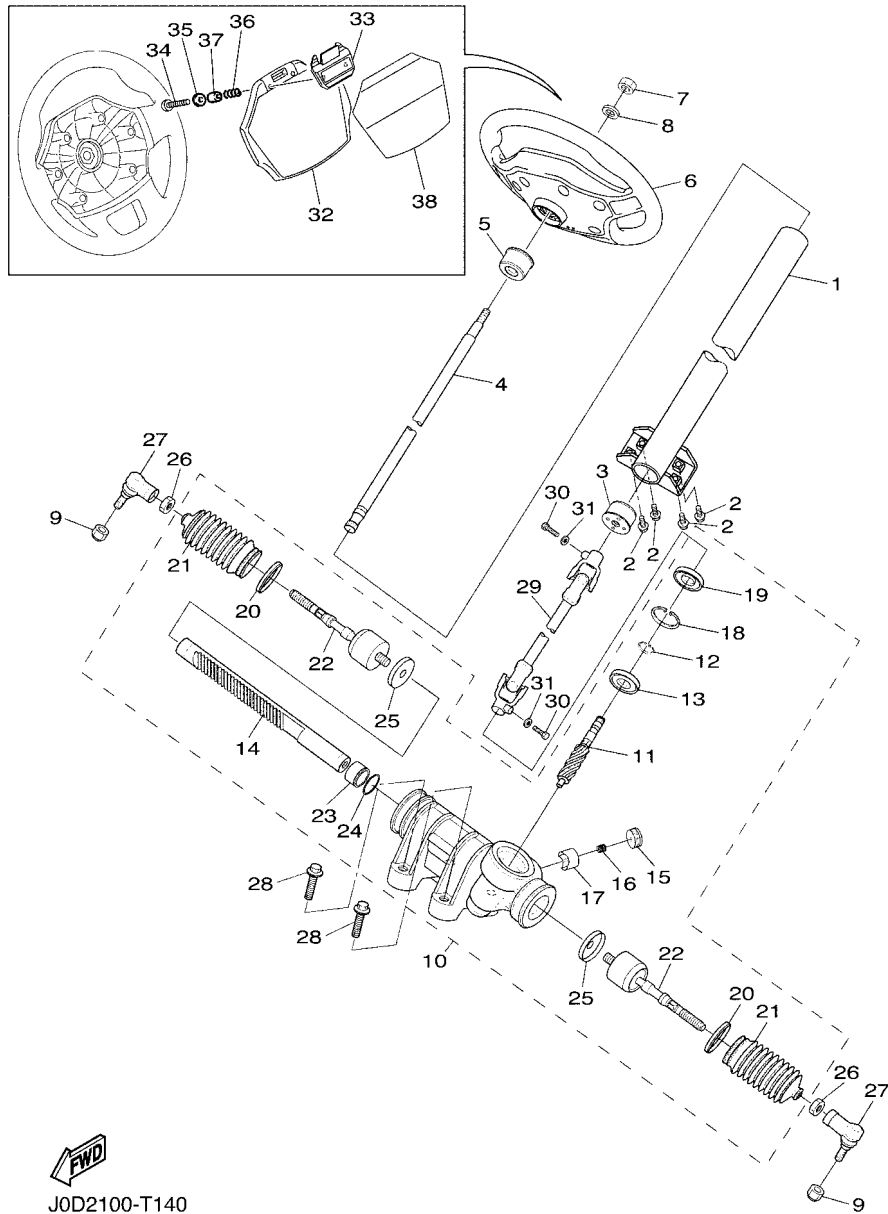
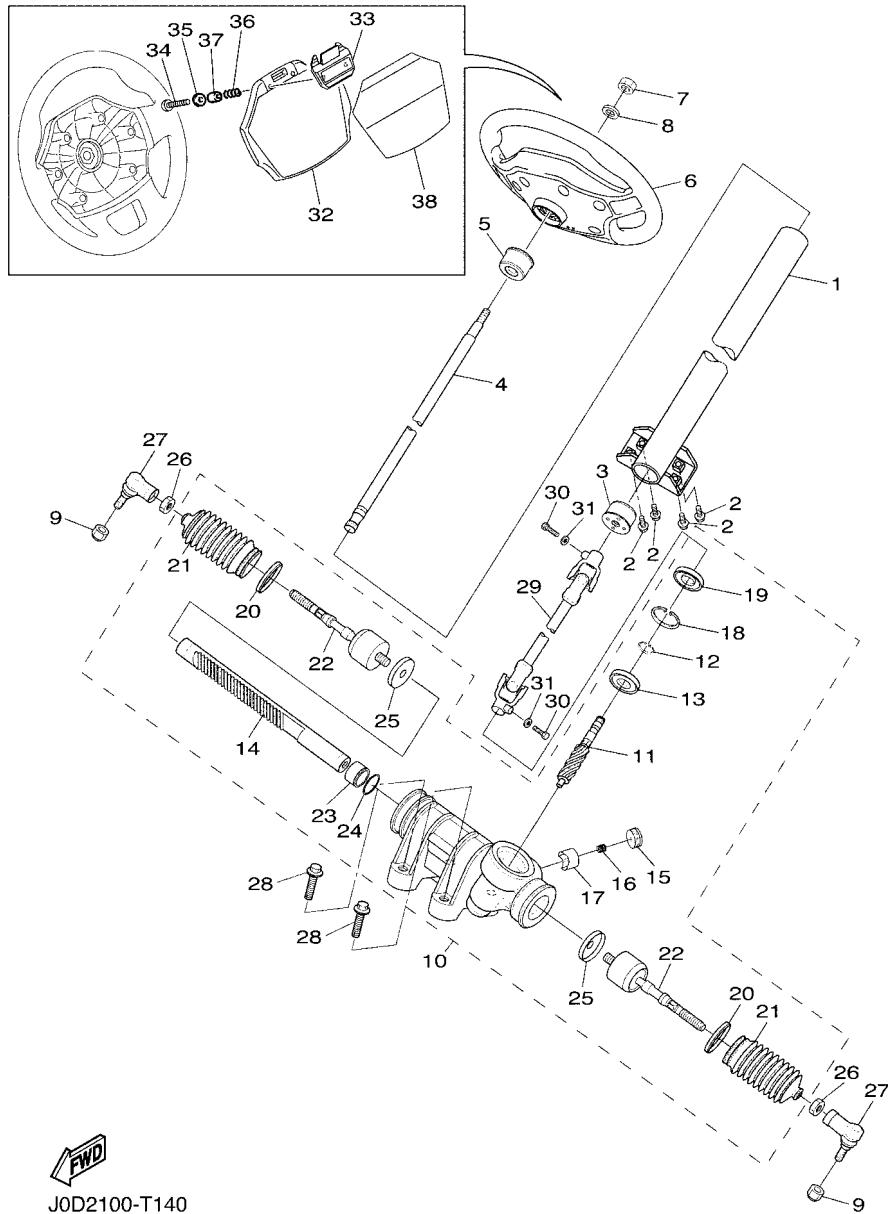


FIG. 4 STEERING

REF. NO.	PART NO.	DESCRIPTION	J0C2				REMARKS
1	JW1-F3811-03	COLUMN, STEERING	1				
2	95812-08020	BOLT, FLANGE	4				
3	JU0-F3857-11	HOLDER	1				
4	JU0-F3828-10	ROD, STEERING	1				
5	JU0-F3857-11	HOLDER	1				
6	J0A-F3838-00	WHEEL, STEERING	1				
7	90185-12008	NUT, SELF-LOCKING	1				
8	92902-12200	WASHER	1				
9	95602-12200	NUT, SELF-LOCKING	2				
10	JW1-F3400-00	STEERING ASSY	1				
11	JW1-F387A-00	.GEAR, PINION	1				
12	JW1-F3183-00	.CIRCLIP	1				
13	JW1-F3812-00	.BEARING, STEERING	1				
14	JW1-F387E-00	.GEAR, RACK	1				
15	5UG-F387G-00	.COVER, ADJUST	1				
16	5UG-F387K-00	.SPRING, PRESSURE	1				
17	5UG-F387F-00	.PAD, PRESSURE	1				
18	5UG-F387J-00	.RING, STOPPER	1				
19	5UG-F3844-00	.SEAL	1				
20	5UG-F3489-00	.BAND	2				
21	5UG-F3527-00	.SEAL, DUST 1	2				
22	JW1-F3837-00	.ROD, TIE 2	2				
23	JW1-F467K-00	.BUSH, CAP	1				
24	JW1-F3866-00	.CIRCLIP	1				
25	JW1-F3894-00	.WASHER, LOCK 1	2				
26	1P0-F3833-00	NUT 1	2				
27	JW8-23841-01	JOINT, UNIVERSAL 1	2				

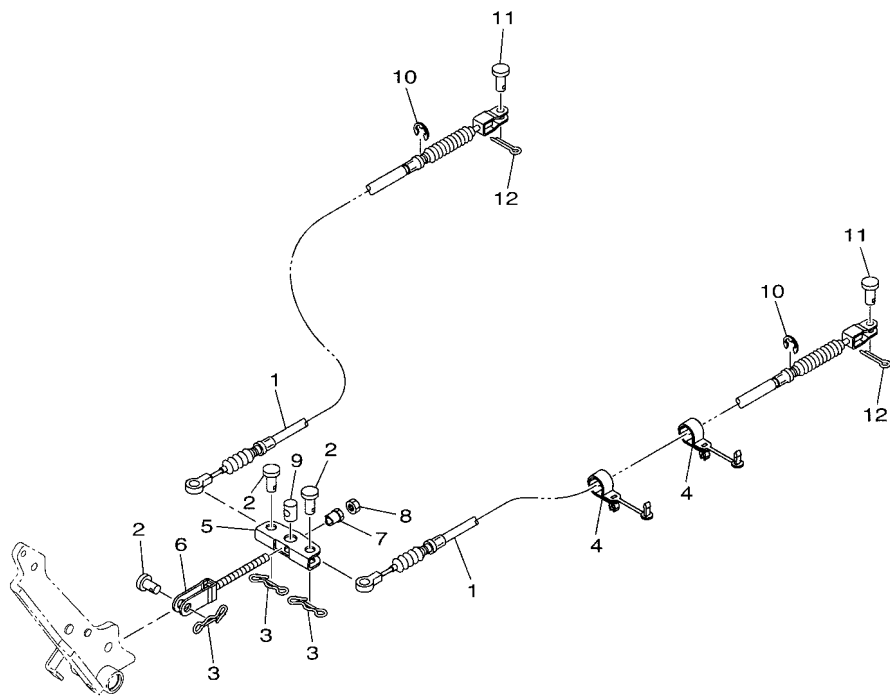


J0D2100-T140

**FIG. 4 STEERING**

REF. NO.	PART NO.	DESCRIPTION	J0C2				REMARKS
28	90105-10847	BOLT, FLANGE	4				
29	JW1-F3822-01	JOINT 1	1				
30	97012-08030	BOLT	2				
31	92902-08600	WASHER, PLATE	2				
32	J0B-K8357-00	HOLDER 1	1				
33	J0B-K8358-00	HOLDER 2	1				
34	J0B-K7387-00	SCREW	2				
35	90201-04810	WASHER, PLATE	2				
36	J0B-K7363-00	SPRING	2				
37	J0B-K7115-00	COLLAR	2				
38	J0B-K7762-10	LABEL, WARNING 2	1				UR ENGLISH/FRENCH
	J0B-K7762-20	LABEL, WARNING 2	1				UR GERMAN/SPANISH

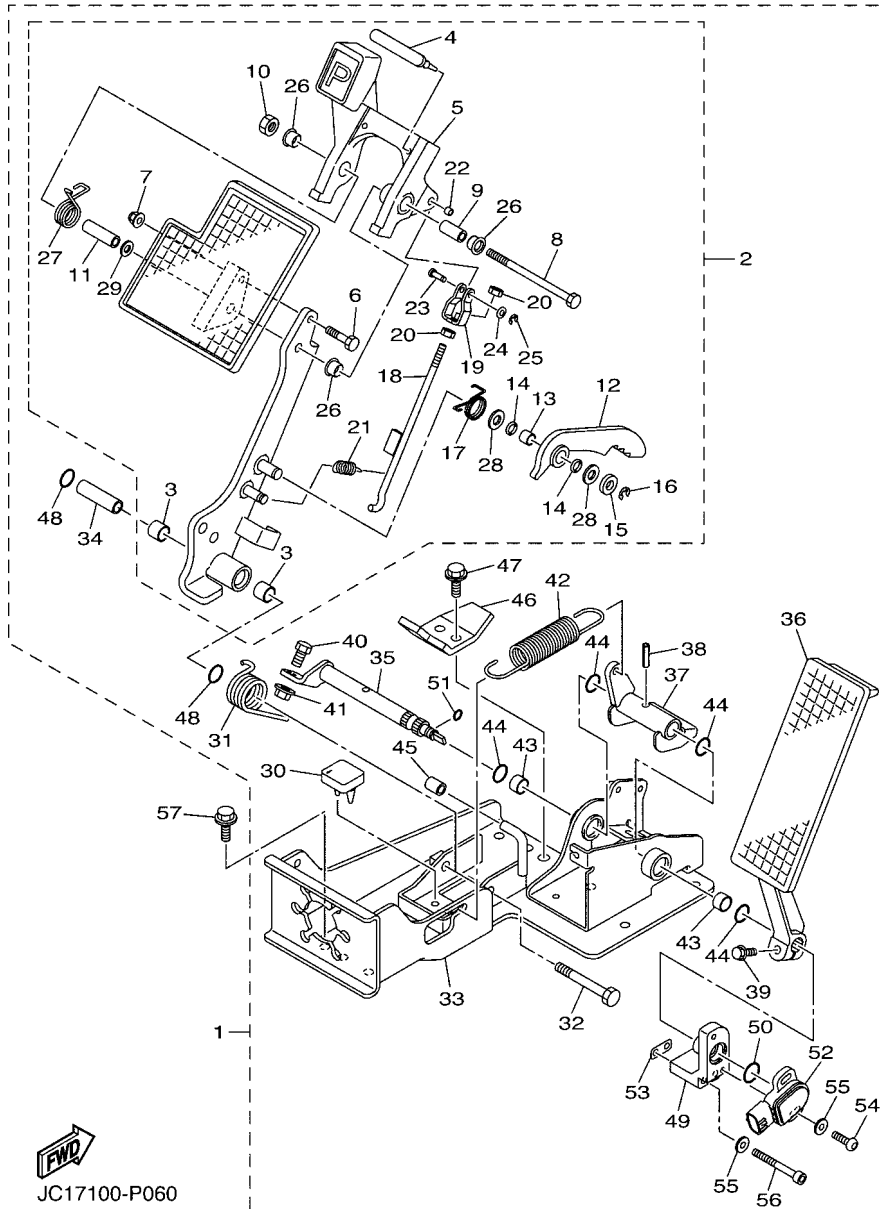
**FIG. 5 PEDAL WIRE**



REF. NO.	PART NO.	DESCRIPTION	JOC2				REMARKS
1	JW9-F6351-10	CABLE, BRAKE	2				
2	91702-10026	PIN, CLEVIS	3				
3	90468-20196	CLIP	3				
4	JW7-F312H-00	CLAMP	4				
5	JW8-F5681-10	EQUALIZER, BRAKE	1				
6	JN6-F5685-01	ROD	1				
7	90179-08822	NUT	1				
8	95307-08700	NUT	1				
9	90249-14129	PIN	1				
10	99001-09600	CIRCLIP	2				
11	91702-08018	PIN, CLEVIS	2				
12	91490-25015	PIN, COTTER	2				

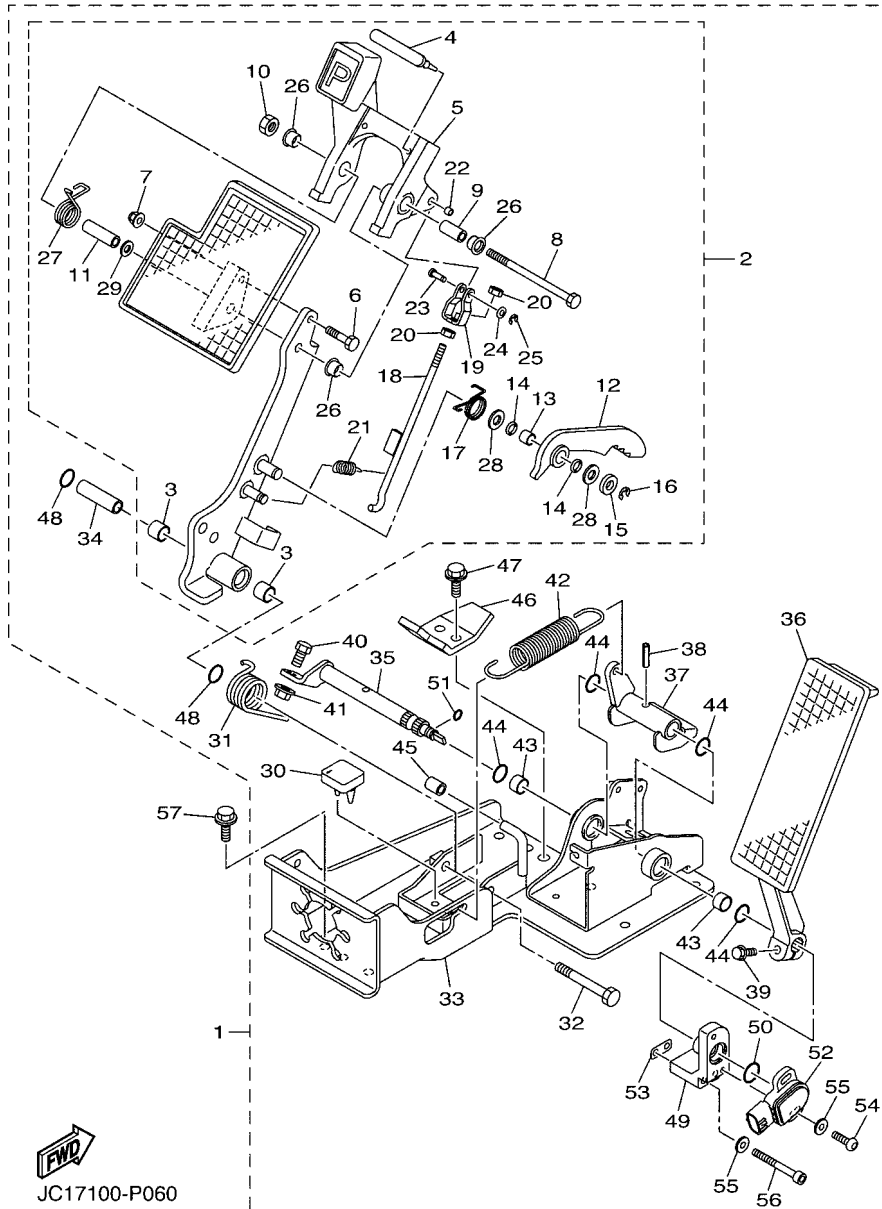


JW97110-R050



**FIG. 6 PEDAL ASSEMBLY**

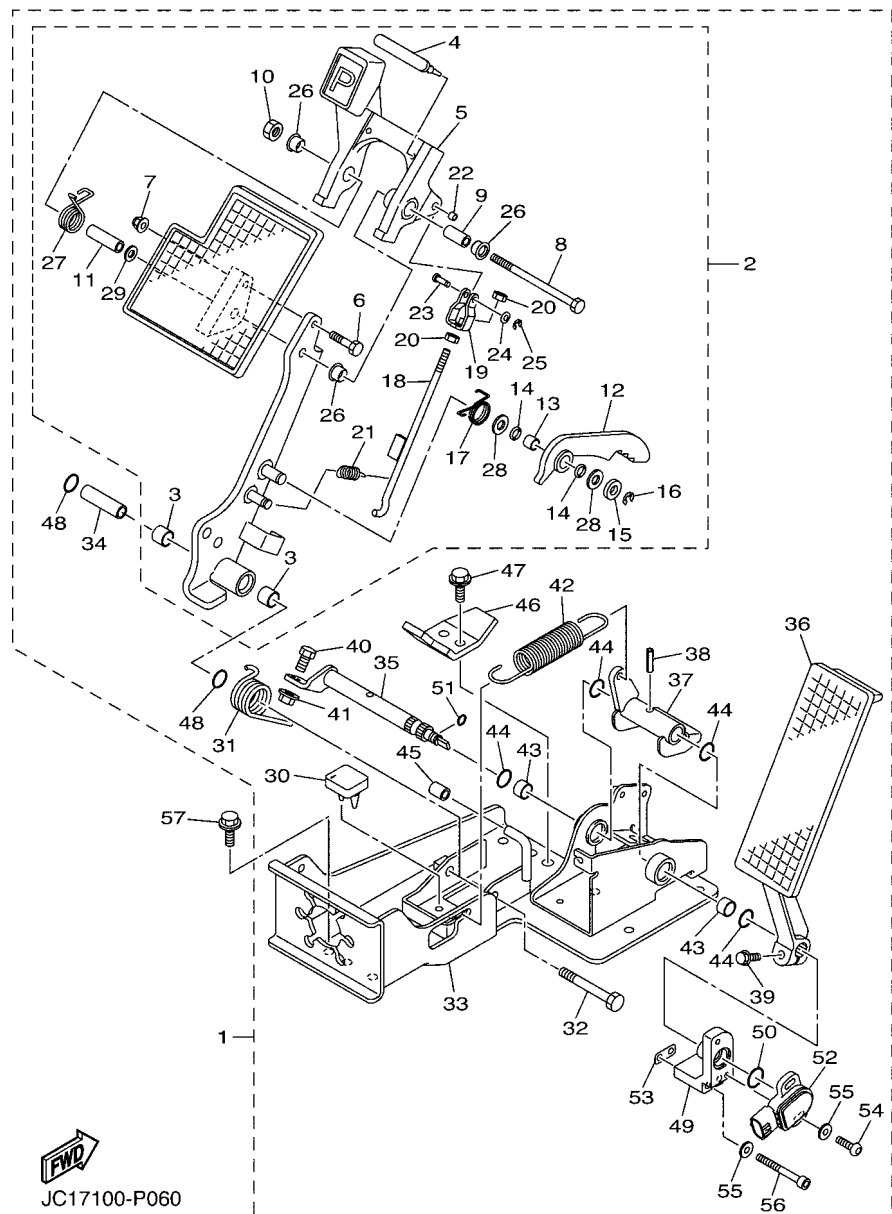
REF. NO.	PART NO.	DESCRIPTION	JOC2				REMARKS
1	JW9-F7850-31	PEDAL ASSY (L.H)	1				
2	JW9-F7200-21	.PEDAL, BRAKE	1				
3	JW8-F7814-21	.BUSH, PEDAL	2				
4	JW9-F5672-00	.PAD, PARKING PEDAL	1				
5	JW9-F5671-00	.PEDAL, PARKING BRAKE	1				
6	JW8-F7117-00	.BOLT, MAIN STAND	1				
7	JW8-F8363-00	.NUT	1				
8	JW8-F7416-00	.BOLT, FOOTREST	1				
9	JW8-F639N-00	.COLLAR	1				
10	JW8-F7218-00	.NUT	1				
11	JW8-F7113-00	.COLLAR, MAIN STAND	1				
12	JW9-F5666-00	.SECTOR, PARKING BRAKE	1				
13	JW8-F7121-00	.BUSH	1				
14	JW9-F7221-00	.SEAL, SHAFT	2				
15	JW8-F7322-00	.WASHER	1				
16	JW8-F3183-00	.CIRCLIP	1				
17	JW8-F7426-01	.SPRING, RETURN	1				
18	JW9-F7231-10	.ROD, BRAKE	1				
19	JW9-F7232-00	.END, ROD 2	1				
20	JW8-F7318-00	.NUT	2				
21	JW8-F6314-00	.SPRING	1				
22	JW8-F639L-00	.BUSH 1	1				
23	JW9-F7228-00	.PIN, JOINT	1				
24	JW8-F8323-00	.WASHER, LEG SHIELD	1				
25	JW8-F5415-00	.CIRCLIP	1				
26	90386-12800	.BUSH	3				
27	JW8-F7825-01	.SPRING, RETURN	1				



JC17100-P060

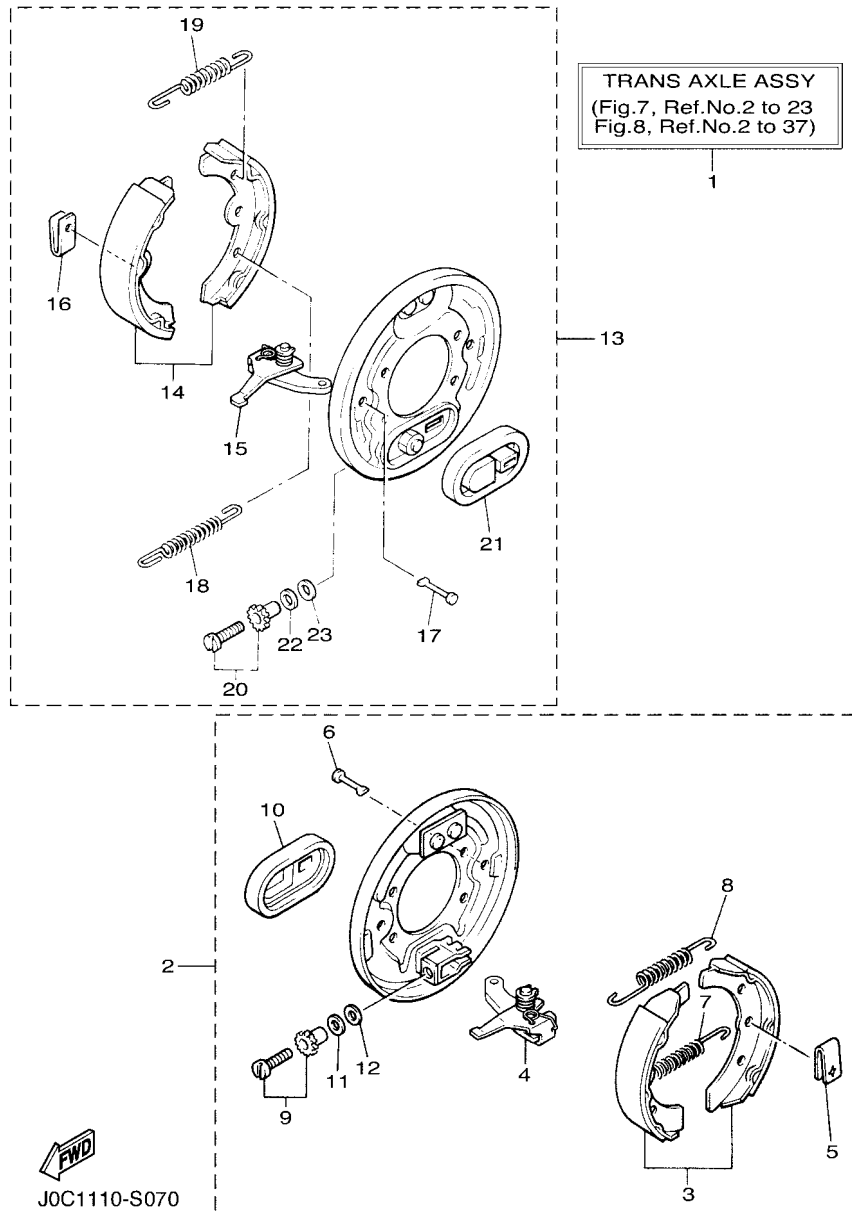
FIG. 6 PEDAL ASSEMBLY

REF. NO.	PART NO.	DESCRIPTION	JOC2				REMARKS
28	JW8-F7119-00	..WASHER	2				
29	JW8-F8319-00	..WASHER	1				
30	JW9-F7245-10	.PAD, BRAKE PEDAL	1				
31	JW8-F7316-01	.SPRING, SIDE STAND	1				
32	JW8-F7217-00	.BOLT	1				
33	JW9-F7445-31	.PLATE 1	1				
34	JW8-F7213-20	.COLLAR	1				
35	JW9-F7853-00	.SHAFT, PEDAL 1	1				
36	JW9-F7871-10	.PEDAL, ACCELERATOR	1				
37	JW9-F7872-20	.ARM, ACCELERATOR PEDAL	1				
38	JW8-F7438-00	.PIN, CLEVIS	1				
39	JW8-F7434-00	.BOLT	1				
40	JW8-F7317-00	.BOLT	1				
41	JW8-F7118-00	.NUT	1				
42	JW8-F815H-01	.SPRING	1				
43	JW8-F7814-21	.BUSH, PEDAL	2				
44	JW8-F4486-00	.O-RING	4				
45	JW9-F5673-00	.DAMPER, BRAKE	1				
46	JW9-F7246-20	.NAIL, BRAKE	1				
47	JW8-F8331-00	.BOLT, LEG SHIELD	2				
48	JW8-F4486-00	.O-RING	2				
49	JW9-F7263-00	.BRACKET 1	1				
50	JW9-F4648-20	.O-RING	1				
51	JW8-F41B8-00	.O-RING	1				
52	JW9-H5885-00	.THROTTLE SENSOR ASSY	1				
53	JW9-F5827-00	.SHIM, CALIPER	1				UR
	JW9-F5827-10	.SHIM, CALIPER	1				UR



**FIG. 6 PEDAL ASSEMBLY**

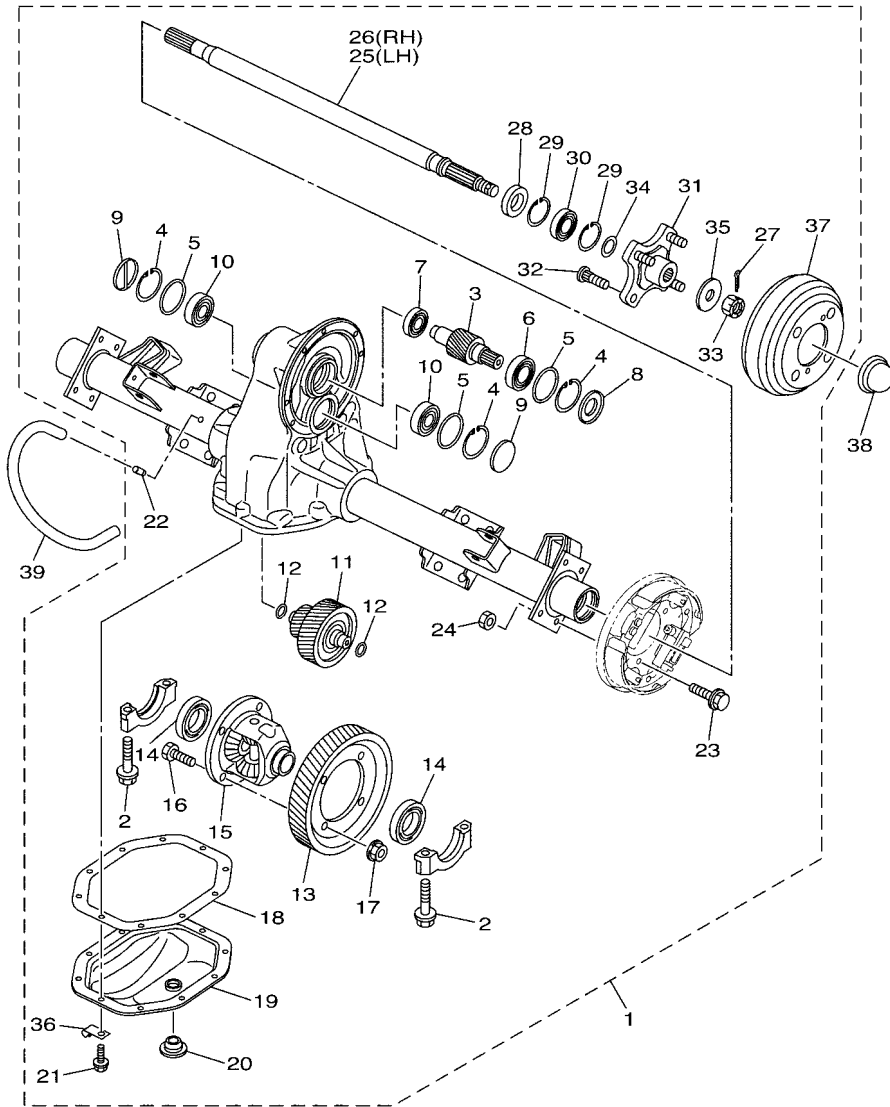
REF. NO.	PART NO.	DESCRIPTION	JOC2				REMARKS
54	JW9-F632G-00	.SCREW	2				
55	90201-05824	.WASHER, PLATE	4				
56	JW8-F7435-00	.BOLT	2				
57	95812-08020	BOLT, FLANGE	6				



**FIG. 7 BRAKE**

REF. NO.	PART NO.	DESCRIPTION	J0C2				REMARKS
1	J0C-G6300-00	TRANS AXLE ASSY	1				
2	JW8-F7290-00	..BACKING PLATE ASSY 2	1				
3	JN9-W2536-00	..BRAKE SHOE SET	1				
4	J38-27205-00	..LEVER ASSY 2	1				
5	JW8-F7281-00	..SPRING, SHOE CLAMP	2				
6	J10-27282-00	..PIN, SHOE HOLD DOWN	2				
7	90506-20281	..SPRING, TENSION	1				
8	90506-14001	..SPRING, TENSION	1				
9	J55-27260-00	..ADJUSTER ASSY	1				
10	JW8-F7286-00	..COVER, DUST	1				
11	90201-121H9	..WASHER, PLATE	1				
12	90201-121H8	..WASHER, PLATE	1				
13	JW8-F7280-00	..BACKING PLATE ASSY 1	1				
14	JN9-W2536-00	..BRAKE SHOE SET	1				
15	J38-27204-00	..LEVER ASSY 1	1				
16	JW8-F7281-00	..SPRING, SHOE CLAMP	2				
17	J10-27282-00	..PIN, SHOE HOLD DOWN	2				
18	90506-20281	..SPRING, TENSION	1				
19	90506-14001	..SPRING, TENSION	1				
20	J55-27270-00	..ADJUSTER ASSY	1				
21	JW8-F7286-00	..COVER, DUST	1				
22	90201-121H9	..WASHER, PLATE	1				
23	90201-121H8	..WASHER, PLATE	1				



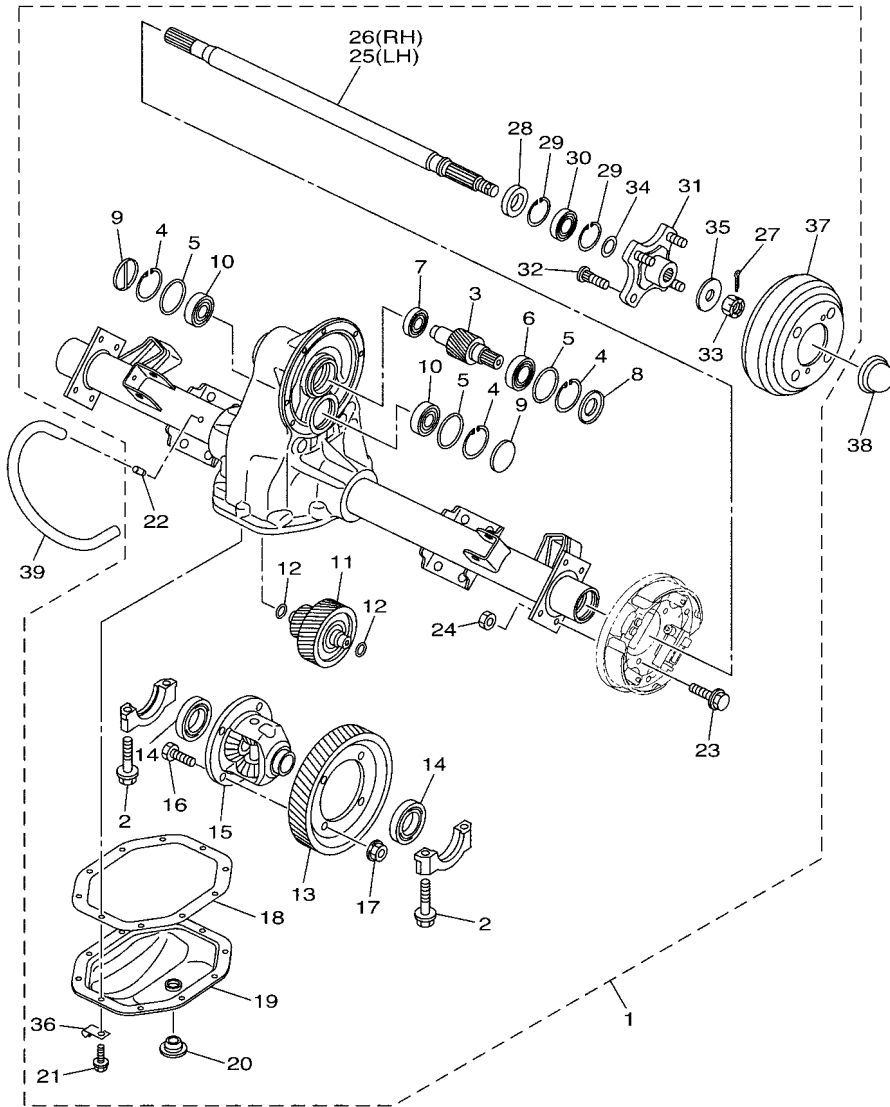


J0C1110-S080

FIG. 8 TRANSAXLE

REF. NO.	PART NO.	DESCRIPTION	J0C2				REMARKS
1	J0C-G6300-00	TRANS AXLE ASSY	1				
2	90105-10840	.BOLT, FLANGE	4				
3	JW9-G6321-00	.SHAFT, INPUT	1				
4	93420-50804	.CIRCLIP	3				
5	93210-478B8	.O-RING	3				
6	93306-005Y1	.BEARING	1				
7	93306-203X1	.BEARING	1				
8	JW9-G6136-00	.SEAL 1	1				
9	JH7-G3396-01	.PLUG, BLIND	2				
10	93306-303Y6	.BEARING	2				
11	JW9-G6350-00	.COUNTER GEAR ASSY	1				
12	93210-148B9	.O-RING	2				
13	JW9-G6421-00	.GEAR, RING	1				
14	93306-007Y0	.BEARING	2				
15	JW9-G6410-00	.DIFFERENTIAL ASSY.	1				
16	90101-10854	.BOLT	4				
17	90170-10840	.NUT	4				
18	JW9-G631A-00	.GSKT., CASE	1				
19	JW9-G6312-00	.CASE, TRANSMISSION 2	1				
20	JN3-G6432-00	.STOPPER	1				
21	90101-08856	.BOLT	10				
22	JW8-G5378-00	.NIPPLE, HOSE	1				
23	90101-08855	.BOLT	8				
24	90170-08841	.NUT	8				
25	JR1-G6511-00	.SHAFT, REAR AXLE 1 (L.H)	1				
26	JR1-G6512-00	.SHAFT, REAR AXLE 2 (R.H)	1				
27	91490-30030	.PIN. COTTER	2				

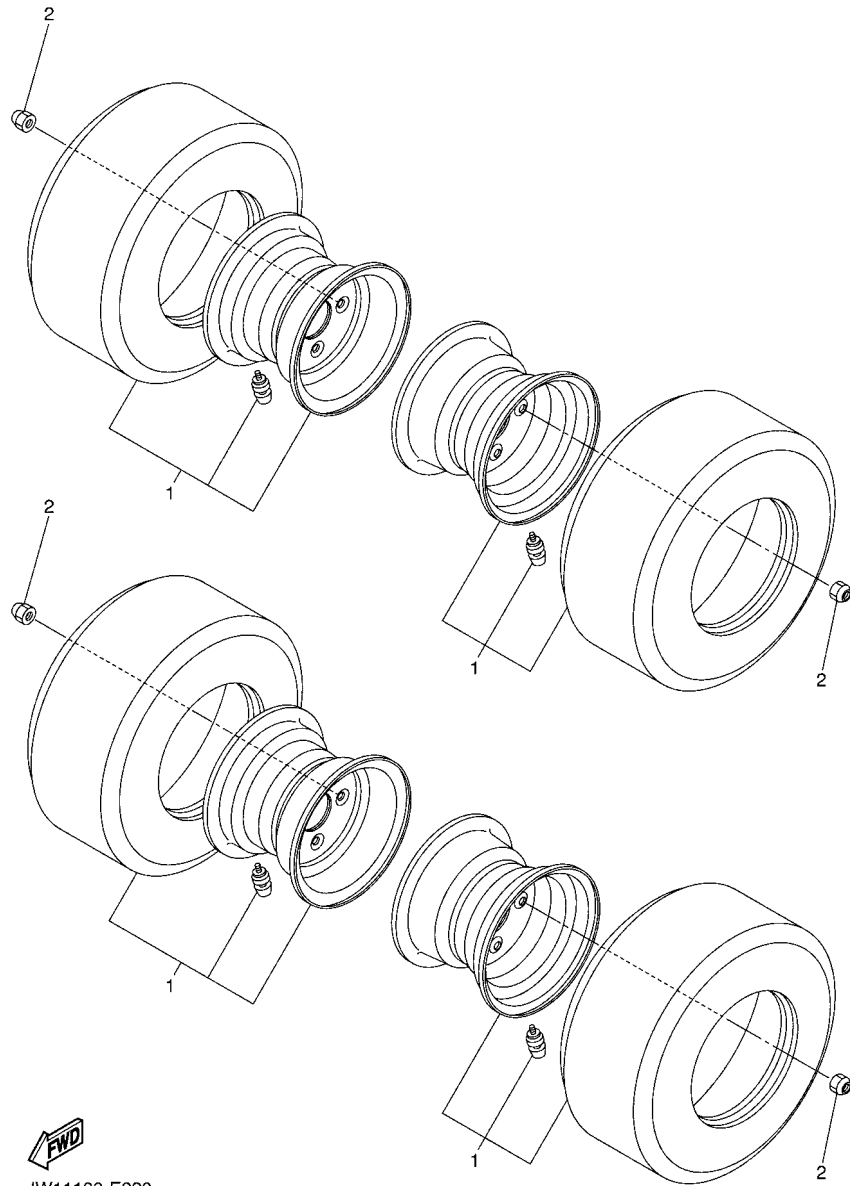
**FIG. 8 TRANSAXLE**



REF. NO.	PART NO.	DESCRIPTION	JOC2				REMARKS
28	93101-24822	.OIL SEAL	2				
29	93420-44805	.CIRCLIP	4				
30	93306-00440	.BEARING	2				
31	JW8-G6514-00	.HUB, REAR AXLE	2				
32	JW8-G4178-00	.BOLT, STUD	8				
33	JW8-G5244-00	.NUT	2				
34	JW8-G2535-00	.WASHER, THRUST	2				
35	JW8-G2536-00	.WASHER, THRUST 2	2				
36	JW8-G2756-00	.STAY, CLAMP	1				
37	JW8-G6521-00	.DRUM	2				
38	JW8-F5118-00	COVER, HUB DUST	2				
39	JW8-G2541-00	PIPE 1	1				



JOC1110-S080

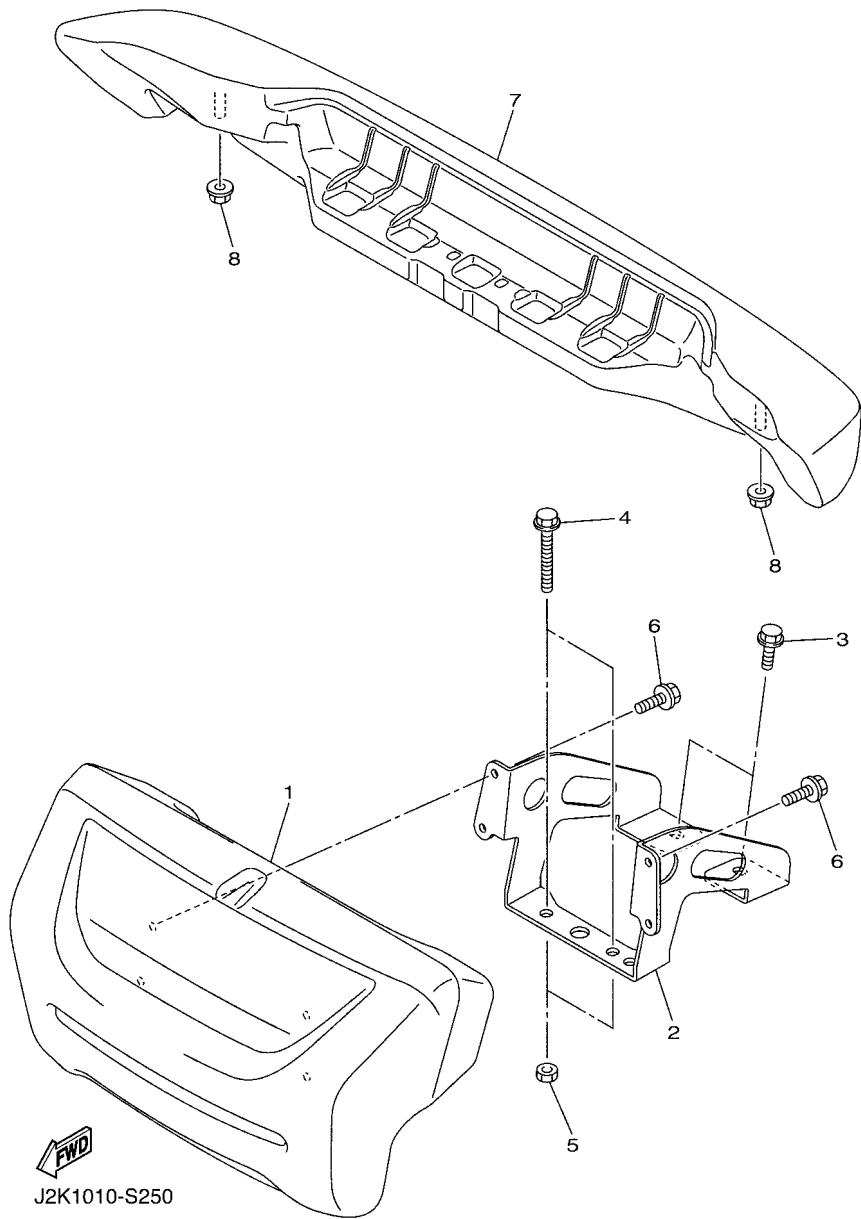


JW11100-E220

FIG. 9 WHEEL

REF. NO.	PART NO.	DESCRIPTION	JOC2				REMARKS
1	JW1-F5100-01	WHEEL ASSY (18X8.50-8-4PLY)	4				
2	90179-12262	NUT	16				

**FIG. 10 BUMPER**



REF. NO.	PART NO.	DESCRIPTION	JOC2				REMARKS
1	J0B-K7510-01	FRONT BUMPER COMP.	1				
2	J0B-K8164-00	STAY, FRONT BUMPER (L.H)	1				
3	95812-08016	BOLT, FLANGE	2				
4	95812-08050	BOLT, FLANGE	2				
5	95302-08700	NUT, HEXAGON	2				
6	95822-06012	BOLT, FLANGE	4				
7	J0B-K7540-00	REAR BUMPER COMP.	1				
8	95602-10200	NUT, S/L FLANGE	2				

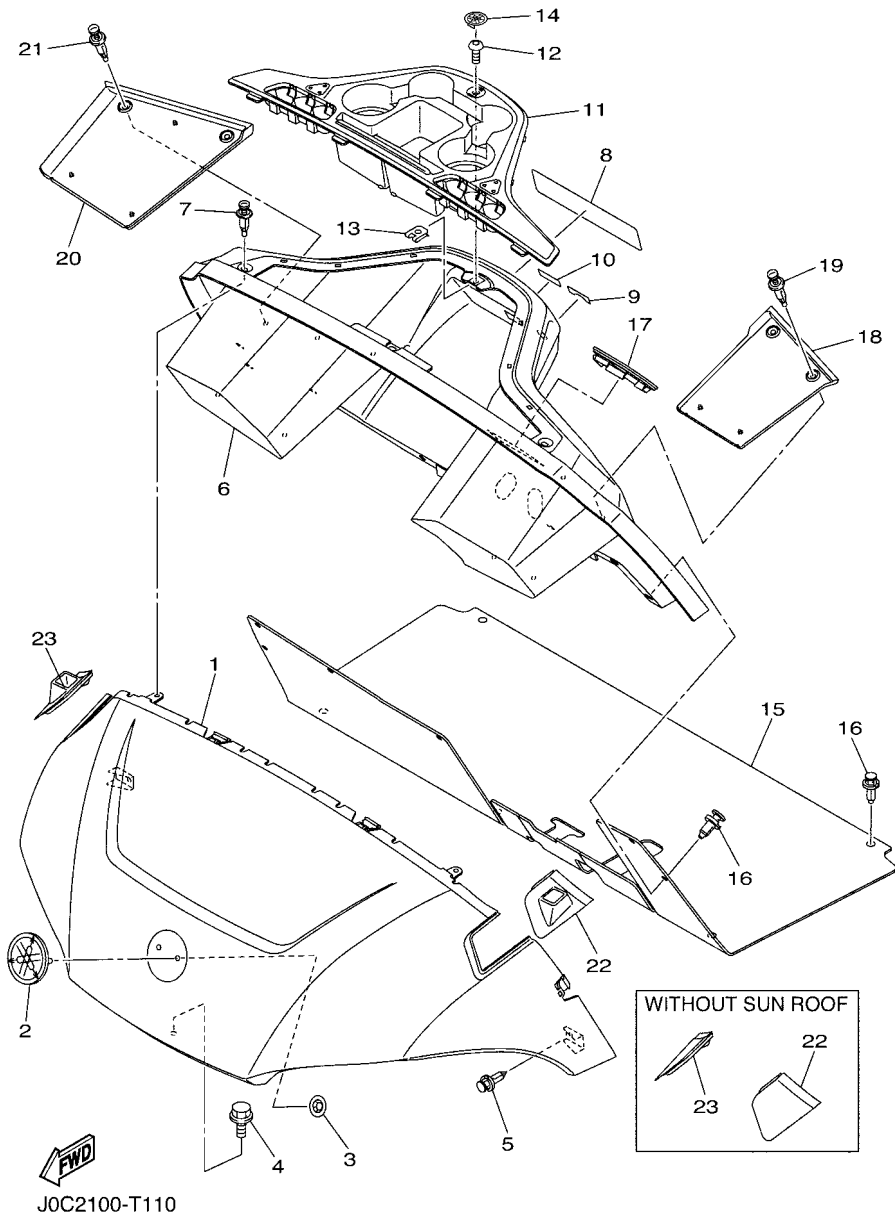
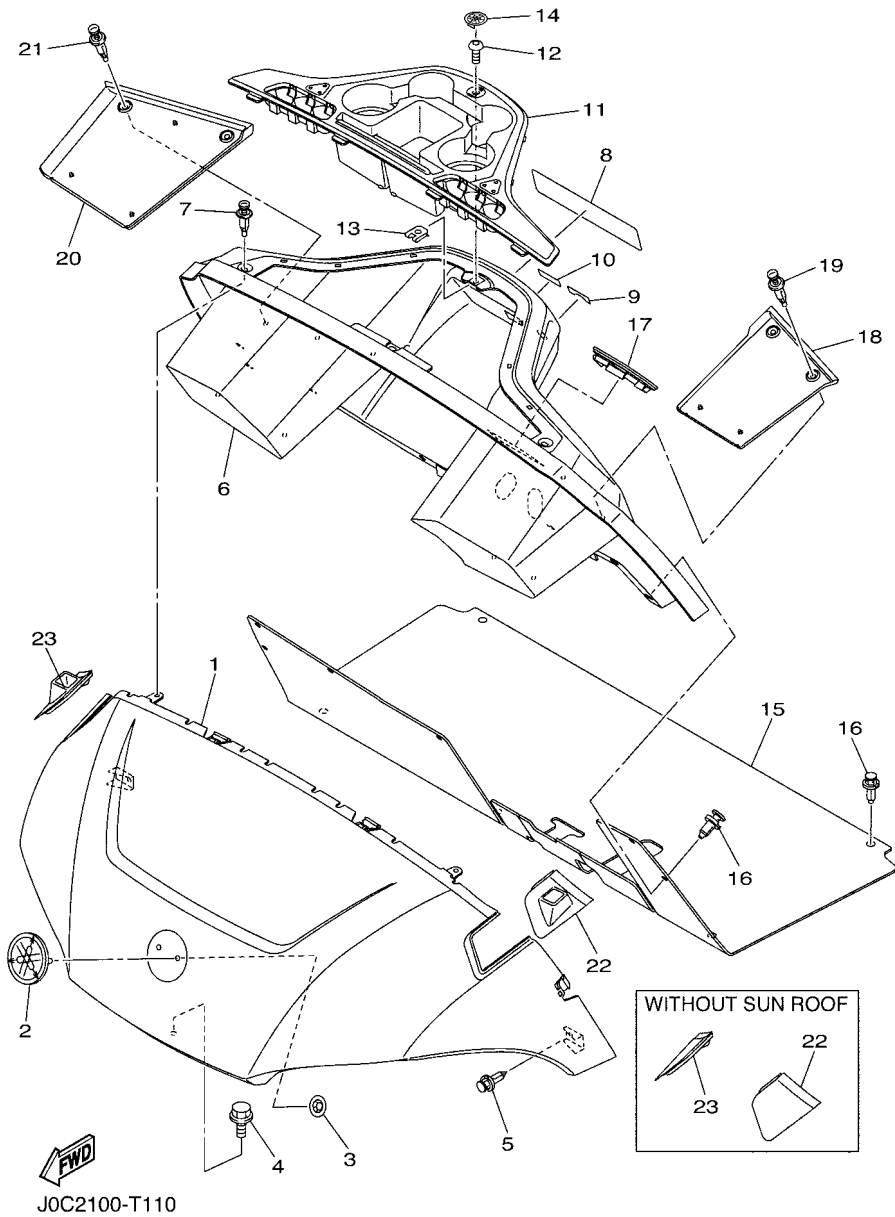


FIG. 11 BODY

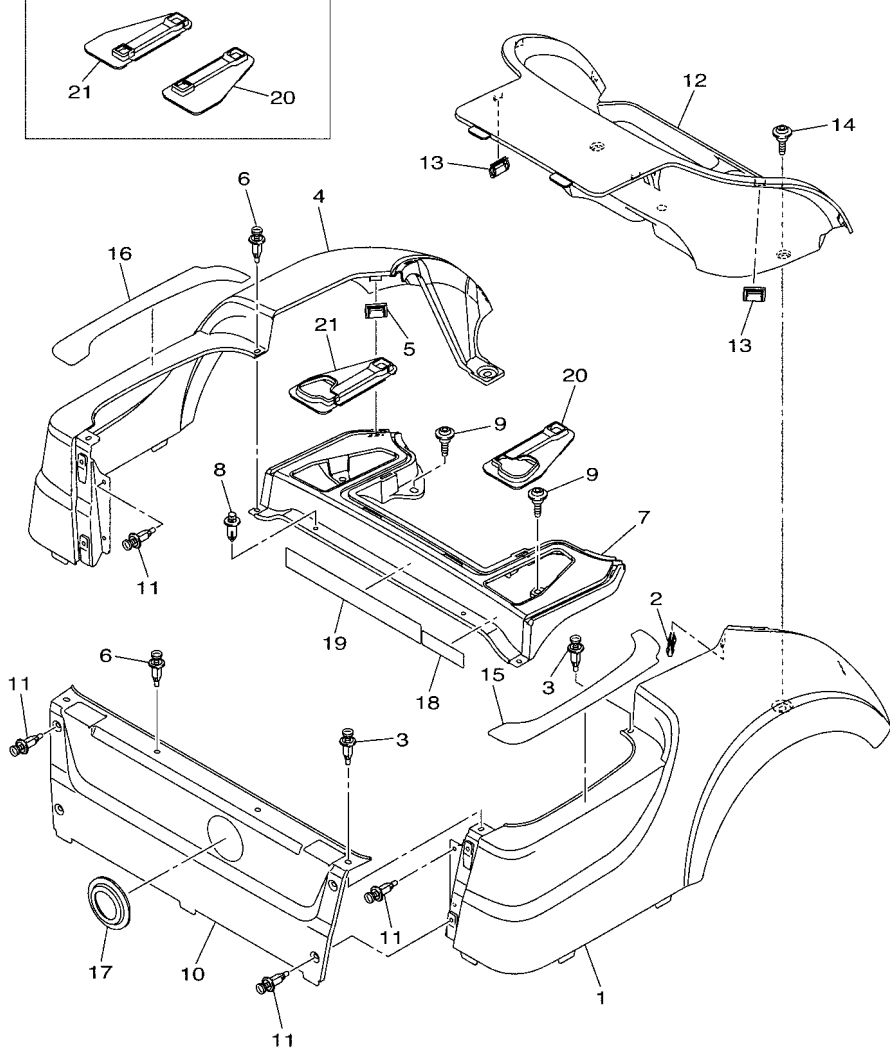
REF. NO.	PART NO.	DESCRIPTION	J0C2		REMARKS
1	J0B-K8115-A0	COWL, FRONT	1		UR FOR BW1
	J0B-K8115-10	COWL, FRONT	1		UR FOR VDGS1
	J0B-K8115-00	COWL, FRONT	1		UR FOR DNBME
	J0B-K8115-20	COWL, FRONT	1		UR FOR LNYM8
	J0B-K8115-30	COWL, FRONT	1		UR FOR LNMP
	J0B-K8115-40	COWL, FRONT	1		UR FOR DYNM2
	J0B-K8115-B0	COWL, FRONT	1		UR FOR NYS4
	J0B-K8115-50	COWL, FRONT	1		UR FOR HTR
	J0B-K8115-60	COWL, FRONT	1		UR FOR DNMC
2	J0B-F4161-00	EMBLEM 1	1		
3	JU0-K7573-00	NUT, SPECIAL	2		
4	90105-06831	BOLT, FLANGE	1		
5	90269-06804	RIVET	2		
6	J0B-K8114-01	PANEL, FRONT	1		UR FOR CAN
	J0C-K8114-01	PANEL, FRONT	1		UR EXCEPT FOR CAN
7	90269-07805	RIVET	3		
8	J0B-K7768-00	LABEL, WARNING 8	1		UR ENGLISH
	J0B-K7768-10	LABEL, WARNING 8	1		UR ENGLISH/FRENCH
	J0B-K7768-20	LABEL, WARNING 8	1		UR GERMAN/SPANISH
9	J0B-K8282-10	PLATE, SWITCH PANEL	1		
10	J0C-K7741-10	INDICATOR 1	1		
11	J0B-K835E-00	HOLDER, BEVERAGE	1		
12	90111-05805	BOLT, HEX. SOCKET BUTTON	1		
13	90183-05008	NUT, SPRING	1		
14	J0B-H2370-00	PLUG CAP ASSY	1		
15	J0B-K8233-00	MAT, MAIN FLOOR 3	1		
16	90269-09003	RIVET	12		



**FIG. 11 BODY**

REF. NO.	PART NO.	DESCRIPTION	J0C2			REMARKS
17	J0B-K8273-10	COVER, HOLE	1			
18	J0B-K8243-00	MAT, REAR BODY SIDE (LH)	1			
19	90269-07805	RIVET	2			
20	J0B-K8244-00	MAT, REAR BODY SIDE (RH)	1			
21	90269-07805	RIVET	2			
22	J0B-K832F-10	GROMMET, ROOF SUPPORT 1	1			WITH SUN ROOF
	J0B-K832F-00	GROMMET, ROOF SUPPORT 1	1			WITHOUT SUN ROOF
23	J0B-K832G-10	GROMMET, ROOF SUPPORT 2	1			WITH SUN ROOF
	J0B-K832G-00	GROMMET, ROOF SUPPORT 2	1			WITHOUT SUN ROOF

WITHOUT SUN ROOF

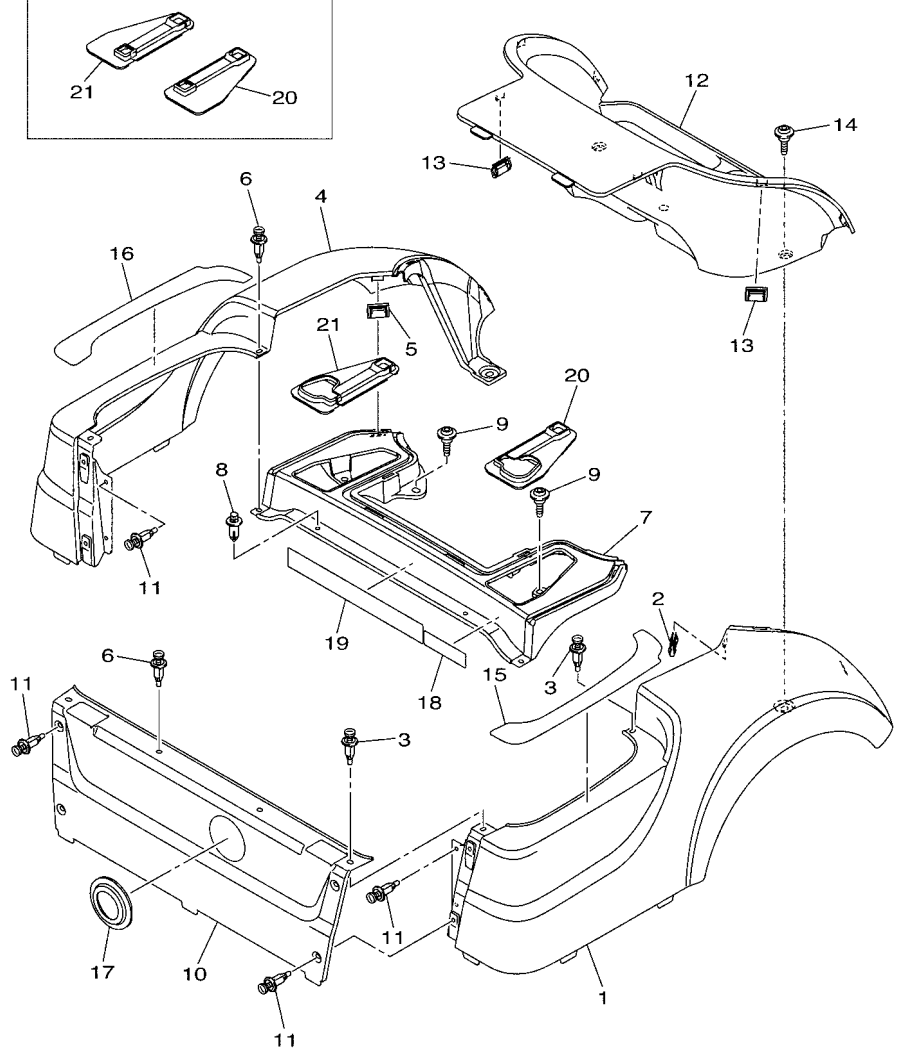


J0C1110-S120

FIG. 12 BODY 2

REF. NO.	PART NO.	DESCRIPTION	J0C2	REMARKS
1	J0B-K8111-A0	PANEL, BODY SHELL	1	UR FOR BW1
	J0B-K8111-10	PANEL, BODY SHELL	1	UR FOR VDGS1
	J0B-K8111-00	PANEL, BODY SHELL	1	UR FOR DNBME
	J0B-K8111-20	PANEL, BODY SHELL	1	UR FOR LNYM8
	J0B-K8111-30	PANEL, BODY SHELL	1	UR FOR LNMP
	J0B-K8111-40	PANEL, BODY SHELL	1	UR FOR DYNM2
	J0B-K8111-B0	PANEL, BODY SHELL	1	UR FOR NYS4
	J0B-K8111-50	PANEL, BODY SHELL	1	UR FOR HTR
	J0B-K8111-60	PANEL, BODY SHELL	1	UR FOR DNMC
2	J0B-F3447-00	CLIP	1	
3	90269-07805	RIVET	3	
4	J0B-K8112-A0	PANEL, BODY SHELL	1	UR FOR BW1
	J0B-K8112-10	PANEL, BODY SHELL	1	UR FOR VDGS1
	J0B-K8112-00	PANEL, BODY SHELL	1	UR FOR DNBME
	J0B-K8112-20	PANEL, BODY SHELL	1	UR FOR LNYM8
	J0B-K8112-30	PANEL, BODY SHELL	1	UR FOR LNMP
	J0B-K8112-40	PANEL, BODY SHELL	1	UR FOR DYNM2
	J0B-K8112-B0	PANEL, BODY SHELL	1	UR FOR NYS4
	J0B-K8112-50	PANEL, BODY SHELL	1	UR FOR HTR
	J0B-K8112-60	PANEL, BODY SHELL	1	UR FOR DNMC
5	J0B-F3447-00	CLIP	1	
6	90269-07805	RIVET	3	
7	J0B-K819H-00	SHELL, REAR BODY	1	
8	JW7-K7329-00	RIVET	2	
9	J0B-F1738-00	BOLT	4	
10	J0C-K8141-A0	PANEL, INTERMEDIATE BODY	1	UR FOR BW1
	J0C-K8141-10	PANEL, INTERMEDIATE BODY	1	UR FOR VDGS1

WITHOUT SUN ROOF



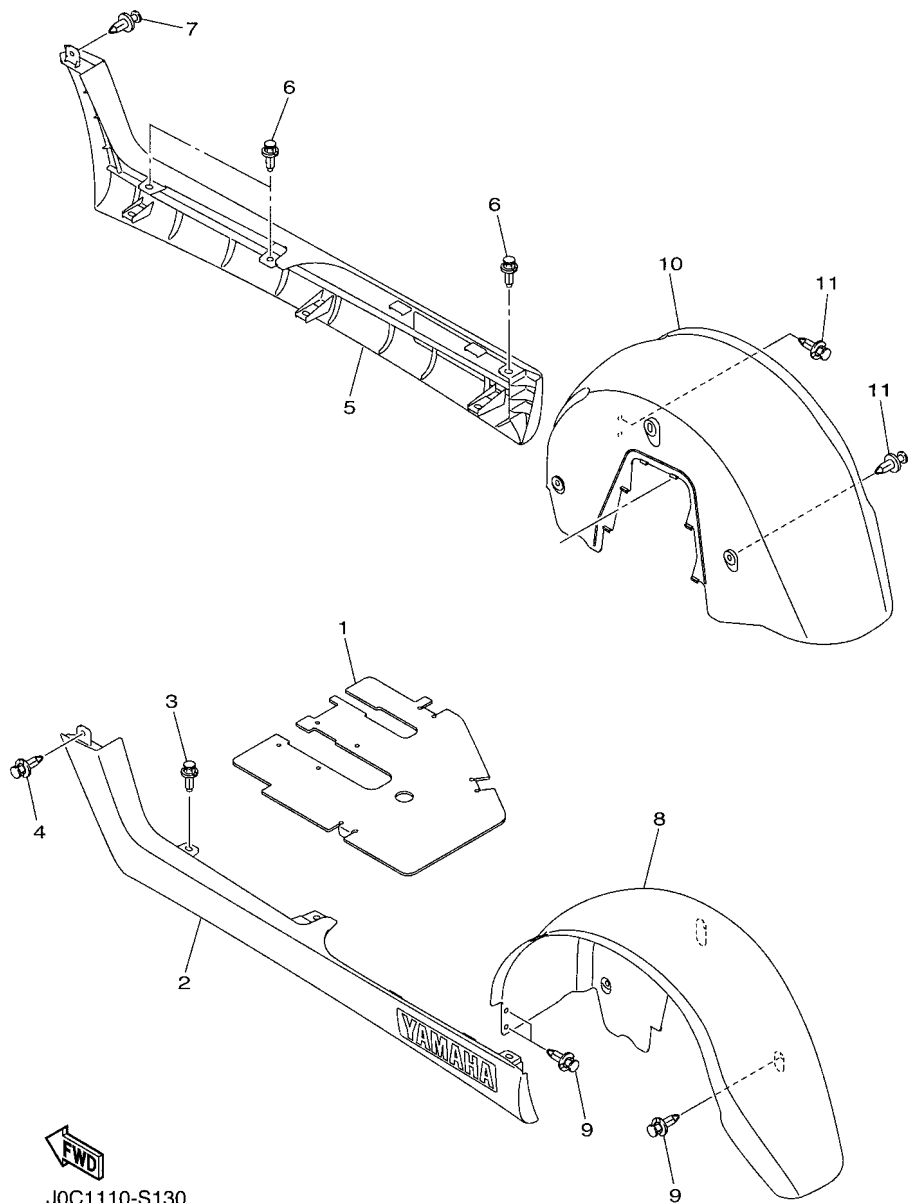
J0C1110-S120

FIG. 12 BODY 2

REF. NO.	PART NO.	DESCRIPTION	J0C2			REMARKS
10	J0C-K8141-00	PANEL, INTERMEDIATE BODY	1			UR FOR DNBME
	J0C-K8141-20	PANEL, INTERMEDIATE BODY	1			UR FOR LNYM8
	J0C-K8141-30	PANEL, INTERMEDIATE BODY	1			UR FOR LNMP
	J0C-K8141-40	PANEL, INTERMEDIATE BODY	1			UR FOR DYNM2
	J0C-K8141-B0	PANEL, INTERMEDIATE BODY	1			UR FOR NYS4
	J0C-K8141-50	PANEL, INTERMEDIATE BODY	1			UR FOR HTR
	J0C-K8141-60	PANEL, INTERMEDIATE BODY	1			UR FOR DNMC
11	90269-07805	RIVET	8			
12	J0B-K8237-02	COVER, REAR FLOOR	1			
13	J0B-F3447-00	CLIP	4			
14	J0B-F1738-00	BOLT	2			
15	J0B-F2873-01	SEAL 1	1			
16	J0B-F2874-01	SEAL 2	1			
17	J0C-K827A-00	GUIDE 1	1			
18	J0C-K8298-00	PLATE, CAUTION 2	1			UR ENGLISH/FRENCH
	J0C-K8298-10	PLATE, CAUTION 2	1			UR GERMAN/SPANISH
19	JW9-K8297-20	PLATE, CAUTION 1	1			UR ENGLISH/FRENCH
	JW9-K8297-30	PLATE, CAUTION 1	1			UR GERMAN/SPANISH
20	J0B-K817H-10	TRIM, SIDE PANEL 1	1			WITH SUN ROOF
	J0B-K817H-00	TRIM, SIDE PANEL 1	1			WITHOUT SUN ROOF
21	J0B-K817J-10	TRIM, SIDE PANEL 2	1			WITH SUN ROOF
	J0B-K817J-00	TRIM, SIDE PANEL 2	1			WITHOUT SUN ROOF

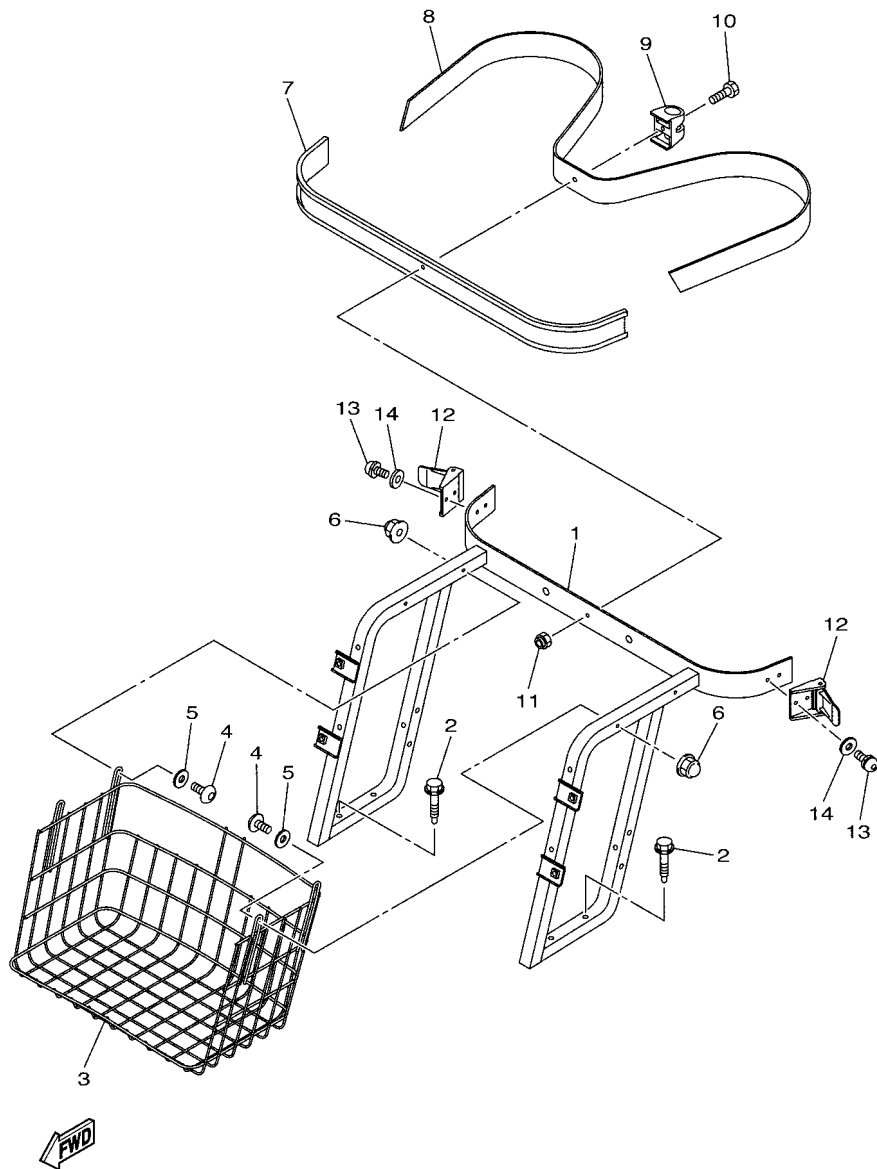


**FIG. 13 BODY FITTING**



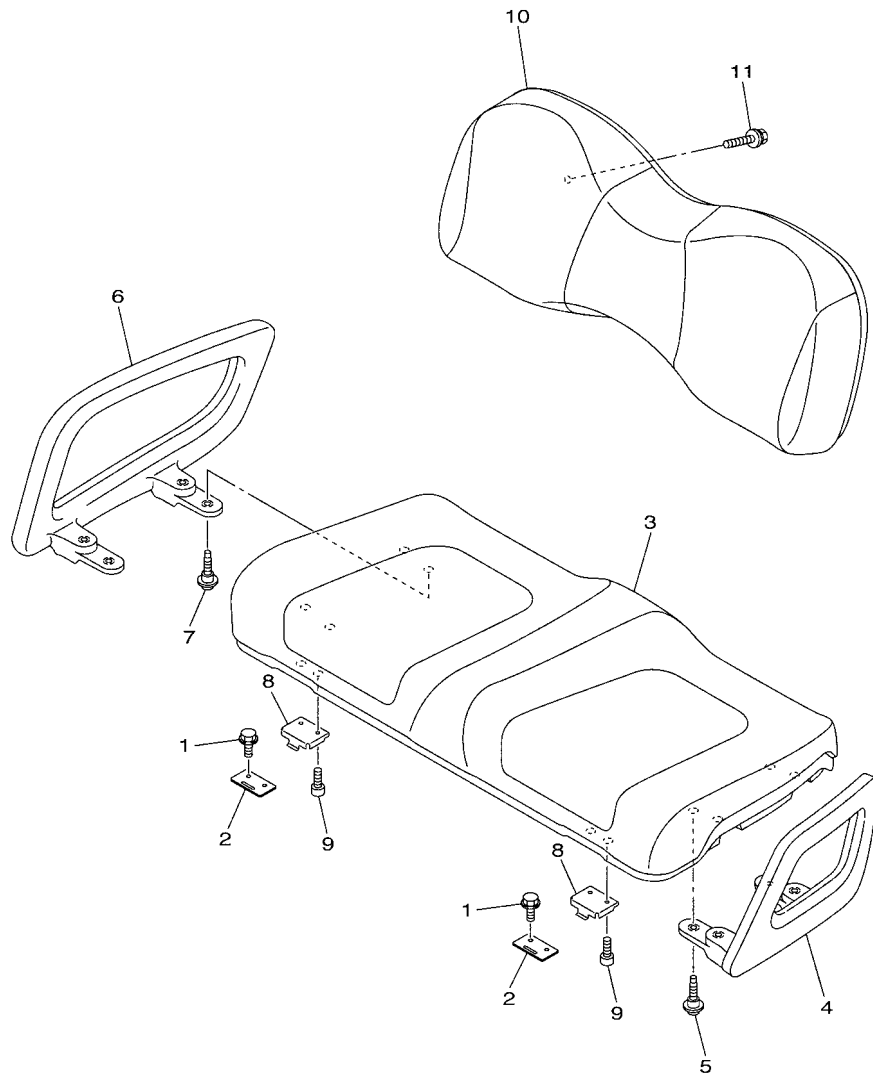
REF. NO.	PART NO.	DESCRIPTION	J0C2	REMARKS
1	J0B-K8271-00	SERVICE LID, PEDAL	1	
2	J0B-K818A-00	PROTECTOR, SIDE PLATE	1	
3	90269-09003	RIVET	3	
4	90269-06804	RIVET	1	
5	J0B-K818B-00	PROTECTOR, SIDE PLATE 2	1	
6	90269-09003	RIVET	3	
7	90269-06804	RIVET	1	
8	J0B-K8191-00	PANEL, REAR FENDER 1	1	
9	90269-06804	RIVET	5	
10	J0B-K8192-00	PANEL, REAR FENDER 2	1	
11	90269-06804	RIVET	5	

**FIG. 14 CARRIER**



J0B1110-S280

REF. NO.	PART NO.	DESCRIPTION	J0C2				REMARKS
1	J0B-K8423-00	SUPPORT, SEAT BACK	1				
2	90109-08002	BOLT	4				
3	JW1-K8340-00	LUGGAGE RACK ASSY., REAR	1				
4	92017-06040	BOLT, BUTTON HEAD	4				
5	J0B-K7389-00	WASHER	4				
6	90176-06008	NUT, CROWN	4				
7	JF2-K8356-00	PAD, BAG SUPPORT	1				
8	JN6-K8355-20	BAND	1				
9	JW1-K834G-00	HOLDER, RAKE SAND	1				
10	9708R-06020	BOLT	1				
11	90185-06836	NUT, SELF-LOCKING	1				
12	JN6-K8380-00	LOCK ASSY	2				
13	90159-06845	SCREW, WITH WASHER	4				
14	9299R-06200	WASHER	4				

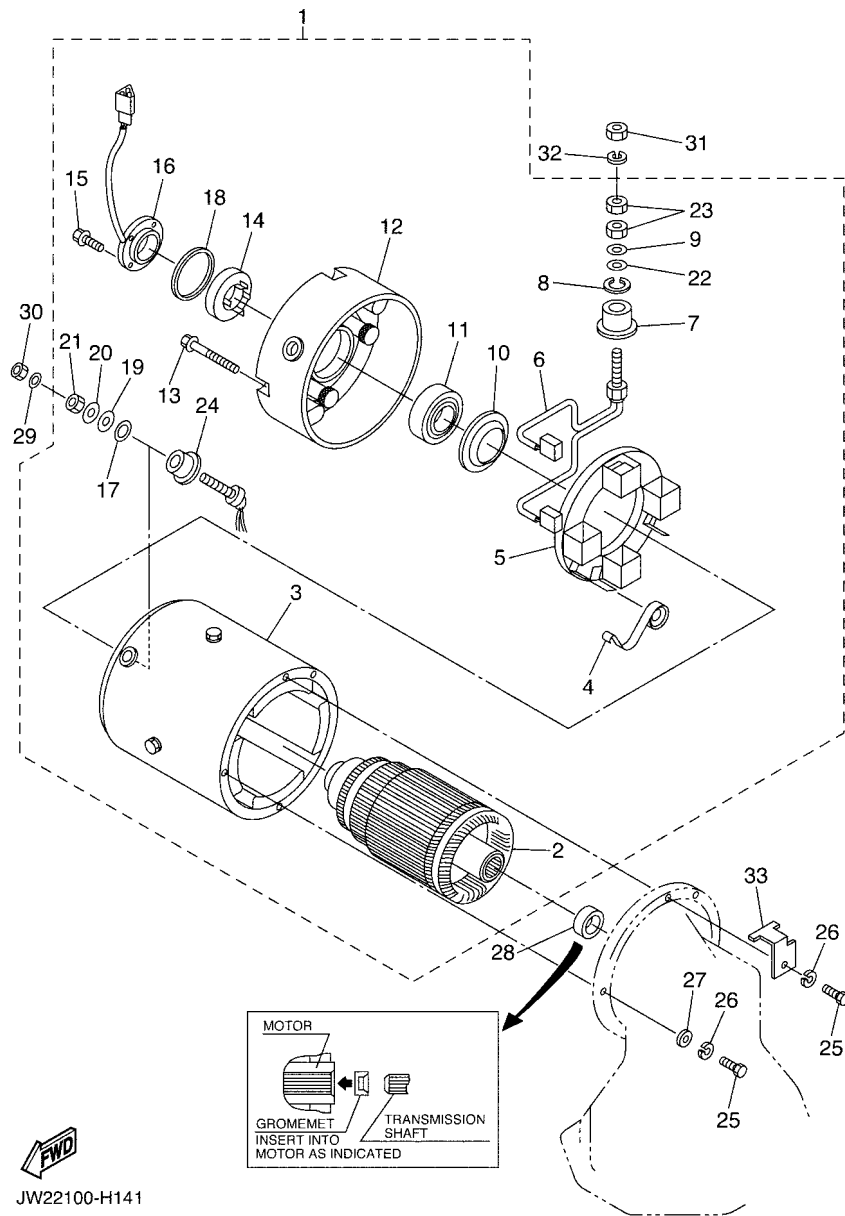


J0B1110-S290

**FIG. 15 SEAT**

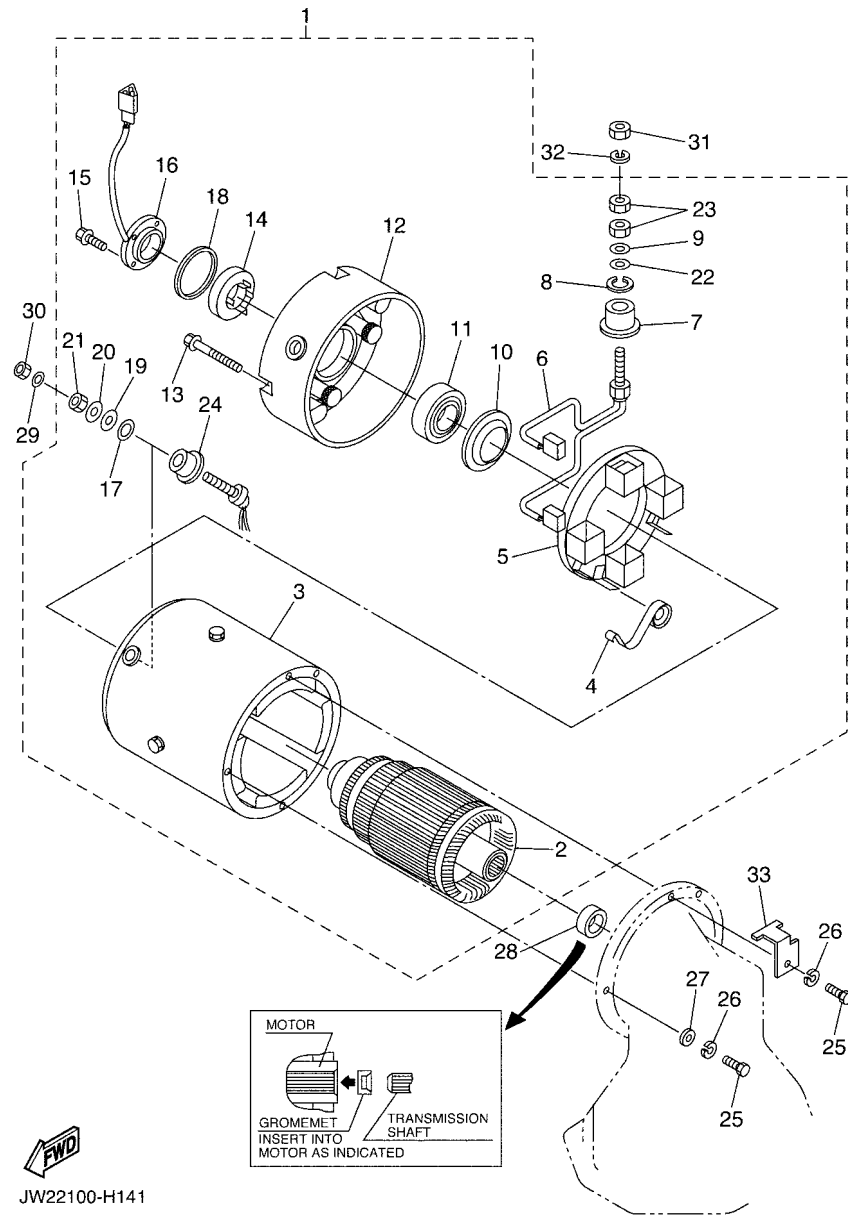
REF. NO.	PART NO.	DESCRIPTION	J0C2				REMARKS
1	JW9-H1674-00	BOLT	4				
2	JW1-K8427-00	HINGE, SEAT 2	2				
3	J0A-K8401-00	SEAT SUB-ASSY,CUSHION	1				
4	J0B-K8361-00	ARM REST 1	1				
5	J0B-F1738-00	BOLT	4				
6	J0B-K8362-00	ARM REST 2	1				
7	J0B-F1738-00	BOLT	4				
8	J0B-K8426-01	HINGE, SEAT 1	2				
9	90110-06125	BOLT, HEXAGON SOCKET HEAD	4				
10	JW1-K8402-10	SEAT SUB ASSY, BACK	1				
11	90119-06808	BOLT, WITH WASHER	4				

FIG. 16 ELECTRIC MOTOR



REF. NO.	PART NO.	DESCRIPTION	JQC2				REMARKS
1	JU2-H1890-23	MOTOR ASSY	1				
2	JU2-H1850-23	.ARMATURE ASSY	1				
3	JU2-H1160-20	.FIELD COIL ASSY	1				
4	JU2-H1617-20	.SPRING, BRUSH	4				
5	JU2-H1840-20	.BRUSH HOLDER ASSY	1				
6	JU2-H1801-20	.BRUSH SET	2				
7	JU2-H182G-20	.BUSH, TERMINAL	2				
8	JU2-H1843-20	.WASHER 1	2				
9	JU2-H181L-20	.WASHER, PLAIN	2				
10	JU2-H1856-20	.RETAINER	1				
11	JU2-H185B-20	.BEARING 1	1				
12	JU2-H183J-20	.BRACKET, FRONT	1				
13	JU2-H1828-20	.SCREW 2	4				
14	JU2-H181K-20	.MAGNET	1				
15	JU2-H2113-20	.SCREW	4				
16	JU2-H1670-22	.PICK-UP ASSY	1				
17	JU2-H272L-20	.INSULATOR, 1	2				
18	JU2-H5722-20	.INSULATOR	1				
19	JU2-H2517-20	.WASHER, SPECIAL	2				
20	JU2-H332D-20	.WASHER, SPECIAL 2	2				
21	JU2-H191B-20	.NUT	4				
22	JU2-H1824-20	.WASHER 2	2				
23	JU2-H182K-20	.NUT	4				
24	JU2-H182H-20	.BUSH, TERMINAL 2	2				
25	90101-069U0	BOLT	3				
26	90215-06811	WASHER, LOCK	3				
27	90201-068E2	WASHER, PLATE	2				

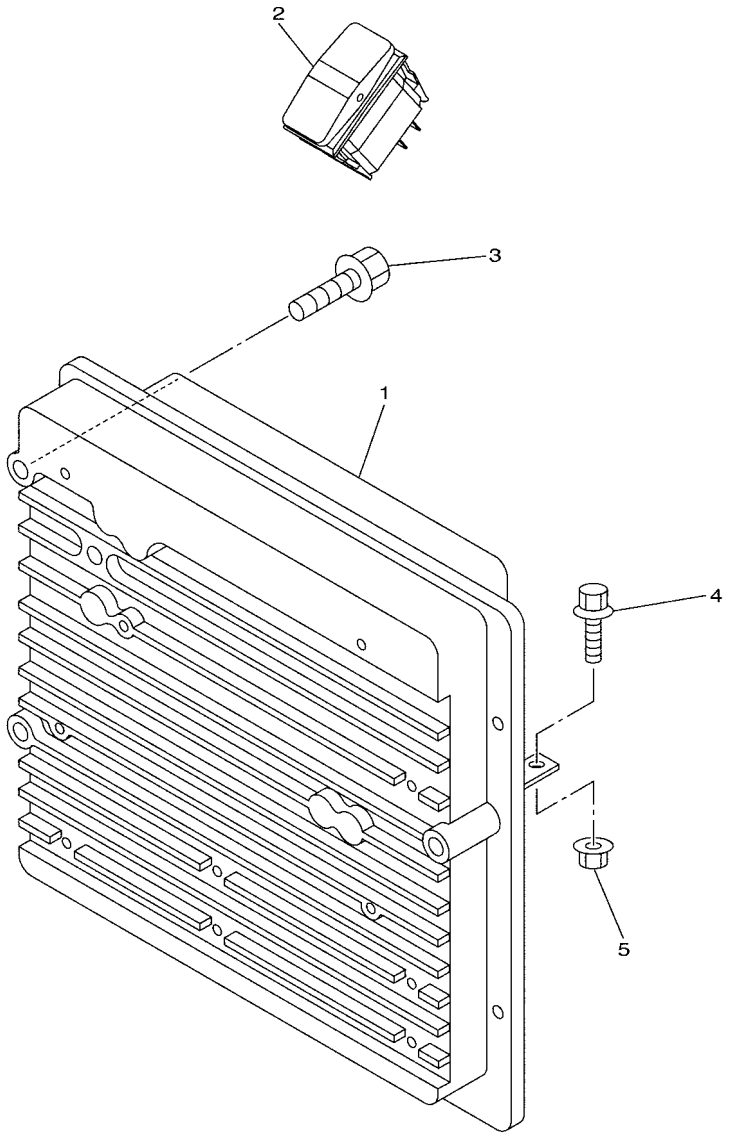
**FIG. 16 ELECTRIC MOTOR**



REF. NO.	PART NO.	DESCRIPTION	JOC2				REMARKS
28	JW9-H1829-00	GROMMET	1				
29	JU2-H185A-20	WASHER, PLATE	2				
30	JU2-H182A-20	NUT	2				
31	JU2-H1872-20	NUT, SPECIAL	2				
32	JU2-H1835-20	WASHER	2				
33	JU2-H218E-01	RELIEF, STRAIN 1	1				

JW22100-H141

**FIG. 17 CONTROLLER 1**



REF. NO.	PART NO.	DESCRIPTION	JOC2				REMARKS
1	JW2-H6510-20	MOTOR CONTROL UNIT ASSY	1				
2	JW2-H2727-00	SWITCH	1				
3	JW9-H1674-00	BOLT	3				
4	95822-06016	BOLT, FLANGE	3				
5	95602-06200	NUT, SELF-LOCKING	3				

**FWD**  
 JW23110-J150

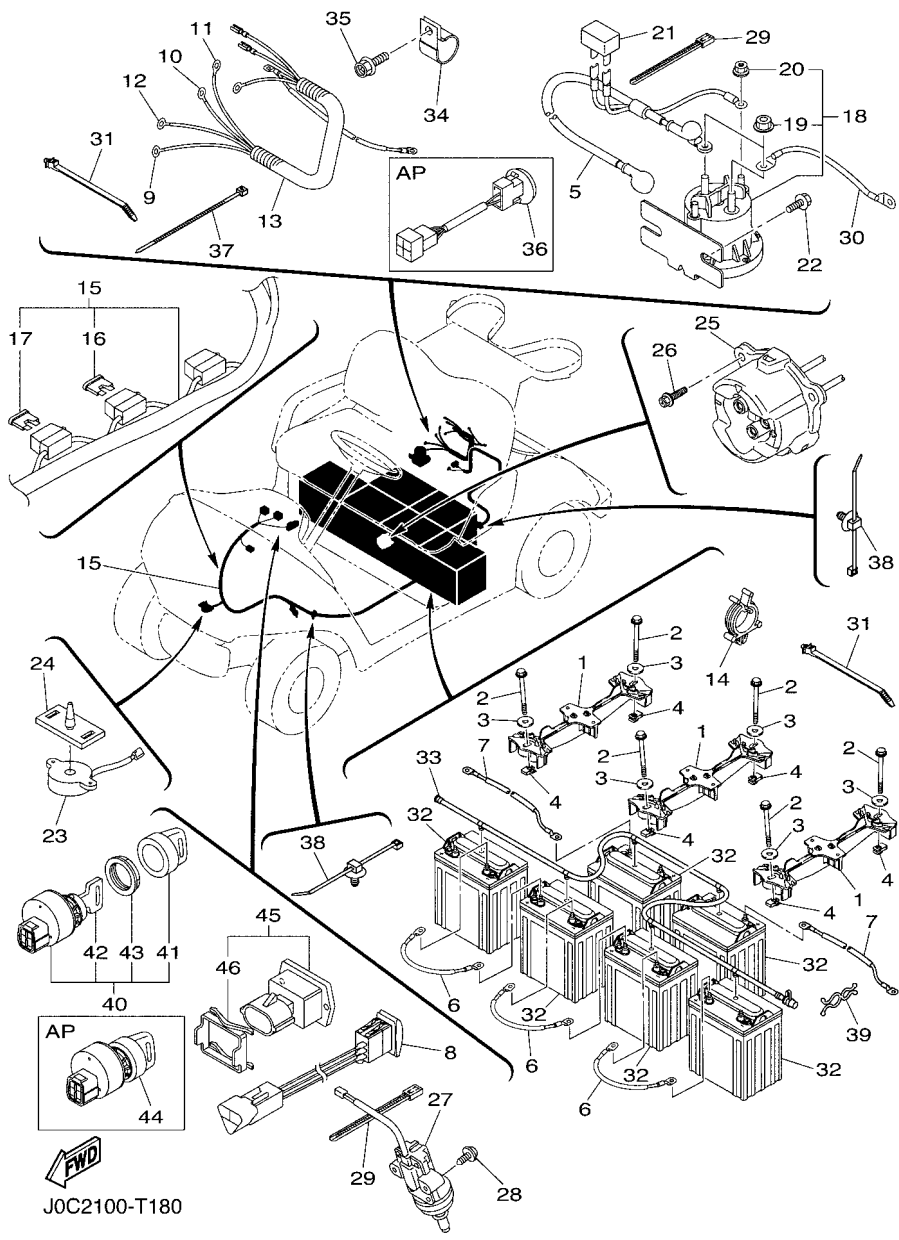


FIG. 18 ELECTRICAL 1

REF. NO.	PART NO.	DESCRIPTION	J0C2	REMARKS
1	JW9-H2136-00	PLATE, BATTERY FITTING	3	
2	JW9-H1892-00	BOLT, SPECIAL	6	
3	90201-08310	WASHER, PLATE	6	
4	JW9-K811K-00	NUT, TRIM FITTING	6	
5	JW9-H2115-20	WIRE, PLUS LEAD	1	
6	JW9-H2127-00	WIRE, LEAD 2	3	
7	JW9-H2149-00	WIRE, LEAD 3	2	
8	JU2-H2917-00	SWITCH	1	
9	JU2-H2521-20	WIRE, LEAD	1	(S1)
10	JU2-H2531-20	WIRE, LEAD	1	(S2)
11	JU2-H6171-20	WIRE, LEAD 1	1	(A1)
12	JW9-H6172-00	WIRE, LEAD 2	1	(A2)
13	JU2-H7196-20	TUBE 1	1	
14	90464-25826	CLAMP	2	
15	J0C-H2590-01	WIRE HARNESS ASSY	1	UR FOR CAN
	J0C-H2590-11	WIRE HARNESS ASSY	1	UR EXCEPT FOR CAN
16	J0C-H2151-00	.FUSE (5A)	1	
17	JR1-H2151-00	.FUSE (3A)	1	
18	JW9-H1950-20	RELAY ASSY	1	
19	90179-05807	.NUT	2	
20	90179-08824	.NUT	2	
21	JW9-85371-00	RESISTOR COMP.	1	
22	90105-06831	BOLT, FLANGE	2	
23	JR1-H3383-02	BUZZER	1	
24	JN6-H3386-01	STAY, BUZZER	1	
25	JW9-H6181-00	RECEPTACLE	1	
26	JW1-F3394-00	BOLT, SPECIAL	3	

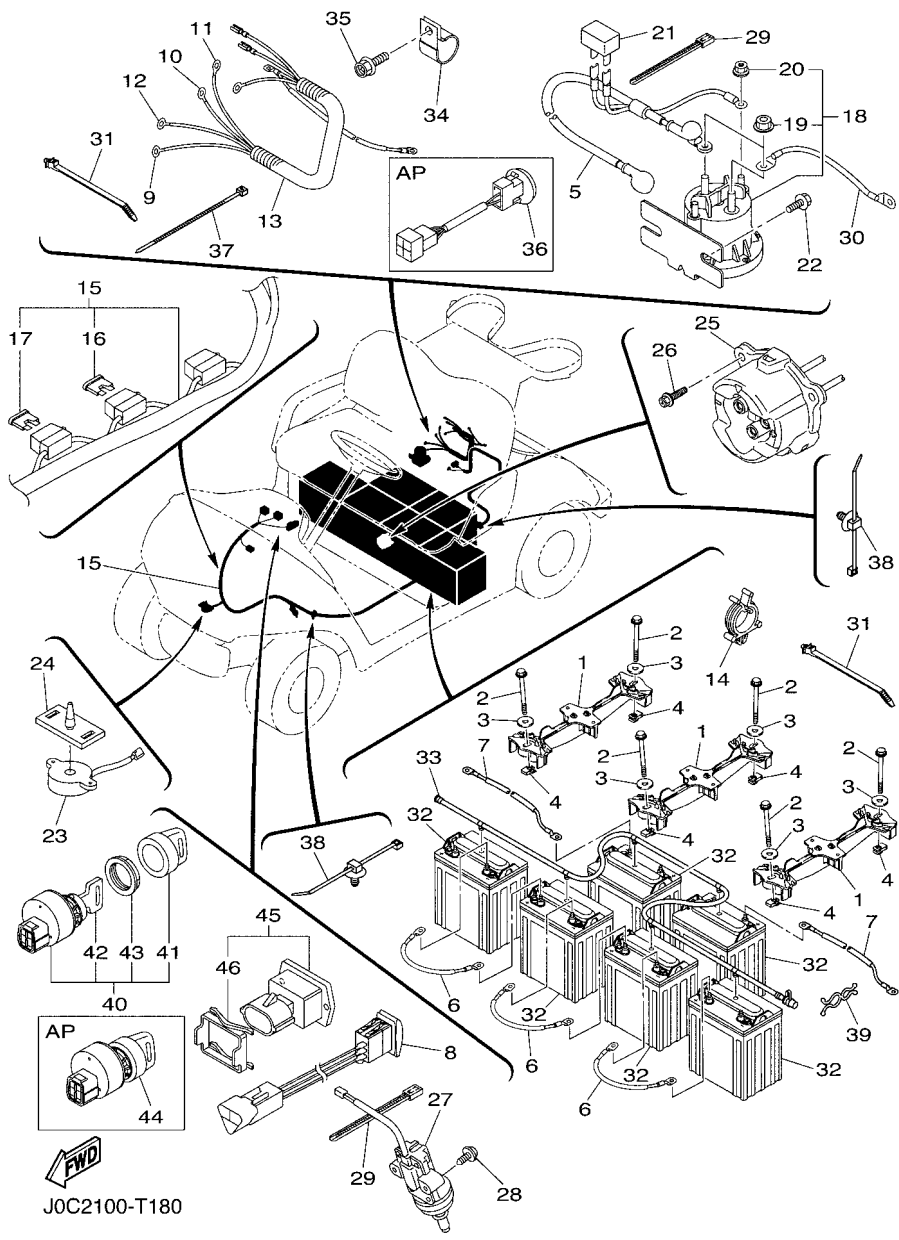
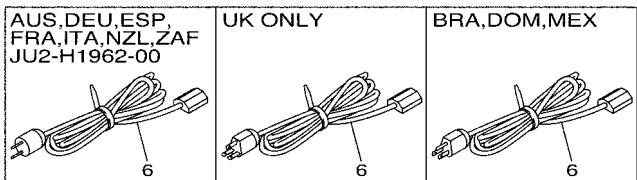
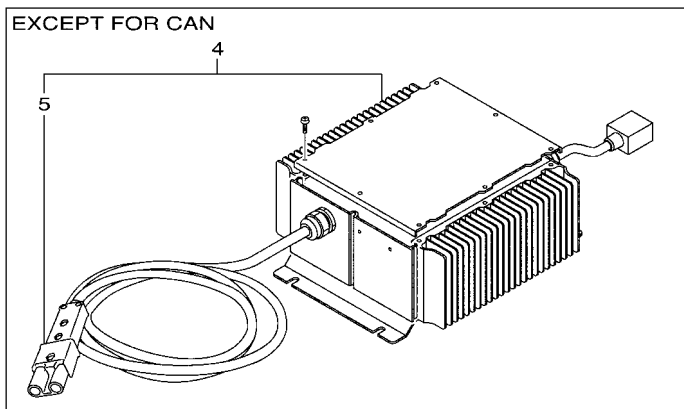
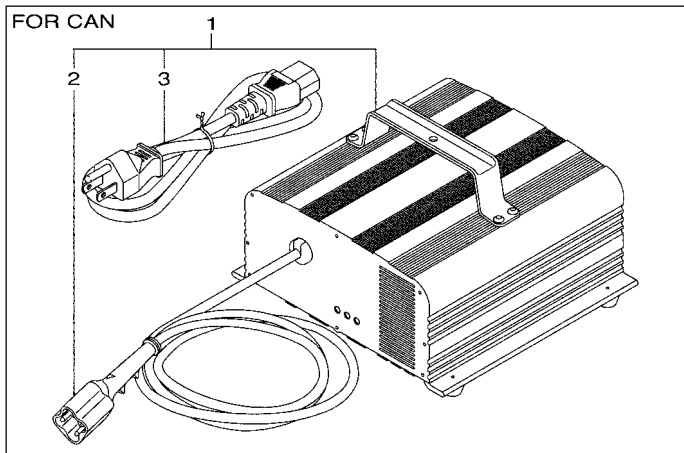


FIG. 18 ELECTRICAL 1

REF. NO.	PART NO.	DESCRIPTION	JOC2	REMARKS
27	JF7-82817-22	SWITCH	1	
28	97602-05225	SCREW, PAN HEAD WITH WASHER	2	
29	90464-40825	CLAMP	3	
30	JW2-H6527-00	WIRE 7	1	
31	90464-20005	CLAMP	6	
32	*	BATTERY ASSY (8V, GC8)	6	LM
33	JW9-H210G-00	BATTERY WATERING SYSTEM ASSY.	1	
34	90461-14108	CLAMP	1	
35	90105-08867	BOLT, FLANGE	1	
36	JU2-HA2F0-00	TRANSMITTER UNIT	1	AP
37	90464-48800	CLAMP	1	
38	1NS-F1338-00	CLAMP	2	
39	90464-14134	CLAMP	1	
40	JW1-H2510-00	MAIN SWITCH ASSY	1	STD
41	5UG-H2579-00	.CAP, KEY	1	
42	JU2-H2511-00	.KEY, MAIN SWITCH	2	
43	JU6-H2569-00	.NUT, MAIN SWITCH	1	
44	JU2-H2510-20	MAIN SWITCH ASSY	1	AP RANDOMKEY
45	JW2-H351B-00	GAUGE, BATTERY	1	EXCEPT FOR CAN
46	JW1-H1128-00	.CLAMP	1	EXCEPT FOR CAN



**FIG. 19 BATTERY CHARGER**



REF. NO.	PART NO.	DESCRIPTION	JOC2		REMARKS
1	JW9-82107-03	CHARGER, BATTERY	1		FOR CAN
2	JW9-82174-00	.DC CORD ASSY	1		FOR CAN
3	JW9-81962-00	.AC CORD COMP.	1		FOR CAN
4	JW2-H2107-13	CHARGER, BATTERY	1		EXCEPT FOR CAN
5	JR1-H235A-00	.DC PLUG SET	1		EXCEPT FOR CAN
6	JU2-H1962-00	CORD COMP. (220V)	1		UR
	JU2-H1962-10	CORD COMP. (240V)	1		UR UK
	JU2-H1962-20	CORD COMP. (100V)	1		UR BRA,DOM,MEX



JW95100-N170

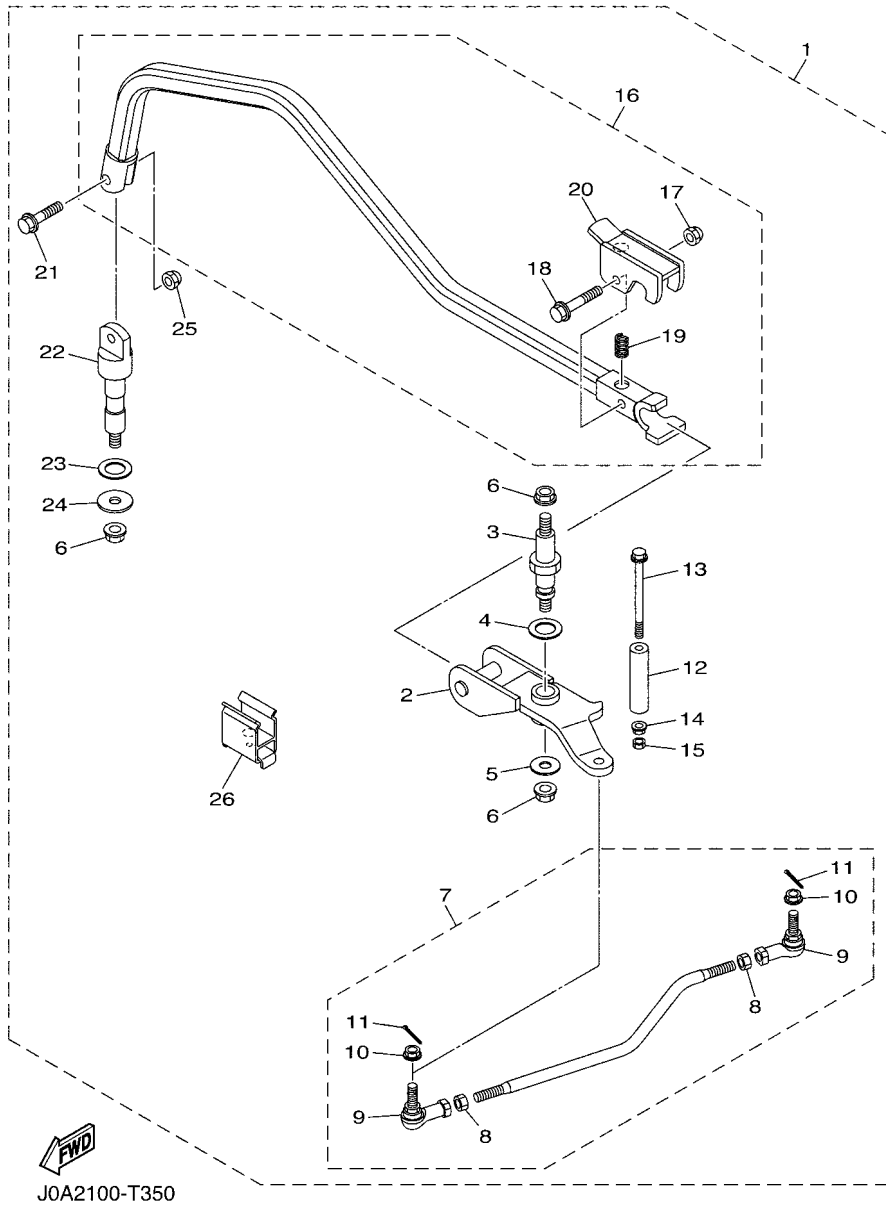
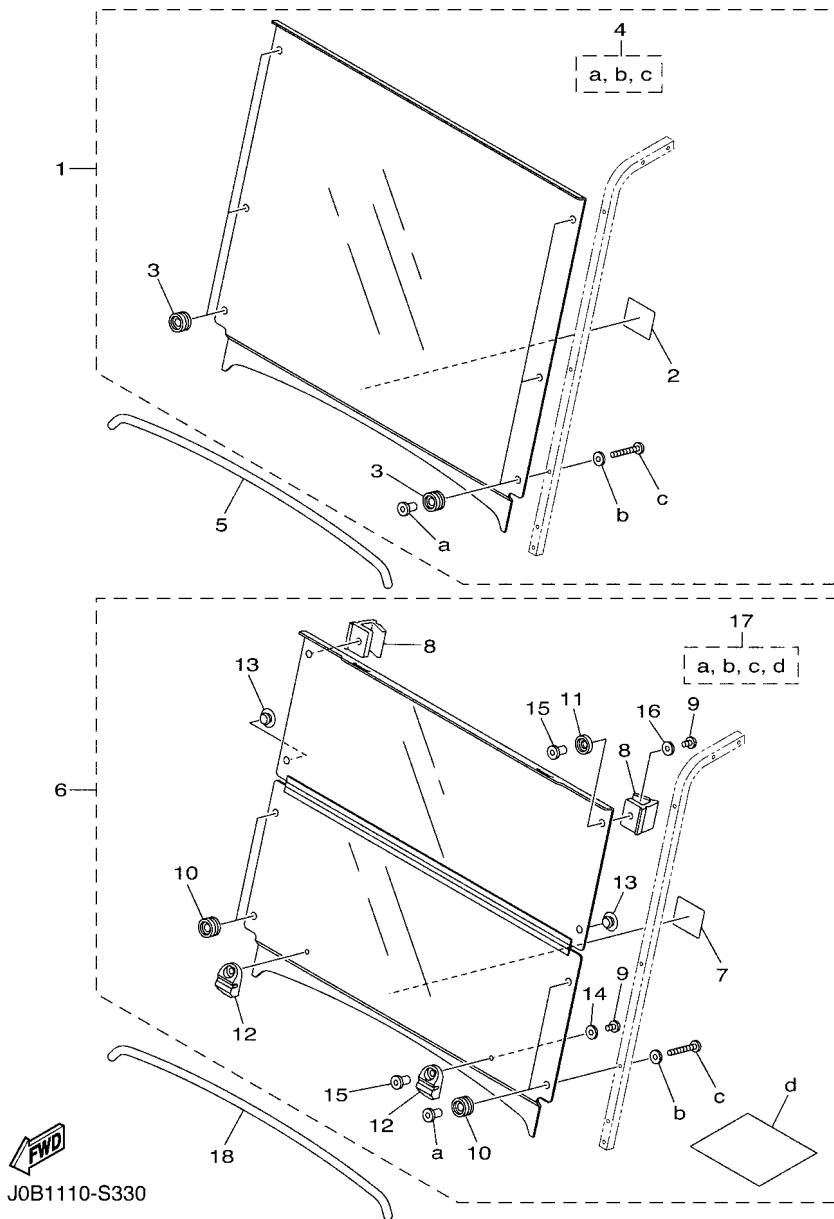


FIG. 20 ALTERNATE FOR CHASSIS

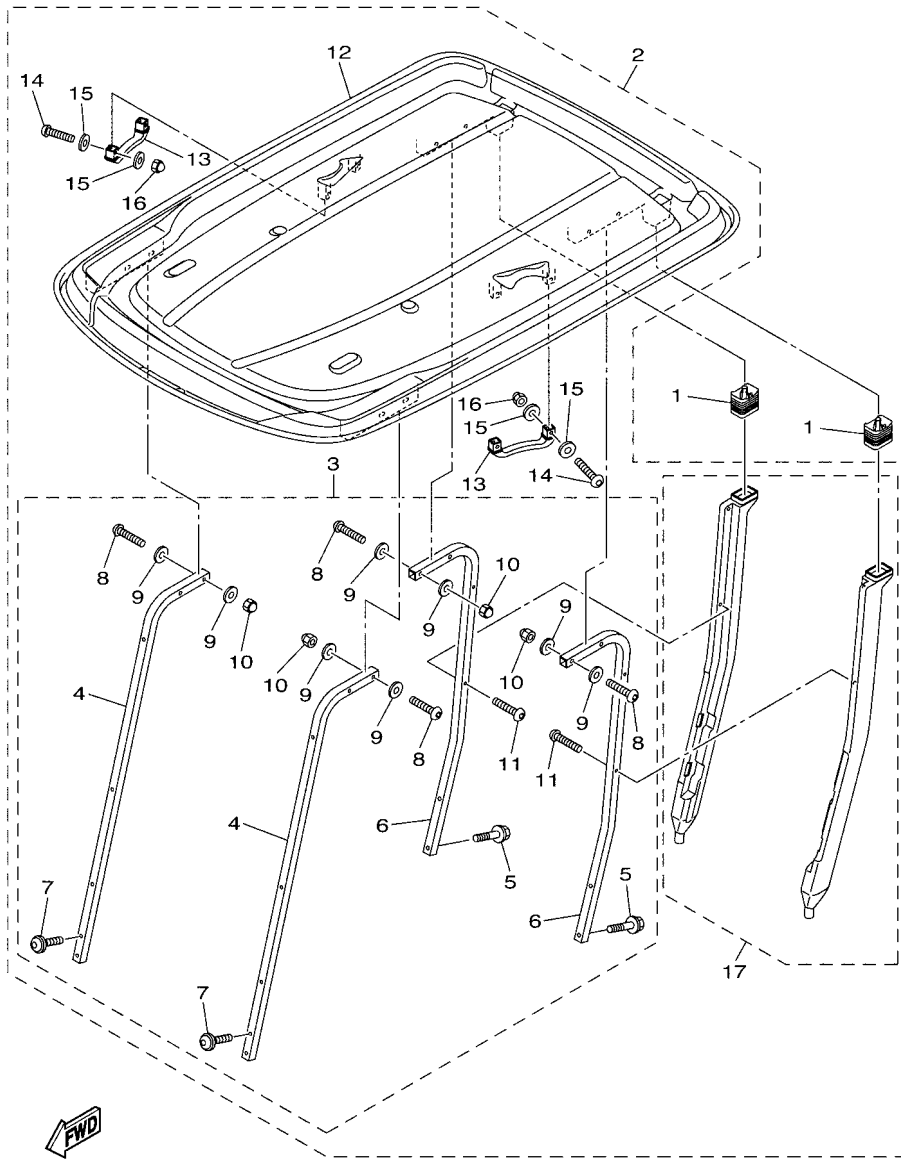
REF. NO.	PART NO.	DESCRIPTION	JOC2				REMARKS
1	J0B-F722B-00	BAR, TOW	1				
2	J0B-F389G-00	.ARM, PIVOT	1				
3	J0B-F3849-00	.SHAFT 1	1				
4	90201-208S8	.WASHER, PLATE	1				
5	J0B-F3392-00	.WASHER, SPECIAL	1				
6	95602-12200	.NUT, SELF-LOCKING	3				
7	J0B-F3880-00	.TIE ROD ASSEMBLY 3	1				
8	95302-10600	..NUT, HEXAGON	2				
9	J0B-F3841-00	..JOINT, UNIVERSAL 1	2				
10	95602-12200	..NUT, SELF-LOCKING	2				
11	91402-25020	..PIN, COTTER	2				
12	J0B-F3432-00	.STOPPER, STEERING 1	1				
13	90105-088A9	.BOLT, FLANGE	1				
14	95602-08200	.NUT, U FLANGE	1				
15	95602-08100	.NUT, U	1				
16	J0B-F389A-00	.BAR, DRAW	1				
17	J0B-F4681-00	..NUT, CAP	1				
18	95812-10050	..BOLT, FLANGE	1				
19	J0B-F178D-00	..SPRING, HOOK	1				
20	J0B-F381J-00	..BAR, HANDLE	1				
21	95802-10035	.BOLT, FLANGE	1				
22	J0B-F2141-00	.SHAFT, PIVOT	1				
23	J0B-F3418-00	.WASHER, SPECIAL	1				
24	90201-128S4	.WASHER, PLATE	1				
25	J0B-F4681-00	.NUT, CAP	1				
26	J0B-F5522-00	.HOLDER	1				

FIG. 21 ALTERNATE FOR WINDSHIELD



J0B1110-S330

REF. NO.	PART NO.	DESCRIPTION	JOC2				REMARKS
1	J0B-K7200-00	WINDSHIELD ASSY	1				UR CLEAR
	J0B-K7200-10	WINDSHIELD ASSY	1				UR SMOKE
2	J0B-K7458-00	.LABEL, WARNING	1				
3	J0B-K7237-00	.GROMMET	6				
4	J0B-K7240-00	.WIND SHIELD HARDWARE KIT 1	1				
5	J0B-K7213-00	TRIM, UPPER	1				
6	J0B-K7200-20	WINDSHIELD ASSY	1				UR CLEAR
	J0B-K7200-30	WINDSHIELD ASSY	1				UR SMOKE
7	J0B-K7458-00	.LABEL, WARNING	1				
8	J0B-K7173-20	.LEVER, LATCH 1	2				
9	J0B-K7258-00	.SCREW, 2	4				
10	J0B-K7237-00	.GROMMET	4				
11	J0B-K7247-00	.GROMMET, W/S 2	2				
12	J0B-K7257-00	.GROMMET, W/S 3	2				
13	J0B-K7238-00	.DAMPER	2				
14	J0B-K7218-00	.WASHER 1	2				
15	J0B-K7217-00	.NUT, WIND SHIELD	4				
16	J0B-K7219-00	.WASHER 2	2				
17	J0B-K7240-20	.WIND SHIELD HARDWARE KIT 1	1				
18	J0B-K7213-00	TRIM, UPPER	1				



J0A2100-T370

FIG. 22 ALTERNATE FOR SUN ROOF

REF. NO.	PART NO.	DESCRIPTION	JOC2	REMARKS
1	JW1-F414G-10	SEAL	2	
2	J0B-K84A0-00	SUN TOP KIT	1	UR AP TAN
	J0B-K84A0-10	SUN TOP KIT	1	UR AP BLACK
3	J0B-K84A2-00	.HARDWARE KIT, SUN TOP	1	
4	J0B-K8312-00	..SUPPORT, SUN ROOF 1	2	
5	JW1-K8388-00	..BOLT, ROOF 1	4	
6	JW1-K8313-01	..SUPPORT, SUN ROOF 2	2	
7	J0B-K8388-00	..BOLT, ROOF 1	4	
8	JU0-K8388-00	..BOLT, ROOF 1	8	
9	JW1-F1549-01	..WASHER, FENDER MOLD	16	
10	JU0-K8398-00	..NUT, ROOF 1	8	
11	JW1-K7387-00	..SCREW	4	
12	JW1-K8314-10	..COVER, SUN ROOF	1	UR TAN
	JW1-K8314-21	..COVER, SUN ROOF	1	UR BLACK
13	JW1-K8214-00	..GRIP, HAND	2	
14	JU0-K8388-00	..BOLT, ROOF 1	4	
15	JW1-F1549-01	..WASHER, FENDER MOLD	8	
16	JU0-K8398-00	..NUT, ROOF 1	4	
17	J0B-F417A-00	..DRAIN TUBE ASSY	1	

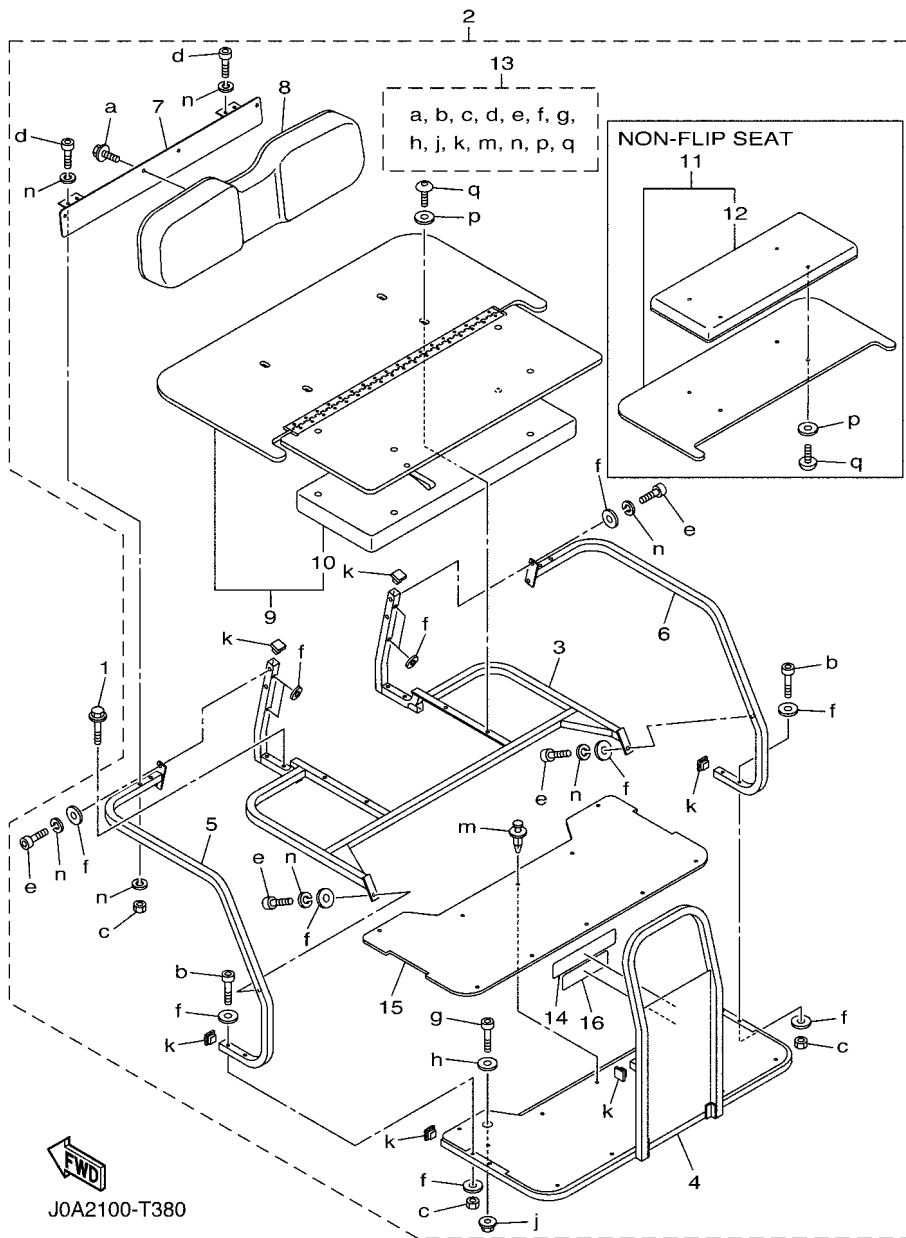


FIG. 23 ALTERNATE FOR SEAT

REF. NO.	PART NO.	DESCRIPTION	J0C2	REMARKS
1	90109-08002	BOLT	4	
2	J0B-K8476-00	4 PASSENGER SEAT COMP.	1	UR TAN FLIP
	J0B-K8410-00	SEAT ASSY	1	UR TAN NON-FLIP
	J0B-K8476-10	4 PASSENGER SEAT COMP.	1	UR BLACK FLIP
	J0B-K8410-10	SEAT ASSY	1	UR BLACK NON-FLIP
3	J0B-K8460-00	.SEAT FRAME COMP.	1	
4	J0B-K8477-00	.FLOOR ASSEMBLY	1	
5	J0B-K8473-00	.HANDRAIL ASSEMBLY (LH)	1	
6	J0B-K8474-00	.HANDRAIL ASSEMBLY (RH)	1	
7	J0B-K8432-00	.BRACKET, SEAT SUPPORT 2	1	
8	J0B-K8402-00	.SEAT SUB ASSY, BACK	1	
9	J0B-K8480-00	.SEAT BOTTOM COMPLETE 1	1	UR TAN
	J0B-K8480-10	.SEAT BOTTOM COMPLETE 1	1	UR BLACK
10	J0B-K8406-00	.REAR SEAT SUB-ASSY, CUSHION	1	UR TAN
	J0B-K8406-10	.REAR SEAT SUB-ASSY, CUSHION	1	UR BLACK
11	J0B-K8490-00	.SEAT BOTTOM COMP. ,2	1	UR TAN
	J0B-K8490-10	.SEAT BOTTOM COMP. ,2	1	UR BLACK
12	J0B-K8406-00	.REAR SEAT SUB-ASSY, CUSHION	1	UR TAN
	J0B-K8406-10	.REAR SEAT SUB-ASSY, CUSHION	1	UR BLACK
13	J0B-F47E2-00	.HARDWARE KIT, TANDEM SEAT	1	UR FLIP SEAT
	J0B-F47E2-10	.HARDWARE KIT, TANDEM SEAT	1	UR NON-FLIP SEAT
14	J0B-K8483-00	.LABEL WARNING	1	
15	J0B-K8466-00	.MAT, RUBBER	1	
16	J0B-F1696-00	.LABEL, CAUTION	1	

NUMERICAL INDEX

PART NO.	REF. NO.	PART NO.	REF. NO.	PART NO.	REF. NO.	PART NO.	REF. NO.	PART NO.	REF. NO.	PART NO.	REF. NO.
401-22128-01	3 - 16	J0C-F3350-00	3 - 14	J0B-F4681-00	20 - 17	JW8-F7318-00	6 - 20	JW9-H1674-00	17 - 3	J0C-H2590-11	18 - 15
2NL-23448-00	3 - 9	J0C-F3390-00	3 - 19		20 - 25	JW8-F7322-00	6 - 15	JU2-H1801-20	16 - 6	JW2-H2727-00	17 - 2
2NL-23517-00	3 - 11	J0B-F3392-00	20 - 5	J0B-F4681-00	23 - 13	JOC-F7411-01	2 - 5	JU2-H181K-20	16 - 14	JU2-H272L-20	16 - 17
2HR-23526-00	3 - 3	JW1-F3394-00	18 - 26	J0B-F47E2-10	23 - 13	JW8-F7416-00	6 - 8	JU2-H181L-20	16 - 9	JU2-H2917-00	18 - 8
JW8-23841-01	4 - 27	JW1-F3400-00	4 - 10	JW1-F5100-01	9 - 1	JW8-F7426-01	6 - 17	JU2-H1824-20	16 - 22	JU2-H332D-20	16 - 20
J38-27204-00	7 - 15	J0B-F3418-00	20 - 23	JW8-F5103-00	3 - 21	JW8-F7434-00	6 - 39	JR1-H1828-20	16 - 13	JR1-H3383-02	18 - 23
J38-27205-00	7 - 4	J0B-F3432-00	20 - 12	JW8-F5118-00	8 - 38	JW8-F7435-00	6 - 56	JW9-H1829-00	16 - 28	JN6-H3386-01	18 - 24
J55-27260-00	7 - 9	J0B-F3447-00	12 - 2	JN6-F5118-01	3 - 29	JW8-F7438-00	6 - 38	JU2-H182A-20	16 - 30	JW2-H351B-00	18 - 45
J55-27270-00	7 - 20		12 - 5	JW8-F5415-00	6 - 25	JW9-F7445-31	6 - 33	JU2-H182G-20	16 - 7	JU2-H5722-20	16 - 18
J10-27282-00	7 - 6		12 - 13	J0B-F5522-00	20 - 26	JW8-F7814-21	6 - 3	JU2-H182H-20	16 - 24	JW9-H5885-00	6 - 52
	7 - 17	5UG-F3489-00	4 - 20	JW9-F5666-00	6 - 12		6 - 43	JU2-H182K-20	16 - 23	JU2-H6171-20	18 - 11
JW9-81962-00	19 - 3	JU0-F3511-20	3 - 4	JW9-F5671-00	6 - 5	JW8-F7825-01	6 - 27	JU2-H1835-20	16 - 32	JW9-H6172-00	18 - 12
JW9-82107-03	19 - 1	JW1-F3512-00	3 - 5	JW9-F5672-00	6 - 4	JW9-F7850-31	6 - 1	JU2-H183J-20	16 - 12	JW9-H6181-00	18 - 25
JW9-82174-00	19 - 2	JU0-F3521-20	3 - 12	JW9-F5673-00	6 - 45	JW9-F7853-00	6 - 35	JU2-H1840-20	16 - 5	JW2-H6510-20	17 - 1
JF7-82817-22	18 - 27	5UG-F3527-00	4 - 21	JW8-F5681-10	5 - 5	JW9-F7871-10	6 - 36	JU2-H1843-20	16 - 8	JW2-H6527-00	18 - 30
JW9-85371-00	18 - 21	J0B-F3570-10	3 - 1	JN6-F5685-01	5 - 6	JW9-F7872-20	6 - 37	JU2-H1850-23	16 - 2	JU2-H7196-20	18 - 13
J0B-F125J-00	2 - 19	JW1-F3811-03	4 - 1	JW9-F5827-00	6 - 53	JW8-F815H-01	6 - 42	JU2-H1856-20	16 - 10	JU2-HA2F0-00	18 - 36
1NS-F1338-00	18 - 38	JW1-F3812-00	4 - 13	JW9-F5827-10	6 - 53	JW8-F8319-00	6 - 29	JU2-H185A-20	16 - 29	J0B-K7115-00	4 - 37
JW1-F1549-01	22 - 9	J0B-F381J-00	20 - 20	JW8-F6314-00	6 - 21	JW8-F8323-00	6 - 24	JU2-H185B-20	16 - 11	J0B-K7173-20	21 - 8
	22 - 15	JW1-F3822-01	4 - 29	JW9-F632G-00	6 - 54	JW8-F8331-00	6 - 47	JU2-H1872-20	16 - 31	J0B-K7200-00	21 - 1
J0B-F1696-00	23 - 16	JU0-F3828-10	4 - 4	JW9-F6351-10	5 - 1	JW8-F8363-00	6 - 7	JU2-H1890-23	16 - 1	J0B-K7200-10	21 - 1
J0B-F1738-00	2 - 6	1P0-F3833-00	4 - 26	JW8-F639L-00	6 - 22	JW8-G2535-00	8 - 34	JW9-H1892-00	18 - 2	J0B-K7200-20	21 - 6
	12 - 9	JW1-F3837-00	4 - 22	JW8-F639N-00	6 - 9	JW8-G2536-00	8 - 35	JU2-H191B-20	16 - 21	J0B-K7200-30	21 - 6
	12 - 14	J0A-F3838-00	4 - 6	JW8-F7113-00	6 - 11	JW8-G2541-00	8 - 39	JW9-H1950-20	18 - 18	J0B-K7213-00	21 - 5
	15 - 5	J0B-F3841-00	20 - 9	JW8-F7117-00	6 - 6	JW8-G2756-00	8 - 36	JU2-H1962-00	19 - 6		21 - 18
	15 - 7	5UG-F3844-00	4 - 19	JW8-F7118-00	6 - 41	JH7-G3396-01	8 - 9	JU2-H1962-10	19 - 6	J0B-K7217-00	21 - 15
JW1-F1738-00	2 - 8	J0B-F3849-00	20 - 3	JW8-F7119-00	6 - 28	JW8-G4178-00	8 - 32	JU2-H1962-20	19 - 6	J0B-K7218-00	21 - 14
	2 - 11	JU0-F3857-11	4 - 3	JW8-F7121-00	6 - 13	JW8-G5244-00	8 - 33	JW2-H2107-13	19 - 4	J0B-K7219-00	21 - 16
J0B-F178D-00	20 - 19		4 - 5	JW9-F7200-21	6 - 2	JW8-G5378-00	8 - 22	JW9-H210G-00	18 - 33	J0B-K7237-00	21 - 3
J0C-F2110-00	1 - 1	JW1-F3866-00	4 - 24	JW8-F7213-20	6 - 34	JW9-G6136-00	8 - 8	JU2-H2113-20	16 - 15		21 - 10
JN6-F2123-10	1 - 2	JW1-F387A-00	4 - 11	JW8-F7217-00	6 - 32	JOC-G6300-00	7 - 1	JW9-H2115-20	18 - 5	J0B-K7238-00	21 - 13
JN6-F2124-10	1 - 6	JW1-F387E-00	4 - 14	JW8-F7218-00	6 - 10		8 - 1	JW9-H2127-00	18 - 6	J0B-K7240-00	21 - 4
J0B-F2127-00	2 - 14	5UG-F387F-00	4 - 17	JW9-F7221-00	6 - 14	JW9-G6312-00	8 - 19	JW9-H2136-00	18 - 1	J0B-K7240-20	21 - 17
J0B-F2141-00	20 - 22	5UG-F387G-00	4 - 15	JW9-F7228-00	6 - 23	JW9-G631A-00	8 - 18	JW9-H2149-00	18 - 7	J0B-K7247-00	21 - 11
JW1-F217G-10	1 - 10	5UG-F387J-00	4 - 18	J0B-F722B-00	20 - 1	JW9-G6321-00	8 - 3	JOC-H2151-00	18 - 16	J0B-K7257-00	21 - 12
JW9-F2198-10	2 - 10	5UG-F387K-00	4 - 16	JW9-F7231-10	6 - 18	JW9-G6350-00	8 - 11	JR1-H2151-00	18 - 17	J0B-K7258-00	21 - 9
JOC-F2210-00	1 - 14	J0B-F3880-00	20 - 7	JW9-F7232-00	6 - 19	JW9-G6410-00	8 - 15	JU2-H218E-01	16 - 33	JW7-K7329-00	12 - 8
JW9-F2417-00	2 - 9	JW1-F3894-00	4 - 25	JW9-F7245-10	6 - 30	JW9-G6421-00	8 - 13	JR1-H235A-00	19 - 5	J0B-K7363-00	4 - 36
J0A-F2501-00	2 - 1	J0B-F389A-00	20 - 16	JW9-F7246-20	6 - 46	JN3-G6432-00	8 - 20	J0B-H2370-00	11 - 14	J0B-K7387-00	4 - 34
JW9-F252M-00	2 - 4	J0B-F389G-00	20 - 2	JW9-F7263-00	6 - 49	JR1-G6511-00	8 - 25	JW1-H2510-00	18 - 40	JW1-K7387-00	22 - 11
JW9-F2535-00	2 - 7	JW1-F414G-10	22 - 1	JW8-F7280-00	7 - 13	JR1-G6512-00	8 - 26	JU2-H2510-20	18 - 44	J0B-K7389-00	14 - 5
J0B-F255G-00	2 - 2	J0B-F4161-00	11 - 2	JW8-F7281-00	7 - 5	JW8-G6514-00	8 - 31	JU2-H2511-00	18 - 42	J0B-K7458-00	21 - 2
J0B-F258E-00	2 - 12	J0B-F417A-00	22 - 17		7 - 16	JW8-G6521-00	8 - 37	JU2-H2517-20	16 - 19		21 - 7
J0B-F2873-01	12 - 15	JW8-F41B8-00	6 - 51	JW8-F7286-00	7 - 10	JW1-H1128-00	18 - 46	JU2-H2521-20	18 - 9	J0B-K7510-01	10 - 1
J0B-F2874-01	12 - 16	JW8-F4486-00	6 - 44		7 - 21	JU2-H1160-20	16 - 3	JU2-H2531-20	18 - 10	J0B-K7540-00	10 - 7
JW7-F312H-00	5 - 4		6 - 48	JW8-F7290-00	7 - 2	JU2-H1617-20	16 - 4	JU6-H2569-00	18 - 43	JU0-K7573-00	11 - 3
JW1-F3183-00	4 - 12	JW9-F4648-20	6 - 50	JW8-F7316-01	6 - 31	JU2-H1670-22	16 - 16	5UG-H2579-00	18 - 41	JOC-K7741-10	11 - 10
JW8-F3183-00	6 - 16	JW1-F467K-00	4 - 23	JW8-F7317-00	6 - 40	JW9-H1674-00	15 - 1	JOC-H2590-01	18 - 15	J0B-K7762-10	4 - 38

NUMERICAL INDEX

PART NO.	REF. NO.	PART NO.	REF. NO.	PART NO.	REF. NO.	PART NO.	REF. NO.	PART NO.	REF. NO.	PART NO.	REF. NO.
J0B-K7762-20	4 - 38	J0B-K817J-10	12 - 21	J0B-K8406-00	23 - 12	90114-12806	3 - 22	90461-14108	18 - 34	95602-12200	20 - 10
J0B-K7768-00	11 - 8	J0B-K818A-00	13 - 2	J0B-K8406-10	23 - 10	90119-06808	15 - 11	90464-14134	18 - 39	95602-14100	3 - 28
J0B-K7768-10	11 - 8	J0B-K818B-00	13 - 5			90119-10044	1 - 5	90464-20005	18 - 31	95612-12100	3 - 18
J0B-K7768-20	11 - 8	J0B-K8191-00	13 - 8	J0B-K8410-00	23 - 2	90159-06845	14 - 13	90464-25826	18 - 14	95802-10035	20 - 21
J0B-K8111-00	12 - 1	J0B-K8192-00	13 - 10	J0B-K8410-10	23 - 2	90170-08841	8 - 24	90464-40825	18 - 29	95812-08016	10 - 3
J0B-K8111-10	12 - 1	J0B-K819H-00	12 - 7	J0B-K8423-00	14 - 1	90170-10840	8 - 17	90464-48800	18 - 37	95812-08020	4 - 2
J0B-K8111-20	12 - 1	JW1-K8214-00	22 - 13	J0B-K8426-01	15 - 8	90176-06008	14 - 6	90464-76800	2 - 20		6 - 57
J0B-K8111-30	12 - 1	J0B-K821A-00	2 - 18	JW1-K8427-00	15 - 2	90179-05807	18 - 19	90468-20196	5 - 3	95812-08040	2 - 3
J0B-K8111-40	12 - 1	J0B-K8233-00	11 - 15	J0B-K8432-00	23 - 7	90179-08822	5 - 7	90506-14001	7 - 8	95812-08050	10 - 4
J0B-K8111-50	12 - 1	J0B-K8237-02	12 - 12	J0B-K8460-00	23 - 3	90179-08824	18 - 20		7 - 19	95812-10050	20 - 18
J0B-K8111-60	12 - 1	J0B-K8243-00	11 - 18	J0B-K8466-00	23 - 15	90179-12262	9 - 2	90506-20281	7 - 7	95812-10055	1 - 15
J0B-K8111-A0	12 - 1	J0B-K8244-00	11 - 20	J0B-K8473-00	23 - 5	90179-13800	1 - 4		7 - 18	95812-12065	1 - 7
J0B-K8111-B0	12 - 1	J0B-K8271-00	13 - 1	J0B-K8474-00	23 - 6	90183-05008	11 - 13	91402-25020	20 - 11	95812-12080	3 - 17
J0B-K8112-00	12 - 4	J0B-K8273-10	11 - 17	J0B-K8476-00	23 - 2	90185-06836	14 - 11	91490-25015	5 - 12	95822-06012	10 - 6
J0B-K8112-10	12 - 4	J0C-K827A-00	12 - 17	J0B-K8476-10	23 - 2	90185-12008	4 - 7	91490-30030	8 - 27	95822-06016	17 - 4
J0B-K8112-20	12 - 4	J0B-K8282-10	11 - 9	J0B-K8477-00	23 - 4	90201-04810	4 - 35	91702-08018	5 - 11	97012-08030	4 - 30
J0B-K8112-30	12 - 4	JW9-K8297-20	12 - 19	J0B-K8480-00	23 - 9	90201-05824	6 - 55	91702-10026	5 - 2	97012-10020	1 - 11
J0B-K8112-40	12 - 4	JW9-K8297-30	12 - 19	J0B-K8480-10	23 - 9	90201-068E2	16 - 27	92017-06040	14 - 4	9708R-06020	14 - 10
J0B-K8112-50	12 - 4	J0C-K8298-00	12 - 18	J0B-K8483-00	23 - 14	90201-08310	18 - 3	92902-08600	4 - 31	97602-05225	18 - 28
J0B-K8112-60	12 - 4	J0C-K8298-10	12 - 18	J0B-K8490-00	23 - 11	90201-121H8	7 - 12	92902-10100	1 - 12	99001-09600	5 - 10
J0B-K8112-A0	12 - 4	J0B-K8312-00	22 - 4	J0B-K8490-10	23 - 11		7 - 23	92902-10600	1 - 13		
J0B-K8112-B0	12 - 4	JW1-K8313-01	22 - 6	J0B-K84A0-00	22 - 2	90201-121H9	7 - 11	92902-12200	4 - 8		
J0B-K8114-01	11 - 6	JW1-K8314-10	22 - 12	J0B-K84A0-10	22 - 2		7 - 22	9299R-06200	14 - 14		
J0B-K8114-01	11 - 6	JW1-K8314-21	22 - 12	J0B-K84A2-00	22 - 3	90201-128S4	1 - 9	93101-24822	8 - 28		
J0B-K8115-00	11 - 1	J0B-K832F-00	11 - 22	JN9-W2536-00	7 - 3		20 - 24	93102-30083	3 - 26		
J0B-K8115-10	11 - 1	J0B-K832F-10	11 - 22		7 - 14	90201-208S8	20 - 4	93210-148B9	8 - 12		
J0B-K8115-20	11 - 1	J0B-K832G-00	11 - 23	90101-069U0	16 - 25	90208-14801	3 - 27	93210-478B8	8 - 5		
J0B-K8115-30	11 - 1	J0B-K832G-10	11 - 23	90101-08855	8 - 23	90215-06811	16 - 26	93306-00440	8 - 30		
J0B-K8115-40	11 - 1	JW1-K8340-00	14 - 3	90101-08856	8 - 21	90249-14129	5 - 9	93306-005Y1	8 - 6		
J0B-K8115-50	11 - 1	JW1-K834G-00	14 - 9	90101-10854	8 - 16	90269-06804	11 - 5	93306-005Y3	3 - 24		
J0B-K8115-60	11 - 1	JN6-K8355-20	14 - 8	90105-06831	2 - 16		13 - 4	93306-007Y0	8 - 14		
J0B-K8115-A0	11 - 1	JF2-K8356-00	14 - 7		11 - 4		13 - 7	93306-203X1	8 - 7		
J0B-K8115-B0	11 - 1	J0B-K8357-00	4 - 32		18 - 22		13 - 9	93306-204X0	3 - 23		
JW9-K811K-00	18 - 4	J0B-K8358-00	4 - 33	90105-08867	2 - 13		13 - 11	93306-303Y6	8 - 10		
J0C-K8141-00	12 - 10	J0B-K835E-00	11 - 11		18 - 35	90269-07805	11 - 7	93420-44805	8 - 29		
J0C-K8141-10	12 - 10	J0B-K8361-00	15 - 4	90105-088A9	20 - 13		11 - 19	93420-50804	8 - 4		
J0C-K8141-20	12 - 10	J0B-K8362-00	15 - 6	90105-088B6	2 - 17		11 - 21	95302-08700	10 - 5		
J0C-K8141-30	12 - 10	JN6-K8380-00	14 - 12	90105-10219	3 - 8		12 - 3	95302-10600	20 - 8		
J0C-K8141-40	12 - 10	J0B-K8388-00	22 - 7	90105-10267	3 - 13		12 - 6	95307-08700	5 - 8		
J0C-K8141-50	12 - 10	JU0-K8388-00	22 - 8		3 - 20		12 - 11	95602-06200	17 - 5		
J0C-K8141-60	12 - 10		22 - 14	90105-10373	3 - 6	90269-09003	11 - 16	95602-08100	20 - 15		
J0C-K8141-A0	12 - 10	JW1-K8388-00	22 - 5	90105-10840	8 - 2		13 - 3	95602-08200	20 - 14		
J0C-K8141-B0	12 - 10	JU0-K8398-00	22 - 10	90105-10847	4 - 28		13 - 6	95602-10200	1 - 16		
J0B-K8164-00	10 - 2		22 - 16	90105-13800	1 - 3	90381-17800	3 - 10		3 - 7		
J0B-K816M-00	2 - 15	J0A-K8401-00	15 - 3	90109-08002	14 - 2	90381-18801	3 - 2		10 - 8		
J0B-K817H-00	12 - 20	J0B-K8402-00	23 - 8		23 - 1	90386-12800	6 - 26	95602-12200	1 - 8		
J0B-K817H-10	12 - 20	JW1-K8402-10	15 - 10	90110-06125	15 - 9	90387-12016	3 - 15		4 - 9		
J0B-K817J-00	12 - 21	J0B-K8406-00	23 - 10	90111-05805	11 - 12	90387-241M7	3 - 25		20 - 6		