



# PARTS CATALOGUE

## DR2E20 ( J0C4 ) CANADA, EUROPE, OTHERS

---



1VJ0C-100E1

( )

DR2E20  
PARTS CATALOGUE  
©2019 by Yamaha Motor Co., Ltd.  
1st edition, June 2019  
All rights reserved.  
Any reprinting or unauthorized use  
without the written permission of  
Yamaha Motor Co., Ltd.  
is expressly prohibited.  
Printed in Japan.

# FOREWORD

This Parts Catalogue is related to the parts for the model(s) on the cover page. When you are ordering replacement parts, please refer to this Parts Catalogue and quote both part numbers and part names correctly.

1. Modifications or additions which have been made after the issue of the Parts Catalogue will be announced in the Parts News.  
It is advisable that you make the necessary corrections to the Parts Catalogue according to the Parts News.

2. Abbreviations

The following abbreviations are used in this Parts Catalogue.

“UR” Use specified parts number.

“UN” Use as many as needed.

“AP” Alternate Parts

“LM” Locally Made (Parts need to be ordered locally)

“F#” Frame No. (Applicable machine No.)

“O/S” Over Size

3. The number of components for assembly

- Parts, which are to be supplied in an assembly, are listed with a dot (.) in front of the part name as shown below.
- The numeral appearing to the right of each component part indicates the quantity of parts for each assembly unit.

PART NO.	DESCRIPTION	Q'TY	REMARKS
2F5-83310-60	FRONT FLASHER LIGHT ASSY	2	
115-83311-60	.BULB (6V-18W)	1	

4. Applicable colours of graphics are represented in the “REMARKS” as shown below.

PART NO.	DESCRIPTION	Q'TY	REMARKS
2N4-24110-00-X5	FUEL TANK COMP.	2	MXR
3J1-24240-10	.GRAPHIC, FUEL TANK	1	FOR MXR

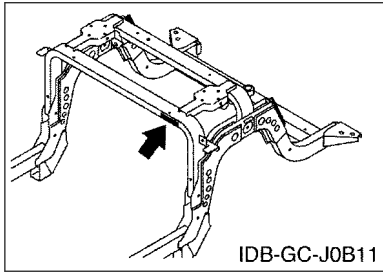
5. Note that the illustrations for reference in finding parts numbers are not to be used for assembling. When assembling, please use the applicable service manual.

6. The asterisk (\*) before a reference number indicates modified items after the first edition.

# FOREWORD

## 7. Applicable Serial No.

Frame Serial No.



## 8. Applicable Colour Code (The (\*) mark shows Model colour.)

Abbreviation	Colour Name	Colour Code
BW1(*)	BLUISH WHITE 1	1571
DNBME(*)	DARK GRAYISH BLUE METALLIC E	0866
DNMC(*)	DARK GRAY METALLIC C	0922
HTR(*)	HEAT RED	00EY
LNMP(*)	LIGHT GRAY METALLIC P	0925
MDBM2(*)	MAT DARK BLUE METALLIC 2	1712
NYM6(*)	GRAYISH YELLOW METALLIC 6	1796
NYS4(*)	GRAYISH YELLOW SOLID 4	1459
VDGS1(*)	VERY DARK GREEN SOLID 1	0614

## 9. Quantity Column Information

Column No.	Name Of Q'ty Column	Destination
1	J0C4	CANADA, EUROPE, OTHERS

## 10. Applicable Starting Serial No.

Frame Serial No.

Serial No.	Name Of Q'ty Column	Model Code
J0C-300101	J0C4	J0C4

# CONTENTS

## BODY

REAR ARM & SUSPENSION.....	1
FRAME.....	2
FRONT SUSPENSION.....	3
STEERING.....	5
PEDAL WIRE.....	7
PEDAL ASSEMBLY.....	8
BRAKE.....	11

## DRIVE

TRANSAXLE.....	12
WHEEL.....	14
BUMPER.....	15
BODY.....	16
BODY 2.....	18
BODY FITTING.....	20
CARRIER.....	21
SEAT.....	22

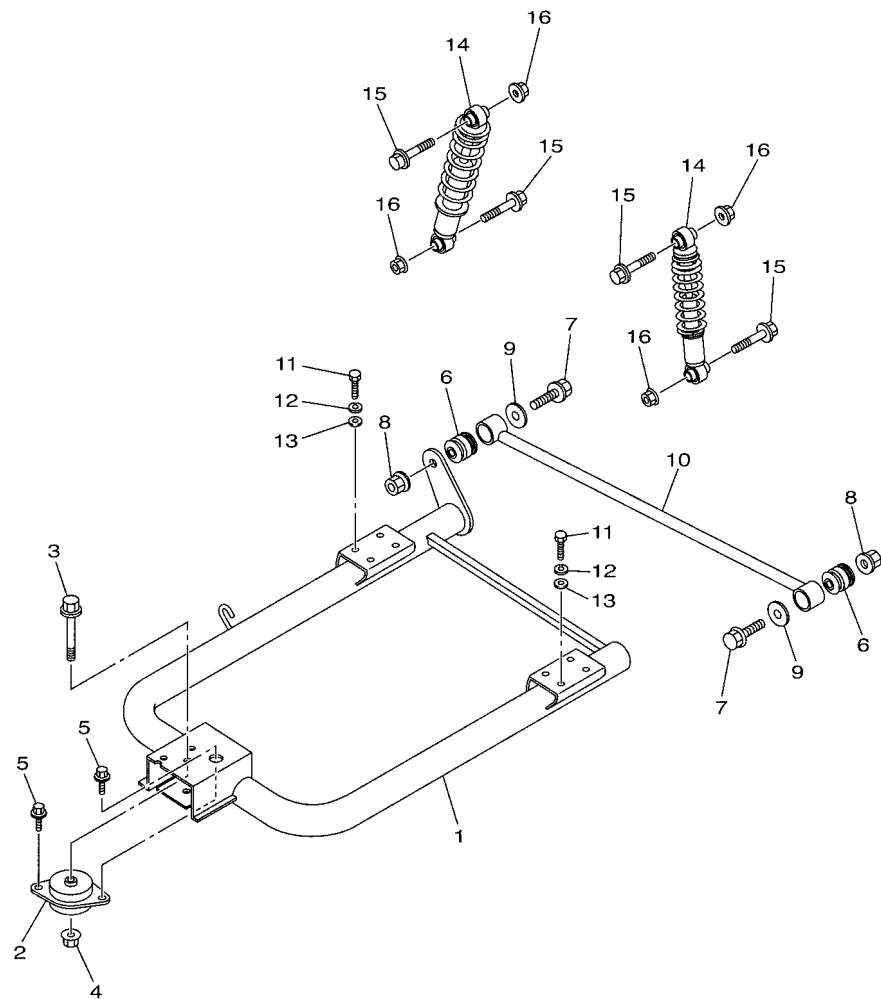
## ELECTRICAL

ELECTRIC MOTOR.....	23
CONTROLLER 1.....	25
ELECTRICAL 1.....	26
BATTERY CHARGER.....	28
ALTERNATE FOR CHASSIS.....	29
ALTERNATE FOR WINDSHIELD.....	31
ALTERNATE FOR SUN ROOF.....	33
ALTERNATE FOR SEAT.....	34

## INDEX

NUMERICAL INDEX.....	35
----------------------	----

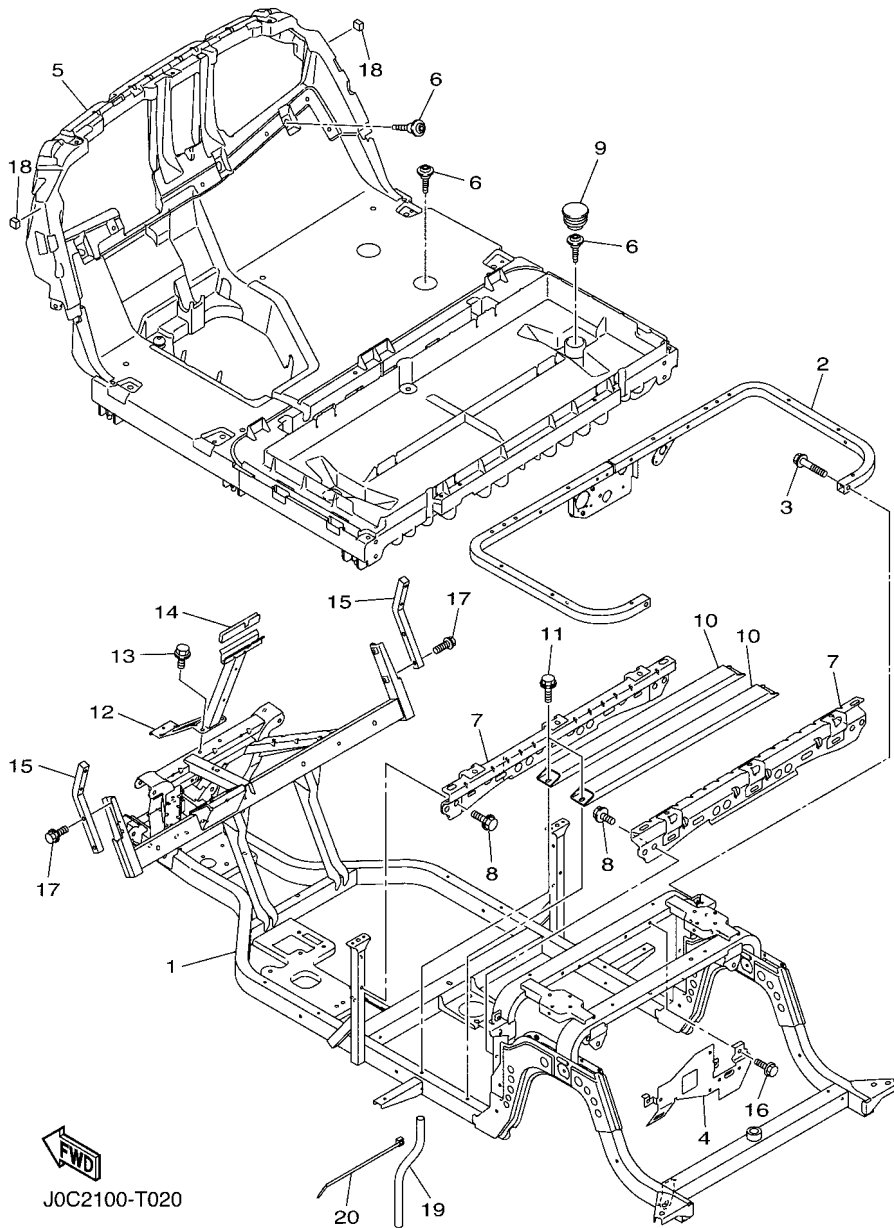
**FIG. 1 REAR ARM & SUSPENSION**



REF. NO.	PART NO.	DESCRIPTION	J0C4				REMARKS
1	J0C-F2110-00	REAR ARM COMP.	1				
2	JN6-F2123-20	BUSH 1	1				
3	90105-13800	BOLT, FLANGE	1				
4	90179-13800	NUT	1				
5	90119-10044	BOLT, WITH WASHER	2				
6	JN6-F2124-10	BUSH 2	2				
7	95812-12065	BOLT, FLANGE	2				
8	90185-12811	NUT, SELF-LOCKING	2				
9	90201-128S4	WASHER, PLATE	2				
10	JW1-F217G-10	ROD, CONNECTING 2	1				
11	97012-10020	BOLT	8				
12	92902-10100	WASHER, SPRING	8				
13	92902-10600	WASHER, PLATE	8				
14	J0C-F2210-00	SHOCK ABSORBER ASSY, REAR	2				
15	95812-10055	BOLT, FLANGE	4				
16	95602-10200	NUT, S/L FLANGE	4				



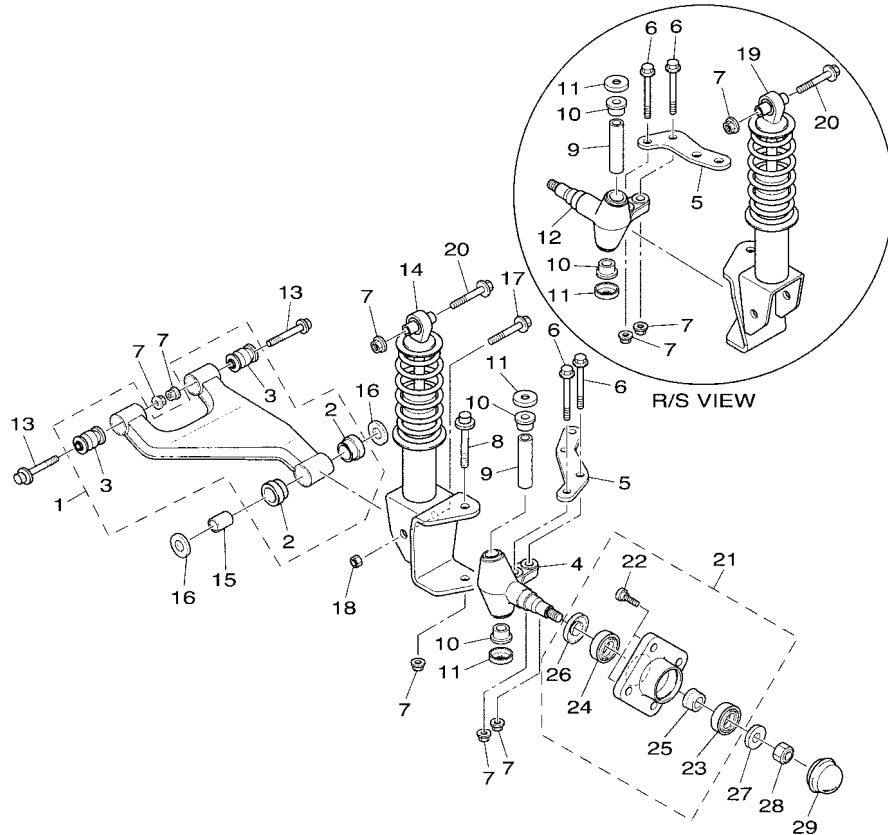
J0C1110-S010



**FIG. 2 FRAME**

REF. NO.	PART NO.	DESCRIPTION	JOC4				REMARKS
1	J0A-F2501-10	FRAME COMP.	1				
2	J0B-F255G-00	MEMBER, SEAT SUPPORT	1				
3	95812-08040	BOLT, FLANGE	2				
4	JW9-F252M-00	BRACKET, 3	1				
5	J0C-F7411-01	FOOTREST 1	1				
6	J0B-F1738-00	BOLT	9				
7	JW9-F2535-00	STAY, BATTERY 1	2				
8	JW1-F1738-00	BOLT	4				
9	JW9-F2417-00	PLUG	2				
10	JW9-F2198-10	MEMBER, CROSS	2				
11	JW1-F1738-00	BOLT	4				
12	J0B-F258E-10	SUPPORT, FRONT COWL	1				
13	90105-08867	BOLT, FLANGE	2				
14	J0B-F2127-00	SHIM	1				
15	J1B-K816M-00	SUPPORT, HOLDER	2				
16	90105-06831	BOLT, FLANGE	3				
17	90105-088B6	BOLT, FLANGE	4				
18	J0B-K821A-00	PAD, BODY MOUNTING1	2				
19	J0B-F125J-00	PIPE, DRAIN	2				
20	90464-76800	CLAMP	2				

**FIG. 3 FRONT SUSPENSION**



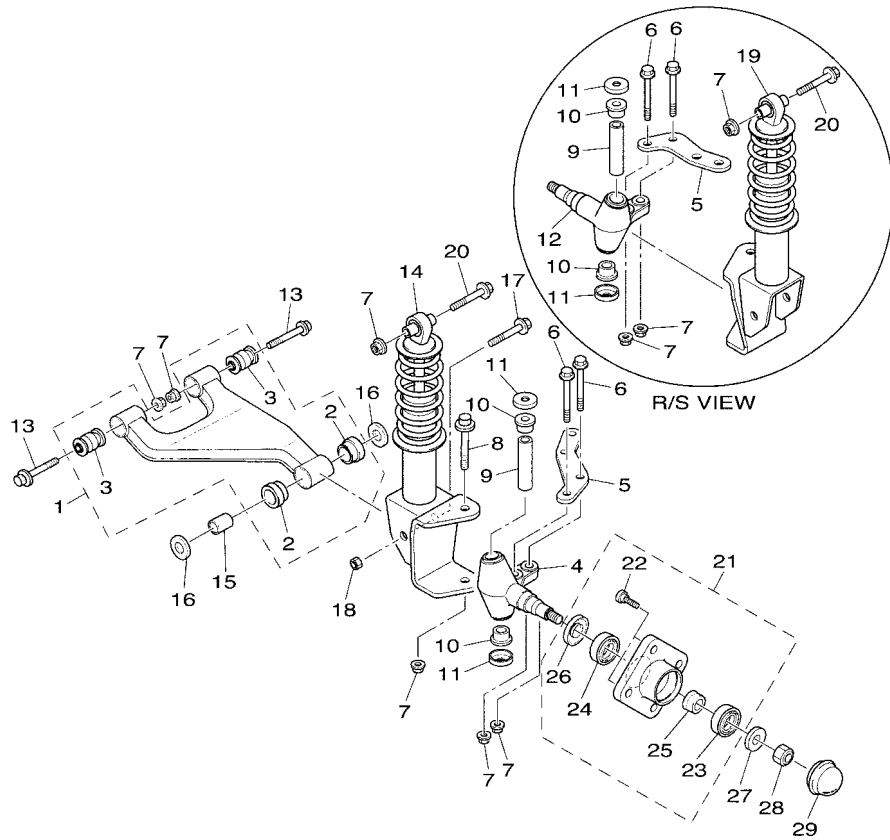
REF. NO.	PART NO.	DESCRIPTION	J0C4	REMARKS
1	J0B-F3570-10	FRONT LOWER ARM COMP. (LEFT)	2	
2	90381-18801	.BUSH, SOLID	2	
3	2HR-23526-00	.BUSH	2	
4	JU0-F3511-20	KNUCKLE, STEERING 1	1	
5	JW1-F3512-00	ARM, KNUCKLE 1	2	
6	90105-10373	BOLT, FLANGE	4	
7	95602-10200	NUT, S/L FLANGE	12	
8	90105-10219	BOLT, FLANGE	2	
9	2NL-23448-00	SPACER	2	
10	90381-17800	BUSH, SOLID	4	
11	2NL-23517-00	COVER, THRUST 1	4	
12	JU0-F3521-20	KNUCKLE, STEERING 2	1	
13	90105-10267	BOLT, FLANGE	4	
14	J0C-F3350-00	SHOCK ABSORBER ASSY	1	
15	90387-12016	COLLAR	2	
16	401-22128-01	COVER, THRUST 1	4	
17	95812-12080	BOLT, FLANGE	2	
18	90185-12810	NUT, SELF-LOCKING	2	
19	J0C-F3390-00	SHOCK ABSORBER ASSY 2	1	
20	90105-10267	BOLT, FLANGE	2	
21	JW8-F5103-00	HUB BEARING UNIT ASSY	2	
22	90114-12806	.BOLT, SERRATION	4	
23	93306-204X0	.BEARING	1	
24	93306-005Y3	.BEARING	1	
25	90387-241M7	.COLLAR	1	
26	93102-30083	.OIL SEAL	1	
27	90208-14801	WASHER, CONICAL SPRING	2	



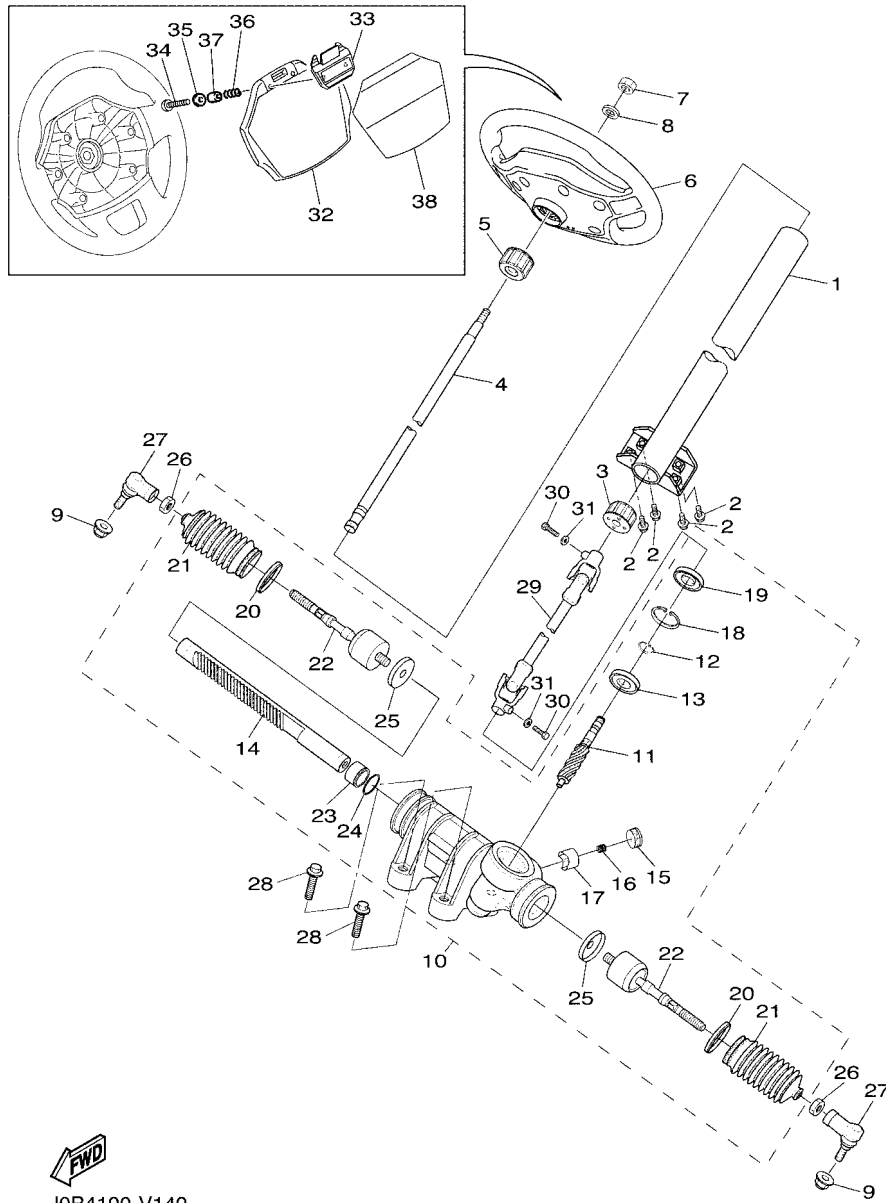
J0C4100-V030



**FIG. 3 FRONT SUSPENSION**



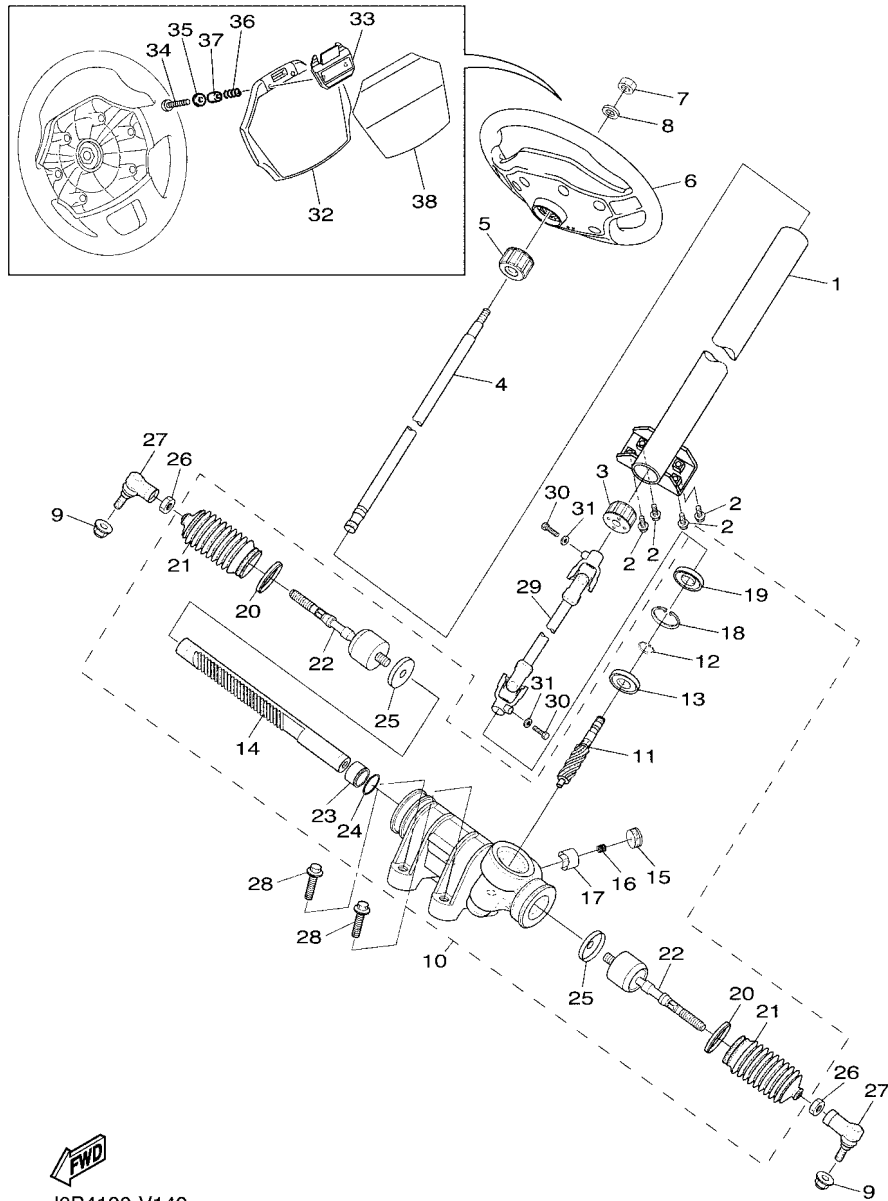
REF. NO.	PART NO.	DESCRIPTION	J0C4			REMARKS
28	95602-14100	NUT, U	2			
29	JN6-F5118-01	COVER, HUB DUST	2			



J0B4100-V140

FIG. 4 STEERING

REF. NO.	PART NO.	DESCRIPTION	J0C4	REMARKS
1	J0G-F3811-00	COLUMN, STEERING	1	
2	95812-08020	BOLT, FLANGE	4	
3	JU0-F3857-20	HOLDER	1	
4	JU0-F3828-10	ROD, STEERING	1	
5	JU0-F3857-20	HOLDER	1	
6	J0A-F3838-00	WHEEL, STEERING	1	
7	90185-12008	NUT, SELF-LOCKING	1	
8	92902-12200	WASHER	1	
9	90185-12811	NUT, SELF-LOCKING	2	
10	JW1-F3400-00	STEERING ASSY	1	
11	JW1-F387A-00	.GEAR, PINION	1	
12	JW1-F3183-00	.CIRCLIP	1	
13	JW1-F3812-00	.BEARING, STEERING	1	
14	JW1-F387E-00	.GEAR, RACK	1	
15	5UG-F387G-00	.COVER, ADJUST	1	
16	5UG-F387K-00	.SPRING, PRESSURE	1	
17	5UG-F387F-00	.PAD, PRESSURE	1	
18	5UG-F387J-00	.RING, STOPPER	1	
19	5UG-F3844-00	.SEAL	1	
20	5UG-F3489-00	.BAND	2	
21	5UG-F3527-00	.SEAL, DUST 1	2	
22	JW1-F3837-00	.ROD, TIE 2	2	
23	JW1-F467K-00	.BUSH, CAP	1	
24	JW1-F3866-00	.CIRCLIP	1	
25	JW1-F3894-00	.WASHER, LOCK 1	2	
26	1P0-F3833-00	NUT 1	2	
27	JW8-23841-01	JOINT, UNIVERSAL 1	2	

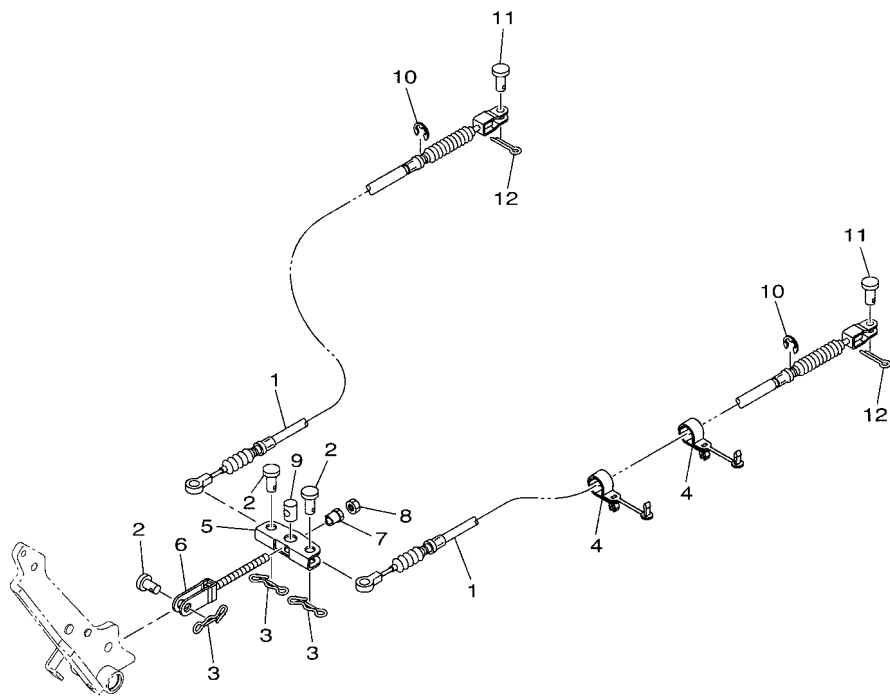


J0B4100-V140

FIG. 4 STEERING

REF. NO.	PART NO.	DESCRIPTION	J0C4				REMARKS
28	90105-10847	BOLT, FLANGE	4				
29	JW1-F3822-01	JOINT 1	1				
30	97012-08030	BOLT	2				
31	92902-08600	WASHER, PLATE	2				
32	J0B-K8357-00	HOLDER 1	1				
33	J0B-K8358-00	HOLDER 2	1				
34	J0B-K7387-00	SCREW	2				
35	90201-04810	WASHER, PLATE	2				
36	J0B-K7363-00	SPRING	2				
37	J0B-K7115-00	COLLAR	2				
38	J0B-K7762-10	LABEL, WARNING 2	1				UR ENGLISH/FRENCH
	J0B-K7762-20	LABEL, WARNING 2	1				UR GERMAN/SPANISH

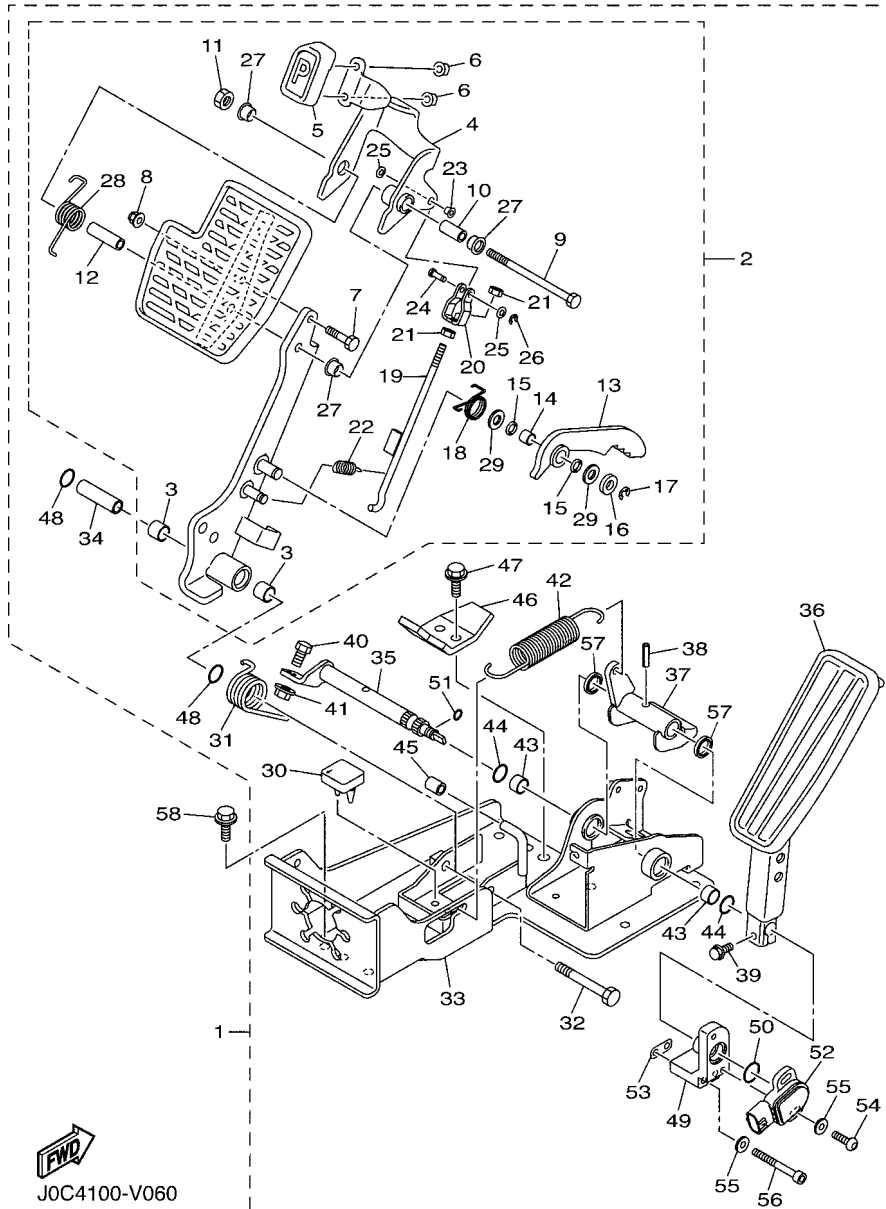
**FIG. 5 PEDAL WIRE**



REF. NO.	PART NO.	DESCRIPTION	JOC4				REMARKS
1	JW9-F6351-10	CABLE, BRAKE	2				
2	91702-10026	PIN, CLEVIS	3				
3	90468-20196	CLIP	3				
4	JW7-F312H-00	CLAMP	4				
5	JW8-F5681-10	EQUALIZER, BRAKE	1				
6	JN6-F5685-01	ROD	1				
7	90179-08822	NUT	1				
8	95307-08700	NUT	1				
9	90249-14129	PIN	1				
10	99001-09600	CIRCLIP	2				
11	91702-08018	PIN, CLEVIS	2				
12	91490-25015	PIN, COTTER	2				



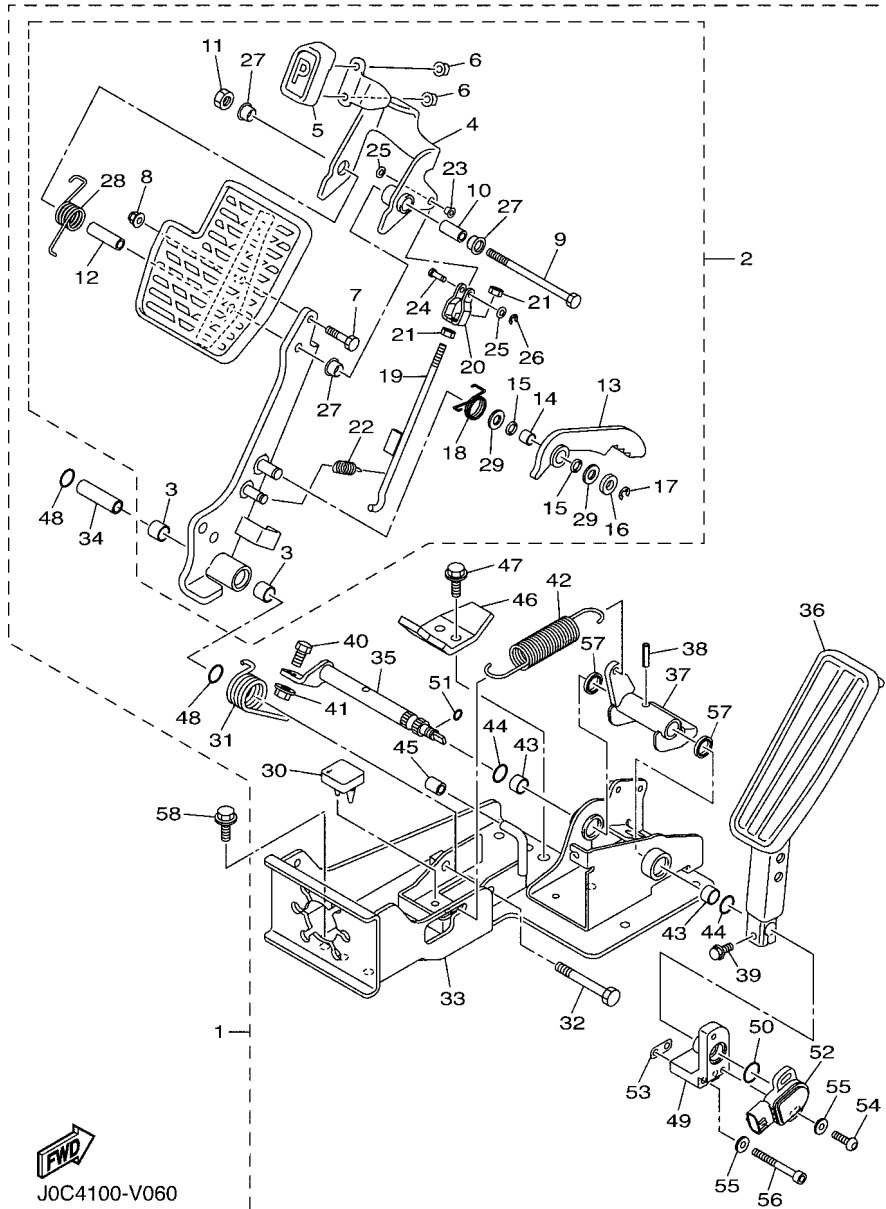
JW97110-R050



J0C4100-V060

FIG. 6 PEDAL ASSEMBLY

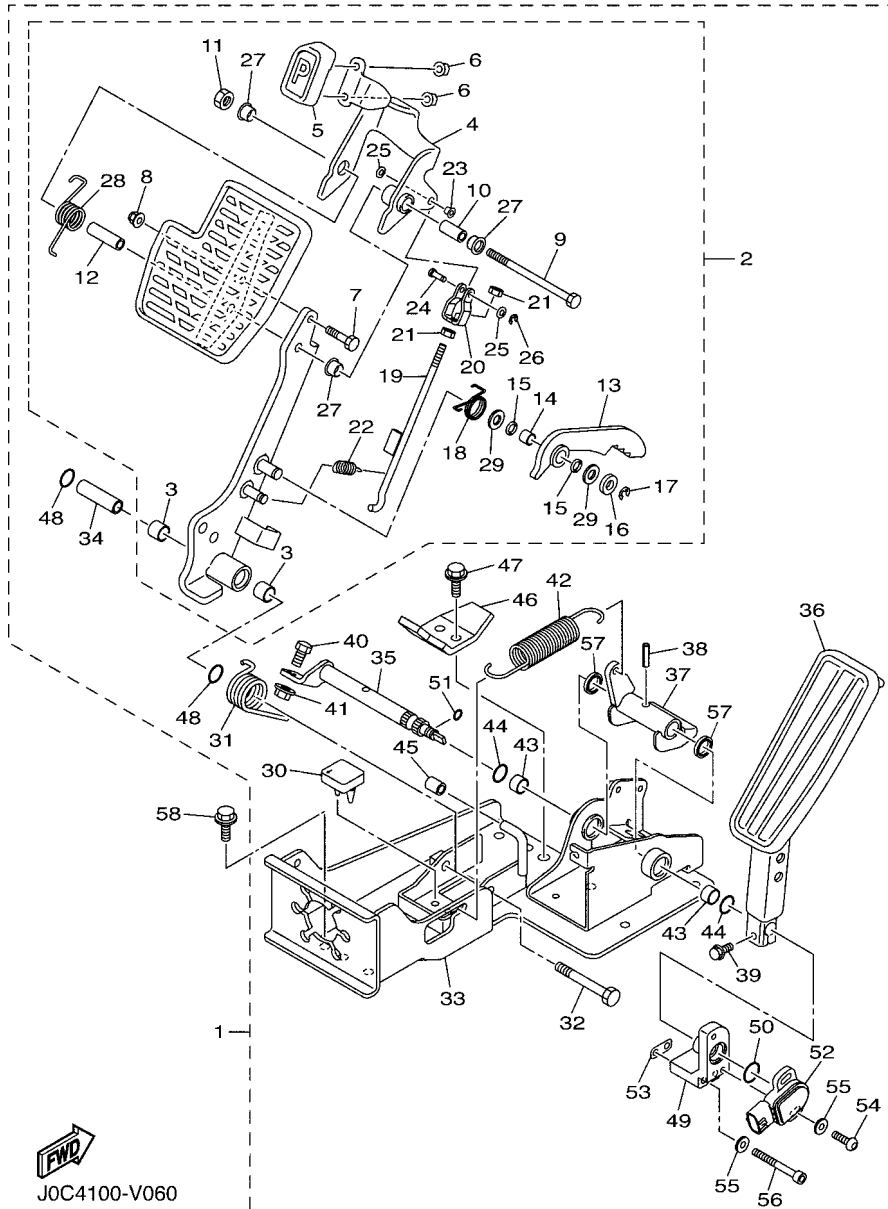
REF. NO.	PART NO.	DESCRIPTION	J0C4	REMARKS
1	J0H-F7850-20	PEDAL ASSY (L.H)	1	
2	J0G-F7200-02	.PEDAL, BRAKE	1	
3	JW8-F7814-21	.BUSH, PEDAL	2	
4	J0G-F5671-00	..PEDAL, PARKING BRAKE	1	
5	J0G-F7854-00	..COVER, PEDAL	1	
6	95607-06200	..NUT, SELF U-FLANGE	2	
7	97012-06020	..BOLT	1	
8	JW8-F8363-00	..NUT	1	
9	J0G-F7416-00	..BOLT, FOOTREST	1	
10	JW8-F639N-00	..COLLAR	1	
11	J0G-F7218-00	..NUT	1	
12	J0G-F7313-00	..COLLAR	1	
13	JW9-F5666-00	..SECTOR, PARKING BRAKE	1	
14	JW8-F7121-00	..BUSH	1	
15	JW9-F7221-00	..SEAL, SHAFT	2	
16	JW8-F7322-00	..WASHER	1	
17	JW8-F3183-00	..CIRCLIP	1	
18	JW8-F7426-01	..SPRING, RETURN	1	
19	JW9-F7231-10	..ROD, BRAKE	1	
20	JW9-F7232-00	..END, ROD 2	1	
21	JW8-F7318-00	..NUT	2	
22	JW8-F6314-00	..SPRING	1	
23	J0G-F7814-00	..BUSH, PEDAL	1	
24	JW9-F7228-00	..PIN, JOINT	1	
25	JW8-F8323-00	..WASHER, LEG SHIELD	2	
26	JW8-F5415-00	..CIRCLIP	1	
27	90386-12800	..BUSH	3	



J0C4100-V060

FIG. 6 PEDAL ASSEMBLY

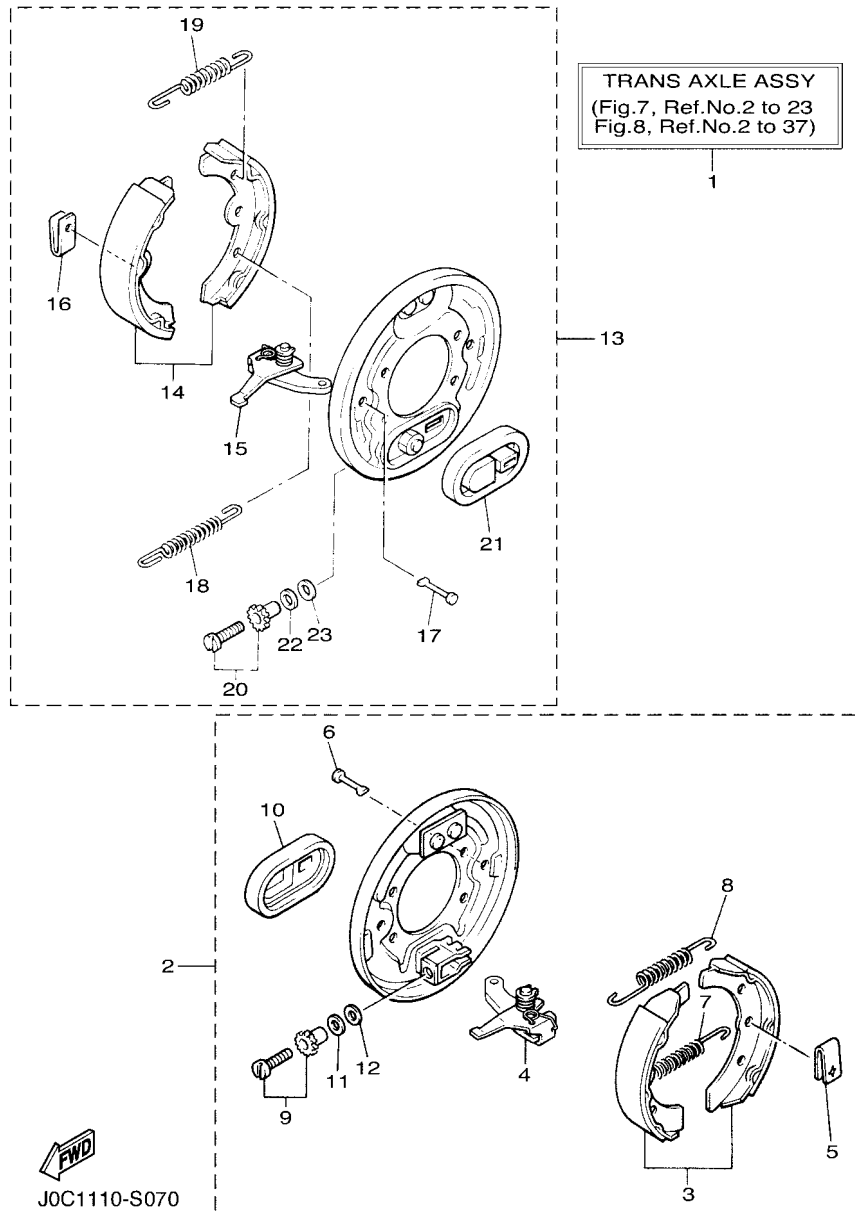
REF. NO.	PART NO.	DESCRIPTION	J0C4	REMARKS
28	J0G-F7825-00	.SPRING, RETURN	1	
29	JW8-F7119-00	.WASHER	2	
30	JW9-F7245-10	.PAD, BRAKE PEDAL	1	
31	JW8-F7316-01	.SPRING, SIDE STAND	1	
32	JW8-F7217-00	.BOLT	1	
33	J0H-F7445-10	.PLATE 1	1	
34	JW8-F7213-20	.COLLAR	1	
35	J0H-F7853-10	.SHAFT, PEDAL 1	1	
36	J0G-F7871-01	.PEDAL, ACCELERATOR	1	
37	J0H-F7872-00	.ARM, ACCELERATOR PEDAL	1	
38	JW8-F7438-00	.PIN, CLEVIS	1	
39	JW8-F7434-00	.BOLT	1	
40	JW8-F7317-00	.BOLT	1	
41	JW8-F7118-00	.NUT	1	
42	J0G-F815H-10	.SPRING	1	
43	J0G-F5922-00	.WASHER	2	
44	JW8-F4486-00	.O-RING	2	
45	JW9-F5673-00	.DAMPER, BRAKE	1	
46	JW9-F7246-20	.NAIL, BRAKE	1	
47	JW8-F8331-00	.BOLT, LEG SHIELD	2	
48	JW8-F4486-00	.O-RING	2	
49	JW9-F7263-00	.BRACKET 1	1	
50	JW9-F4648-20	.O-RING	1	
51	JW8-F41B8-00	.O-RING	1	
52	JW9-H5885-00	.THROTTLE SENSOR ASSY	1	
53	JW9-F5827-00	.SHIM, CALIPER	1	T: 0.5 MM
	JW9-F5827-10	.SHIM, CALIPER	1	T: 0.9 MM



  
J0C4100-V060

**FIG. 6 PEDAL ASSEMBLY**

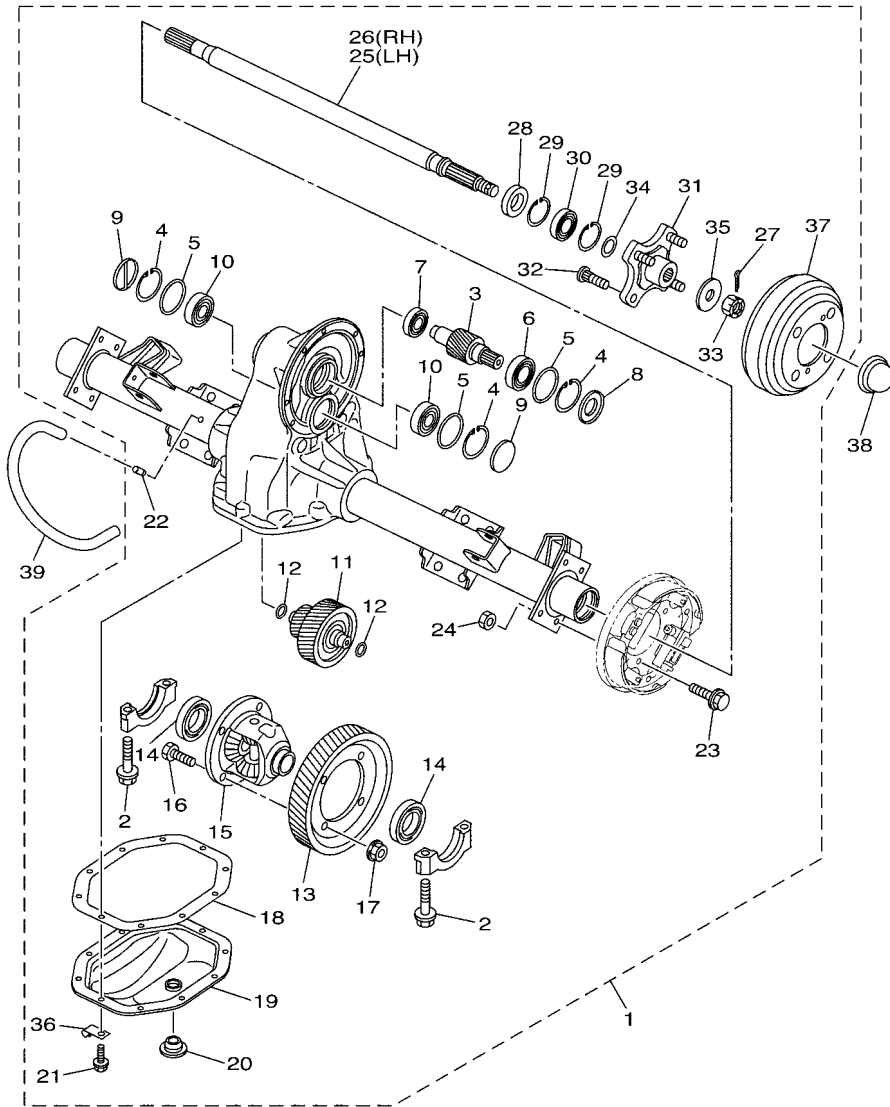
REF. NO.	PART NO.	DESCRIPTION	J0C4			REMARKS
54	JW9-F632G-00	.SCREW	2			
55	90201-05824	.WASHER, PLATE	4			
56	JW8-F7435-00	.BOLT	2			
57	J0G-F3145-00	.OIL SEAL	2			
58	95812-08020	BOLT, FLANGE	6			



**FIG. 7 BRAKE**

REF. NO.	PART NO.	DESCRIPTION	J0C4	REMARKS
1	J0C-G6300-01	TRANS AXLE ASSY	1	
2	JW8-F7290-10	..BACKING PLATE ASSY 2	1	
3	JN9-W2536-11	..BRAKE SHOE SET	1	
4	J38-27205-00	..LEVER ASSY 2	1	
5	JW8-F7281-00	..SPRING, SHOE CLAMP	2	
6	J10-27282-00	..PIN, SHOE HOLD DOWN	2	
7	90506-20281	..SPRING, TENSION	1	
8	90506-14001	..SPRING, TENSION	1	
9	J55-27260-00	..ADJUSTER ASSY	1	
10	JW8-F7286-00	..COVER, DUST	1	
11	90201-121H9	..WASHER, PLATE	1	
12	90201-121H8	..WASHER, PLATE	1	
13	JW8-F7280-10	..BACKING PLATE ASSY 1	1	
14	JN9-W2536-11	..BRAKE SHOE SET	1	
15	J38-27204-00	..LEVER ASSY 1	1	
16	JW8-F7281-00	..SPRING, SHOE CLAMP	2	
17	J10-27282-00	..PIN, SHOE HOLD DOWN	2	
18	90506-20281	..SPRING, TENSION	1	
19	90506-14001	..SPRING, TENSION	1	
20	J55-27270-00	..ADJUSTER ASSY	1	
21	JW8-F7286-00	..COVER, DUST	1	
22	90201-121H9	..WASHER, PLATE	1	
23	90201-121H8	..WASHER, PLATE	1	



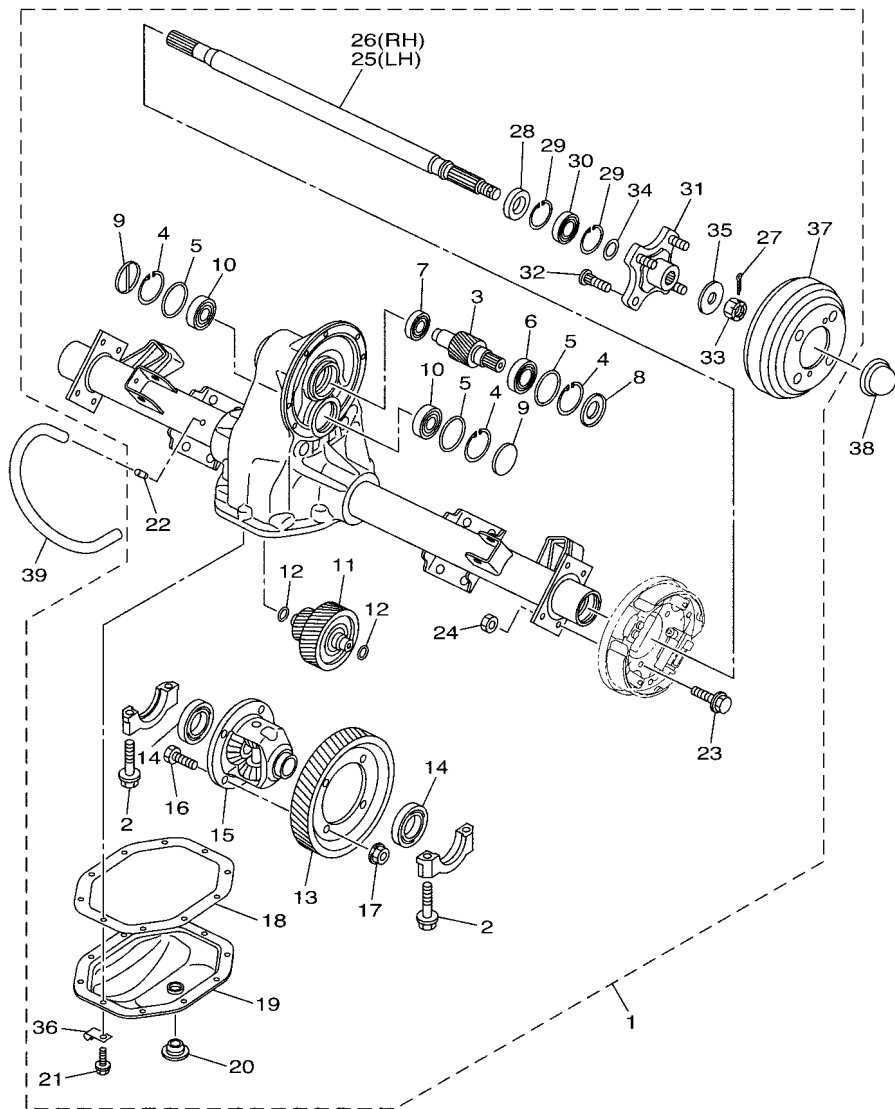


J0C1110-S080

FIG. 8 TRANSAXLE

REF. NO.	PART NO.	DESCRIPTION	J0C4				REMARKS
1	J0C-G6300-01	TRANS AXLE ASSY	1				
2	90105-10840	.BOLT, FLANGE	4				
3	JW9-G6321-00	.SHAFT, INPUT	1				
4	93420-50804	.CIRCLIP	3				
5	93210-478B8	.O-RING	3				
6	93306-005Y1	.BEARING	1				
7	93306-203X1	.BEARING	1				
8	JW9-G6136-00	.SEAL 1	1				
9	JH7-G3396-01	.PLUG, BLIND	2				
10	93306-303Y6	.BEARING	2				
11	JW9-G6350-00	.COUNTER GEAR ASSY	1				
12	93210-148B9	.O-RING	2				
13	JW9-G6421-00	.GEAR, RING	1				
14	93306-007Y0	.BEARING	2				
15	JW9-G6410-00	.DIFFERENTIAL ASSY.	1				
16	90101-10854	.BOLT	4				
17	90170-10840	.NUT	4				
18	JW9-G631A-00	.GSKT., CASE	1				
19	JW9-G6312-00	.CASE, TRANSMISSION 2	1				
20	JN3-G6432-00	.STOPPER	1				
21	90101-08856	.BOLT	10				
22	JW8-G5378-00	.NIPPLE, HOSE	1				
23	90101-08855	.BOLT	8				
24	90170-08841	.NUT	8				
25	JR1-G6511-00	.SHAFT, REAR AXLE 1 (L.H)	1				
26	JR1-G6512-00	.SHAFT, REAR AXLE 2 (R.H)	1				
27	91490-30030	.PIN. COTTER	2				

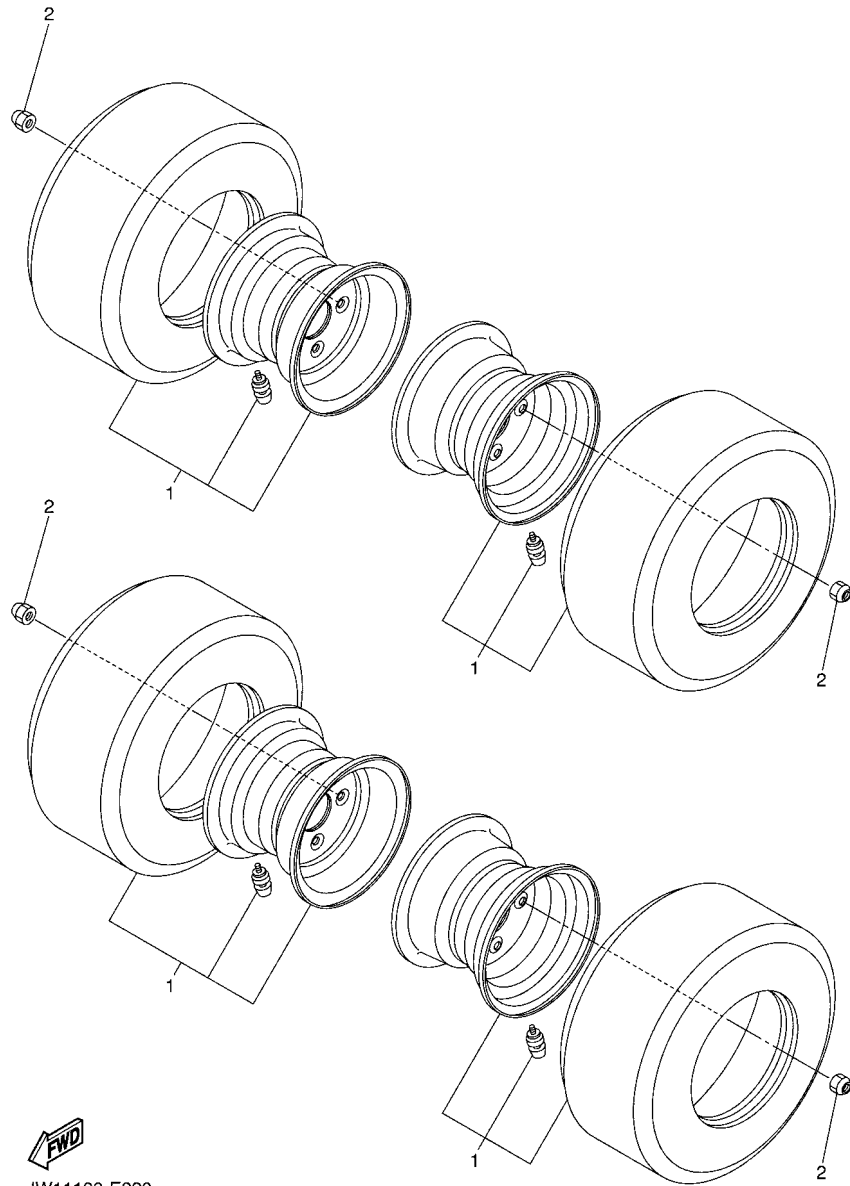
**FIG. 8 TRANSAXLE**



REF. NO.	PART NO.	DESCRIPTION	JOC4				REMARKS
28	93101-24822	.OIL SEAL	2				
29	93420-44805	.CIRCLIP	4				
30	93306-00440	.BEARING	2				
31	JW8-G6514-00	.HUB, REAR AXLE	2				
32	JW8-G4178-00	.BOLT, STUD	8				
33	JW8-G5244-00	.NUT	2				
34	JW8-G2535-00	.WASHER, THRUST	2				
35	JW8-G2536-00	.WASHER, THRUST 2	2				
36	JW8-G2756-00	.STAY, CLAMP	1				
37	JW8-G6521-00	.DRUM	2				
38	JW8-F5118-00	COVER, HUB DUST	2				
39	JW8-G2541-00	PIPE 1	1				



J0C1110-S080

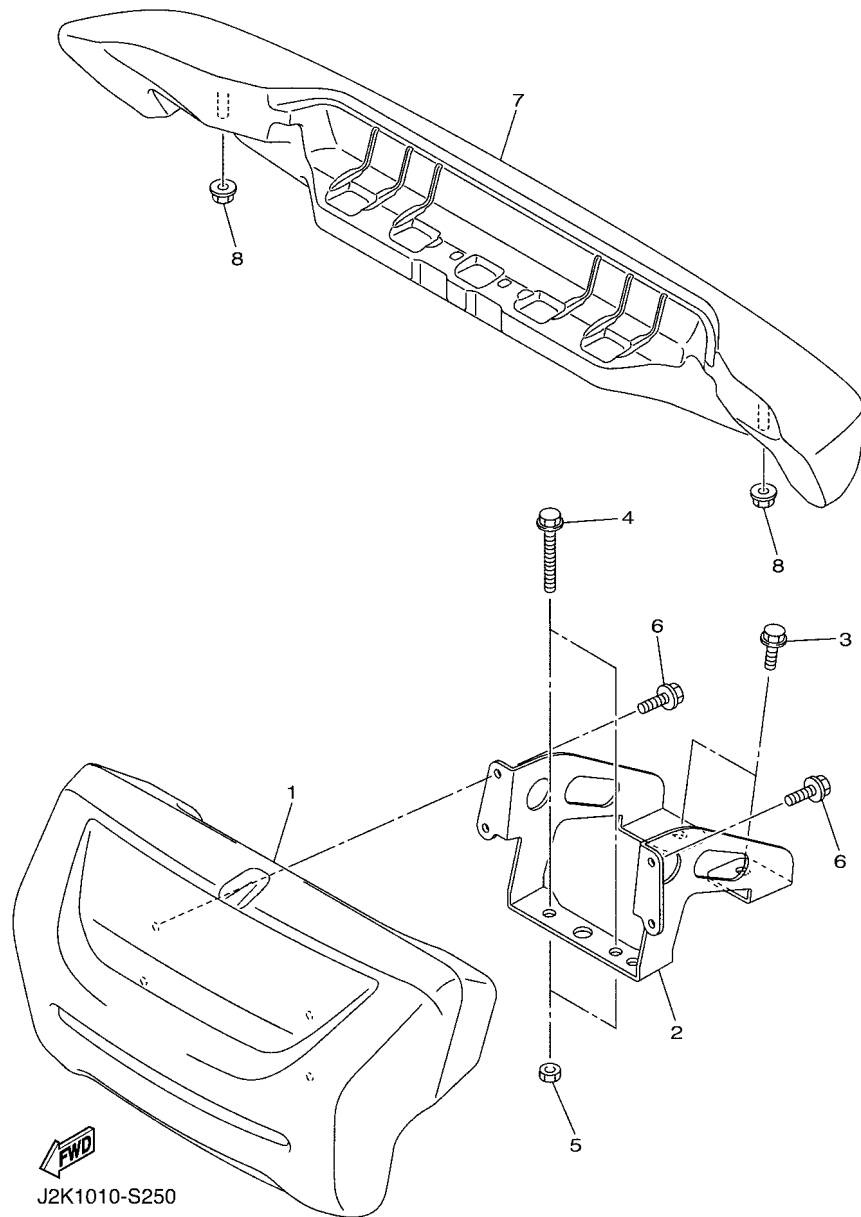


JW11100-E220

FIG. 9 WHEEL

REF. NO.	PART NO.	DESCRIPTION	JQC4				REMARKS
1	JW1-F5100-01	WHEEL ASSY (18X8.50-8-4PLY)	4				
2	90179-12262	NUT	16				

**FIG. 10 BUMPER**



REF. NO.	PART NO.	DESCRIPTION	JOC4				REMARKS
1	J0B-K7510-01	FRONT BUMPER COMP.	1				
2	J0B-K8164-00	STAY, FRONT BUMPER (L.H)	1				
3	95812-08016	BOLT, FLANGE	2				
4	95812-08050	BOLT, FLANGE	2				
5	95302-08700	NUT, HEXAGON	2				
6	95822-06012	BOLT, FLANGE	4				
7	J0B-K7540-00	REAR BUMPER COMP.	1				
8	95602-10200	NUT, S/L FLANGE	2				

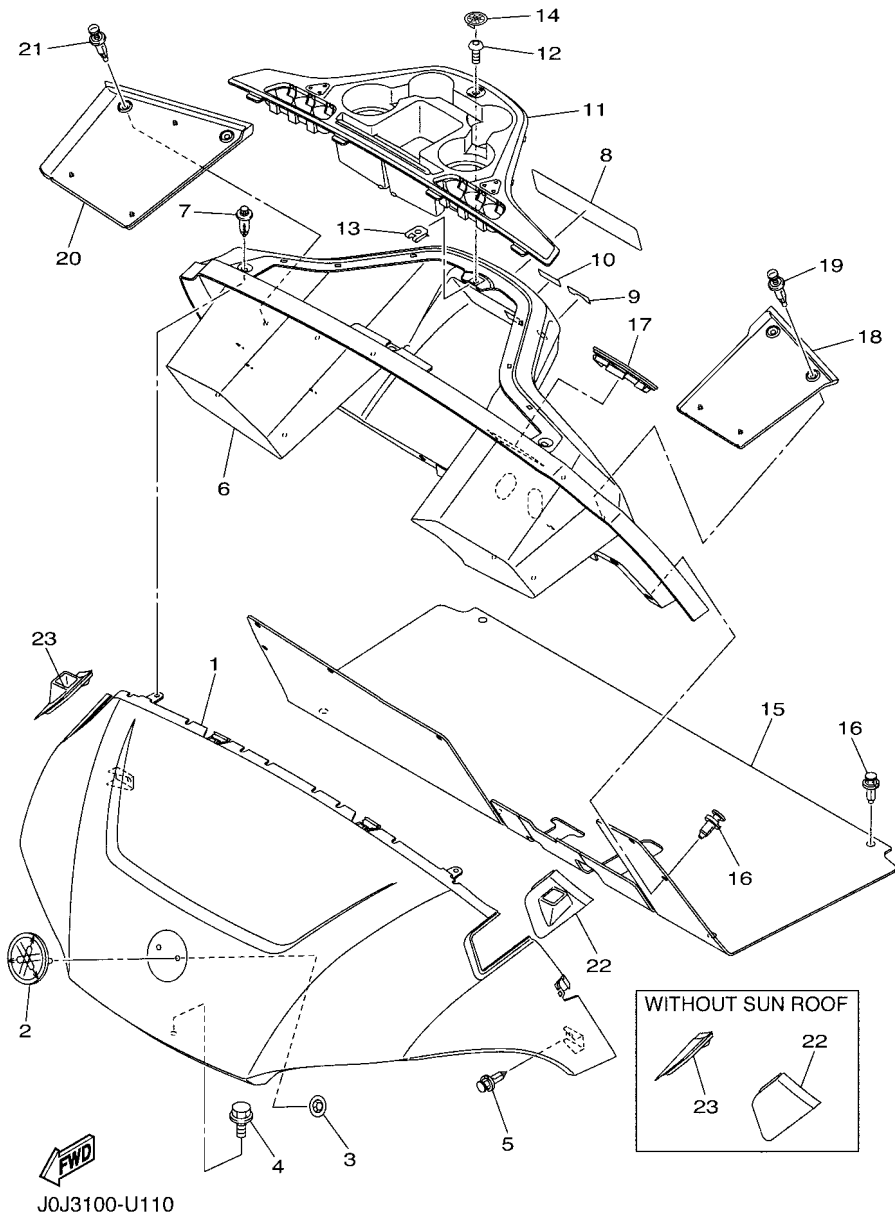
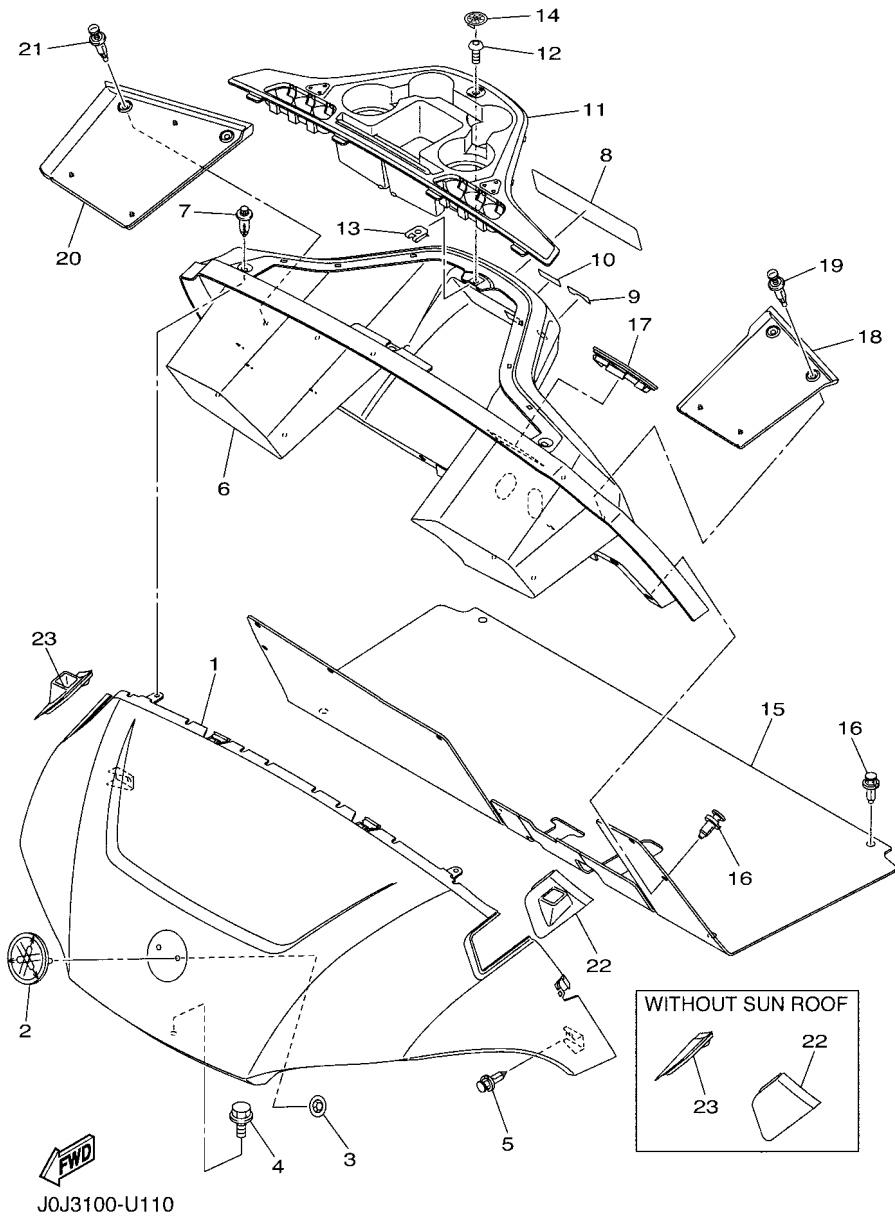


FIG. 11 BODY

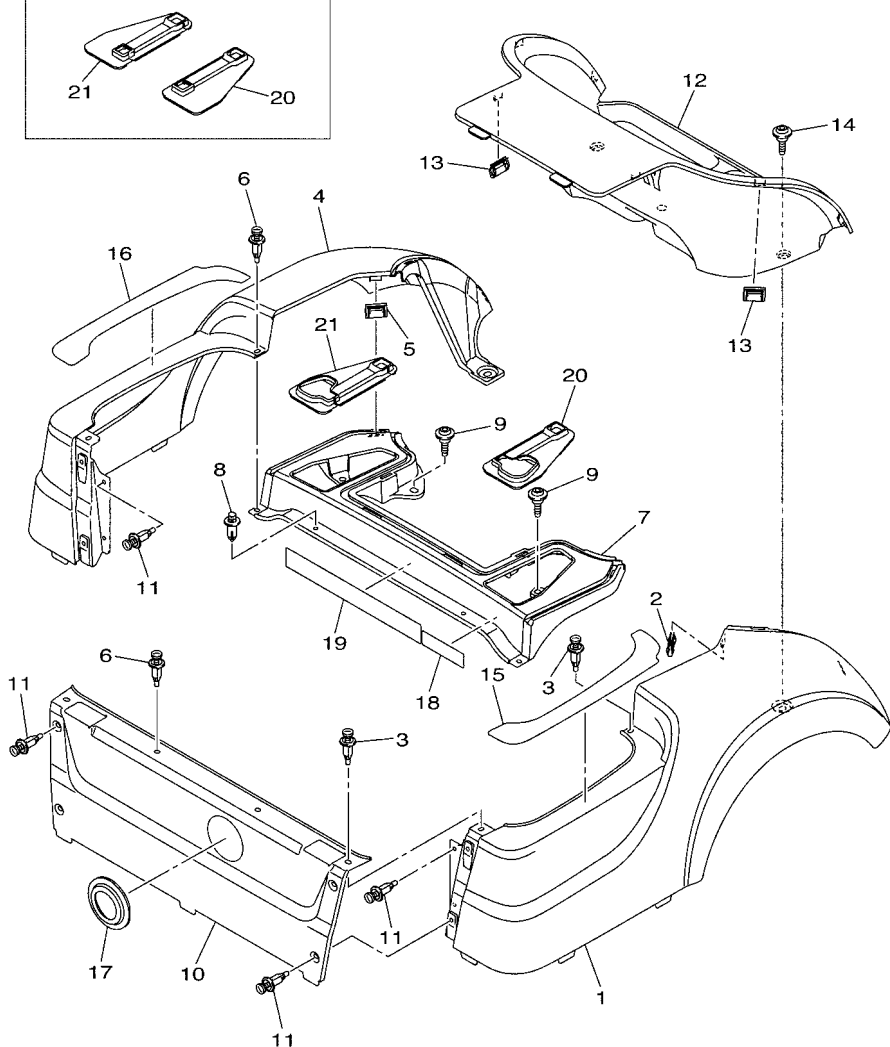
REF. NO.	PART NO.	DESCRIPTION	J0C4	REMARKS
1	J0B-K8115-A0	COWL, FRONT	1	UR FOR BW1
	J0B-K8115-10	COWL, FRONT	1	UR FOR VDGS1
	J0B-K8115-00	COWL, FRONT	1	UR FOR DNBME
	J0B-K8115-30	COWL, FRONT	1	UR FOR LNMP
	J0B-K8115-B0	COWL, FRONT	1	UR FOR NYS4
	J0B-K8115-50	COWL, FRONT	1	UR FOR HTR
	J0B-K8115-60	COWL, FRONT	1	UR FOR DNMC
	J0B-K8115-R0	COWL, FRONT	1	UR FOR MDBM2
	J0B-K8115-S0	COWL, FRONT	1	UR FOR NYM6
2	J0B-F4161-00	EMBLEM 1	1	
3	JU0-K7573-00	NUT, SPECIAL	2	
4	90105-06831	BOLT, FLANGE	1	
5	90269-06804	RIVET	2	
6	J0B-K8114-01	PANEL, FRONT	1	UR FOR CAN
	J0C-K8114-01	PANEL, FRONT	1	UR EXCEPT FOR CAN
7	90269-08001	RIVET	3	
8	J0B-K7768-30	LABEL, WARNING 8	1	UR ENGLISH
	J0B-K7768-40	LABEL, WARNING 8	1	UR ENGLISH/FRENCH
	J0B-K7768-50	LABEL, WARNING 8	1	UR GERMAN
	J0B-K7768-60	LABEL, WARNING 8	1	UR SPANISH
9	J0B-K8282-00	PLATE, SWITCH PANEL	1	
10	J0C-K7741-00	INDICATOR 1	1	
11	J0B-K835E-00	HOLDER, BEVERAGE	1	
12	90111-05805	BOLT, HEX. SOCKET BUTTON	1	
13	90183-05008	NUT, SPRING	1	
14	J0B-H2370-00	PLUG CAP ASSY	1	
15	J0B-K8233-00	MAT, MAIN FLOOR 3	1	



**FIG. 11 BODY**

REF. NO.	PART NO.	DESCRIPTION	J0C4	REMARKS
16	90269-09003	RIVET	12	
17	J0B-K8273-10	COVER, HOLE	1	
18	J0B-K8243-00	MAT, REAR BODY SIDE (LH)	1	
19	90269-07805	RIVET	2	
20	J0B-K8244-00	MAT, REAR BODY SIDE (RH)	1	
21	90269-07805	RIVET	2	
22	J1B-K832F-00	GROMMET, ROOF SUPPORT 1	1	WITH SUN ROOF
	J0B-K832F-00	GROMMET, ROOF SUPPORT 1	1	WITHOUT SUN ROOF
23	J1B-K832G-00	GROMMET, ROOF SUPPORT 2	1	WITH SUN ROOF
	J0B-K832G-00	GROMMET, ROOF SUPPORT 2	1	WITHOUT SUN ROOF

WITHOUT SUN ROOF

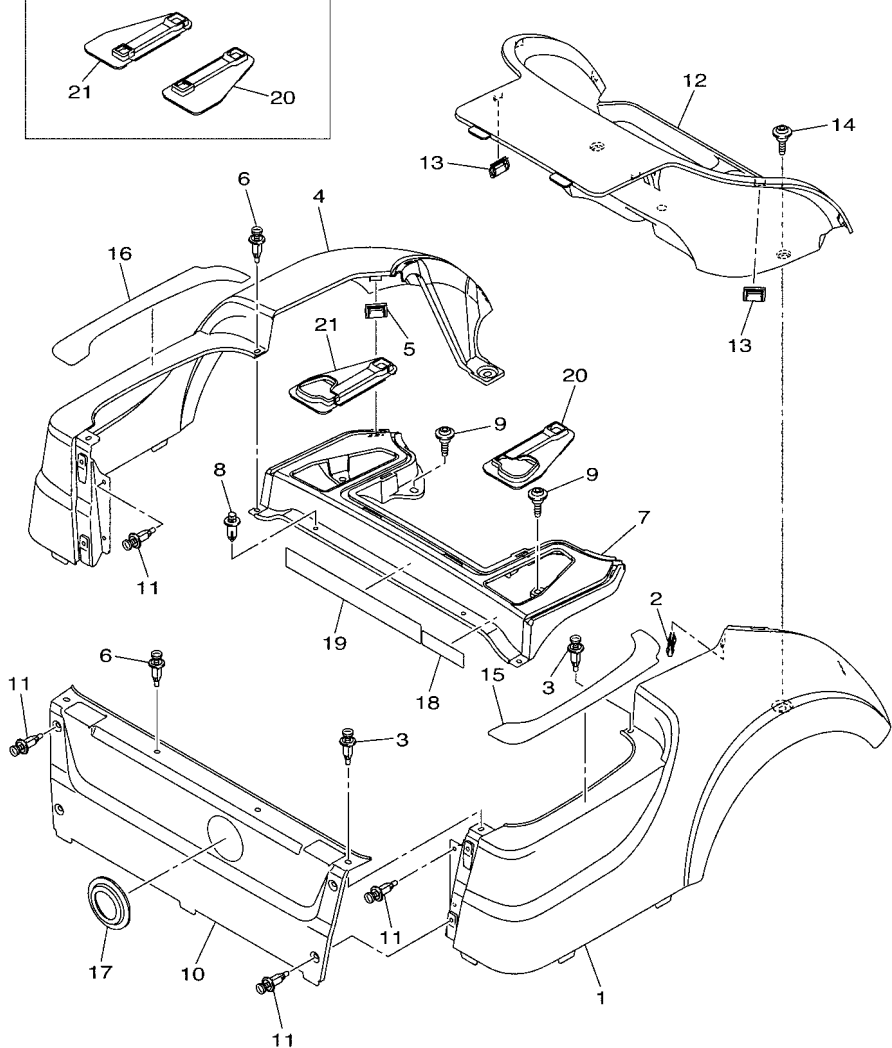


J0C1110-S120

FIG. 12 BODY 2

REF. NO.	PART NO.	DESCRIPTION	J0C4	REMARKS
1	J0B-K8111-A0	PANEL, BODY SHELL	1	UR FOR BW1
	J0B-K8111-10	PANEL, BODY SHELL	1	UR FOR VDGS1
	J0B-K8111-00	PANEL, BODY SHELL	1	UR FOR DNBME
	J0B-K8111-30	PANEL, BODY SHELL	1	UR FOR LNMP
	J0B-K8111-B0	PANEL, BODY SHELL	1	UR FOR NYS4
	J0B-K8111-50	PANEL, BODY SHELL	1	UR FOR HTR
	J0B-K8111-60	PANEL, BODY SHELL	1	UR FOR DNMC
	J0B-K8111-R0	PANEL, BODY SHELL	1	UR FOR MDBM2
	J0B-K8111-S0	PANEL, BODY SHELL	1	UR FOR NYM6
2	J0B-F3447-00	CLIP	1	
3	90269-07805	RIVET	3	
4	J0B-K8112-A0	PANEL, BODY SHELL	1	UR FOR BW1
	J0B-K8112-10	PANEL, BODY SHELL	1	UR FOR VDGS1
	J0B-K8112-00	PANEL, BODY SHELL	1	UR FOR DNBME
	J0B-K8112-30	PANEL, BODY SHELL	1	UR FOR LNMP
	J0B-K8112-B0	PANEL, BODY SHELL	1	UR FOR NYS4
	J0B-K8112-50	PANEL, BODY SHELL	1	UR FOR HTR
	J0B-K8112-60	PANEL, BODY SHELL	1	UR FOR DNMC
	J0B-K8112-R0	PANEL, BODY SHELL	1	UR FOR MDBM2
	J0B-K8112-S0	PANEL, BODY SHELL	1	UR FOR NYM6
5	J0B-F3447-00	CLIP	1	
6	90269-07805	RIVET	3	
7	J0B-K819H-00	SHELL, REAR BODY	1	
8	JW7-K7329-00	RIVET	2	
9	J0B-F1738-00	BOLT	4	
10	J0C-K8141-A0	PANEL, INTERMEDIATE BODY	1	UR FOR BW1
	J0C-K8141-10	PANEL, INTERMEDIATE BODY	1	UR FOR VDGS1

WITHOUT SUN ROOF



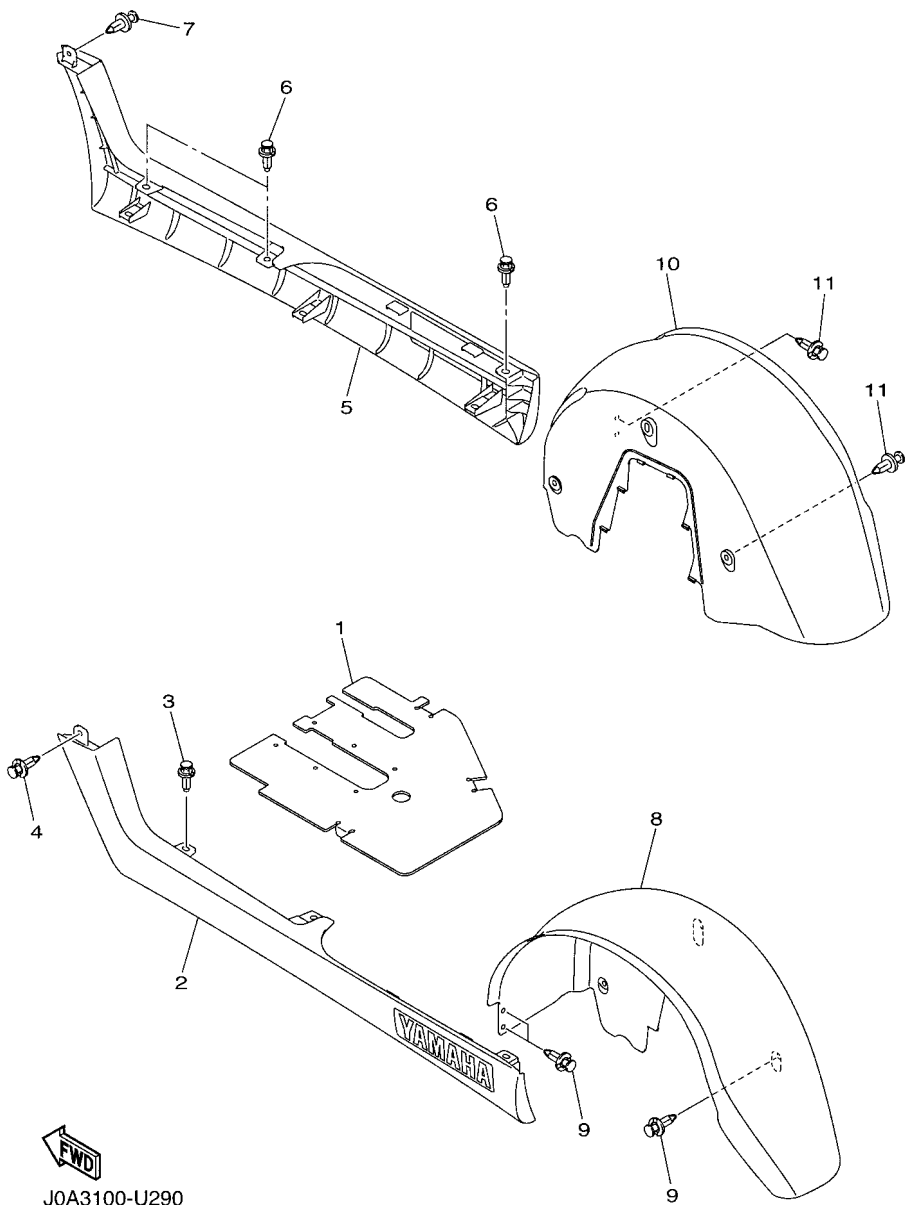
J0C1110-S120

FIG. 12 BODY 2

REF. NO.	PART NO.	DESCRIPTION	J0C4	REMARKS
10	J0C-K8141-00	PANEL, INTERMEDIATE BODY	1	UR FOR DNBME
	J0C-K8141-30	PANEL, INTERMEDIATE BODY	1	UR FOR LNMP
	J0C-K8141-B0	PANEL, INTERMEDIATE BODY	1	UR FOR NYS4
	J0C-K8141-50	PANEL, INTERMEDIATE BODY	1	UR FOR HTR
	J0C-K8141-60	PANEL, INTERMEDIATE BODY	1	UR FOR DNMC
	J0C-K8141-R0	PANEL, INTERMEDIATE BODY	1	UR FOR MDBM2
	J0C-K8141-S0	PANEL, INTERMEDIATE BODY	1	UR FOR NYM6
11	90269-07805	RIVET	8	
12	J0B-K8237-02	COVER, REAR FLOOR	1	FOR 2 BAGS
13	J0B-F3447-00	CLIP	4	
14	J0B-F1738-00	BOLT	2	
15	J0B-F2873-01	SEAL 1	1	
16	J0B-F2874-01	SEAL 2	1	
17	J0C-K827A-00	GUIDE 1	1	
18	J0C-K8298-00	PLATE, CAUTION 2	1	UR ENGLISH/FRENCH
	J0C-K8298-10	PLATE, CAUTION 2	1	UR GERMAN/SPANISH
19	JW9-K8297-01	PLATE, CAUTION 1	1	UR ENGLISH/FRENCH
	JW9-K8297-11	PLATE, CAUTION 1	1	UR GERMAN/SPANISH
20	J0B-K817H-10	TRIM, SIDE PANEL 1	1	WITH SUN ROOF
	J0B-K817H-00	TRIM, SIDE PANEL 1	1	WITHOUT SUN ROOF
21	J0B-K817J-10	TRIM, SIDE PANEL 2	1	WITH SUN ROOF
	J0B-K817J-00	TRIM, SIDE PANEL 2	1	WITHOUT SUN ROOF

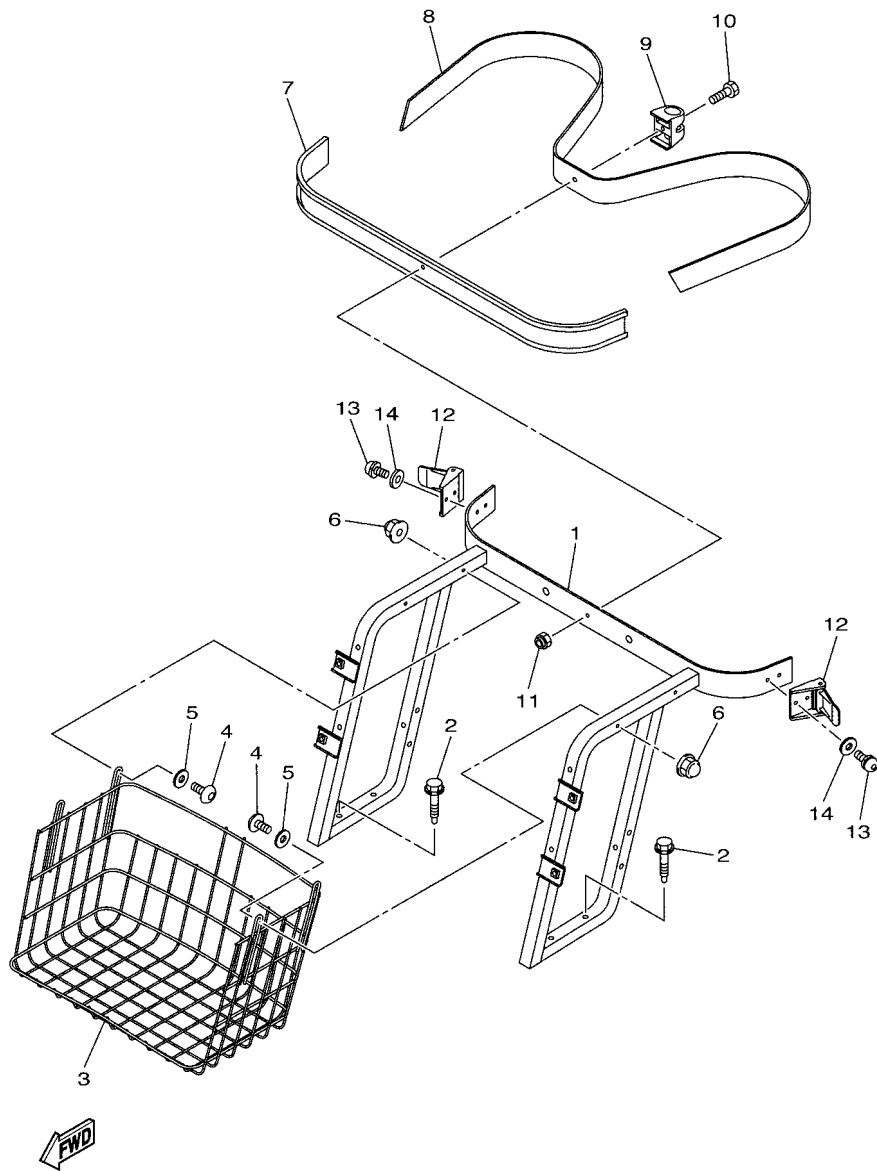


**FIG. 13 BODY FITTING**



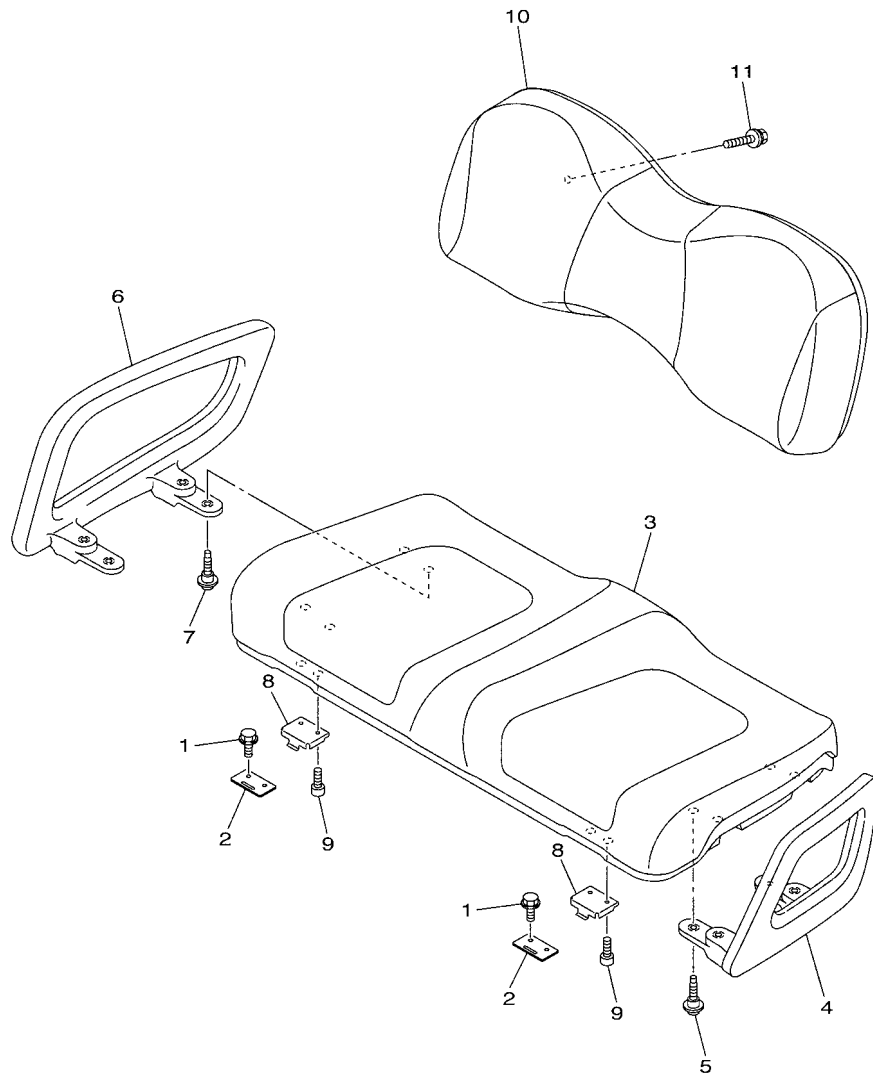
REF. NO.	PART NO.	DESCRIPTION	J0C4	REMARKS
1	J0B-K8271-01	SERVICE LID, PEDAL	1	
2	J0B-K818A-00	PROTECTOR, SIDE PLATE	1	
3	90269-09003	RIVET	3	
4	90269-06804	RIVET	1	
5	J0B-K818B-00	PROTECTOR, SIDE PLATE 2	1	
6	90269-09003	RIVET	3	
7	90269-06804	RIVET	1	
8	J0B-K8191-00	PANEL, REAR FENDER 1	1	
9	90269-06804	RIVET	5	
10	J0B-K8192-00	PANEL, REAR FENDER 2	1	
11	90269-06804	RIVET	5	

**FIG. 14 CARRIER**



J0B1110-S280

REF. NO.	PART NO.	DESCRIPTION	J0C4				REMARKS
1	J0B-K8423-00	SUPPORT, SEAT BACK	1				
2	90109-08178	BOLT	4				
3	JW1-K8340-00	LUGGAGE RACK ASSY., REAR	1				
4	92017-06040	BOLT, BUTTON HEAD	4				
5	J0B-K7389-00	WASHER	4				
6	90176-06008	NUT, CROWN	4				
7	JF2-K8356-00	PAD, BAG SUPPORT	1				
8	JN6-K8355-20	BAND	1				
9	JW1-K834G-00	HOLDER, RAKE SAND	1				
10	9708R-06020	BOLT	1				
11	90185-06836	NUT, SELF-LOCKING	1				
12	JN6-K8380-00	LOCK ASSY	2				
13	90159-06845	SCREW, WITH WASHER	4				
14	9299R-06200	WASHER	4				



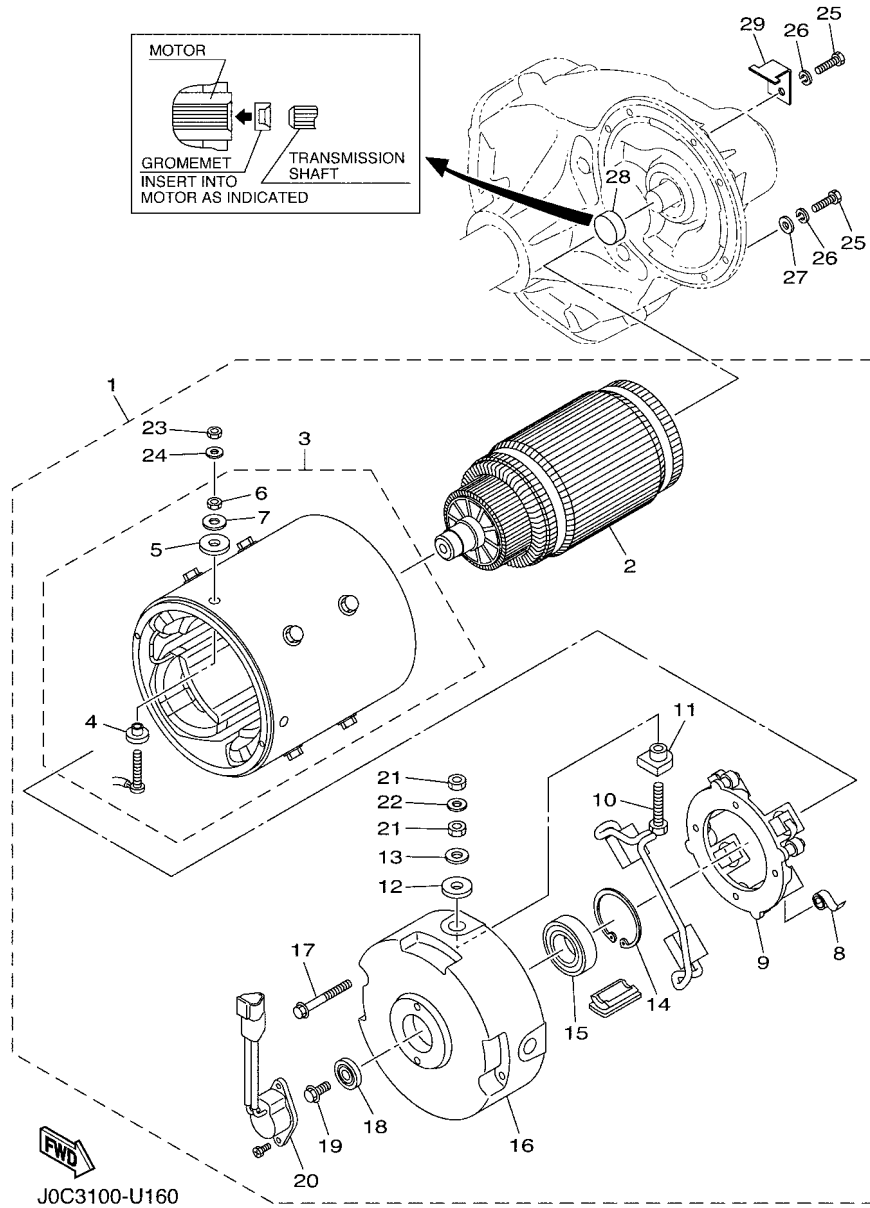
**FIG. 15 SEAT**

REF. NO.	PART NO.	DESCRIPTION	JOC4				REMARKS
1	JW9-H1674-00	BOLT	4				
2	JW1-K8427-00	HINGE, SEAT 2	2				
3	J0A-K8401-10	SEAT SUB-ASSY,CUSHION	1				
4	J0B-K8361-00	ARM REST 1	1				
5	J0B-F1738-00	BOLT	4				
6	J0B-K8362-00	ARM REST 2	1				
7	J0B-F1738-00	BOLT	4				
8	J0B-K8426-01	HINGE, SEAT 1	2				
9	90110-06125	BOLT, HEXAGON SOCKET HEAD	4				
10	JW1-K8402-10	SEAT SUB ASSY, BACK	1				
11	90119-06808	BOLT, WITH WASHER	4				



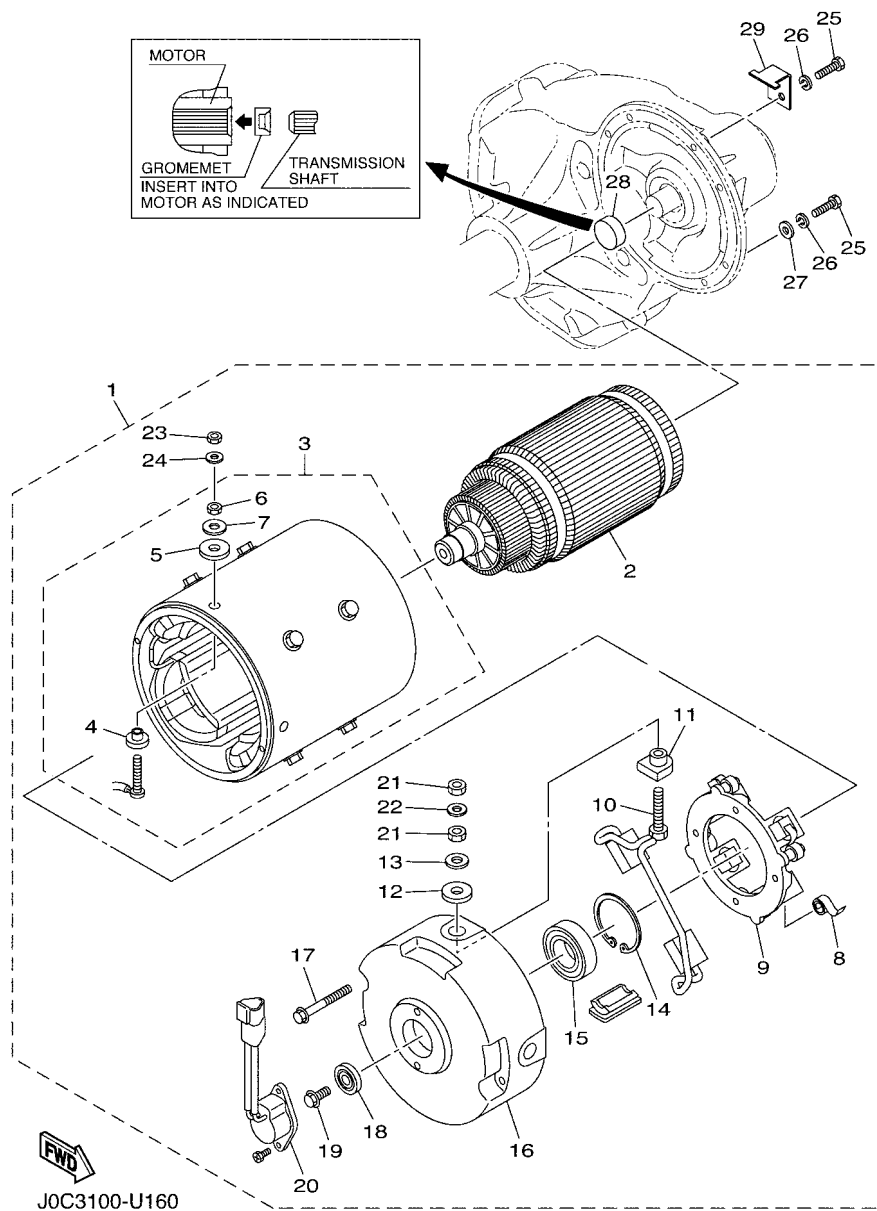
J0B1110-S290

**FIG. 16 ELECTRIC MOTOR**



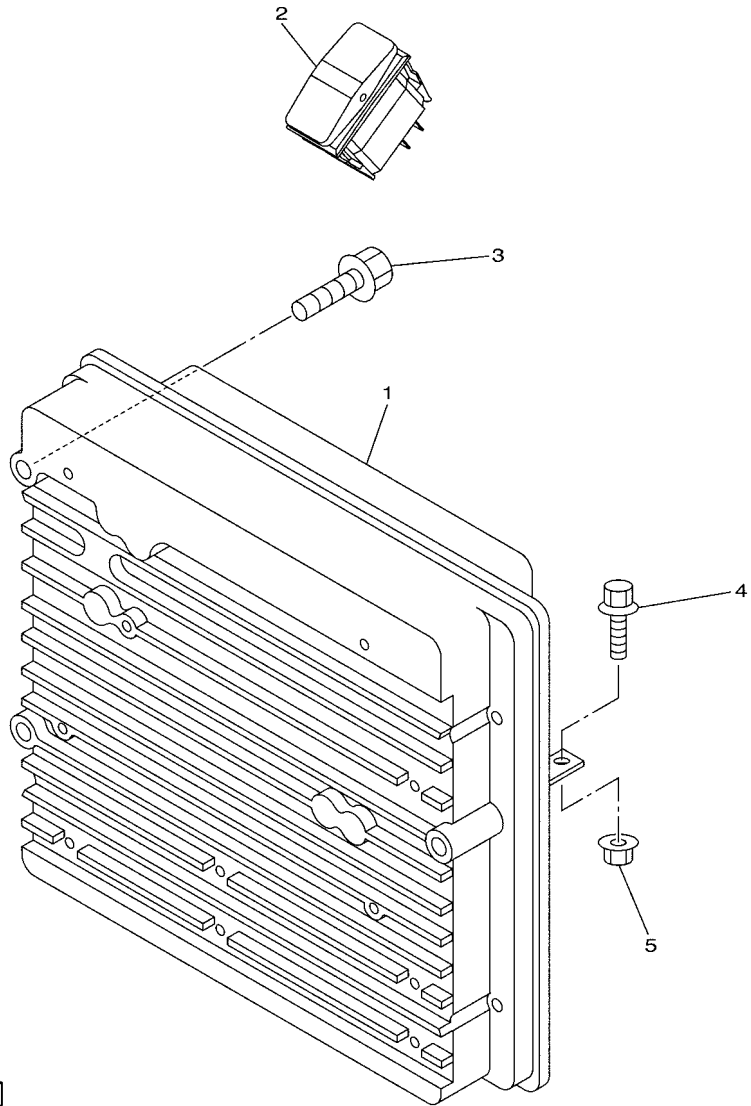
REF. NO.	PART NO.	DESCRIPTION	J0C4	REMARKS
1	J0C-H1890-01	MOTOR ASSY	1	
2	J0C-H1850-00	.ARMATURE ASSY	1	
3	J0C-H1160-00	.FIELD COIL ASSY	1	
4	J0C-H272L-00	.INSULATOR, 1	2	
5	J0C-H272N-00	.PLATE, INSULATOR	2	
6	J0C-H182A-00	.NUT	2	
7	J0C-H3348-00	.WASHER	2	
8	J0C-H1617-00	.SPRING, BRUSH	4	
9	J0C-H1840-00	.BRUSH HOLDER ASSY	1	
10	J0C-H1801-00	.BRUSH SET	2	
11	J0C-H182G-00	.BUSH, TERMINAL	2	
12	J0C-H1843-00	.WASHER 1	2	
13	J0C-H181L-00	.WASHER, PLAIN	2	
14	J0C-H1856-00	.RETAINER	1	
15	J0C-H185B-00	.BEARING 1	1	
16	J0C-H183J-00	.BRACKET, FRONT	1	
17	J0C-H1828-00	.BOLT 2	2	
18	J0C-H181K-00	.MAGNET	1	
19	J0C-H2113-00	.SCREW	1	
20	J0C-H1670-00	.PICK-UP ASSY	1	
21	J0C-H1872-00	.NUT, SPECIAL	4	
22	J0C-H1835-00	.WASHER	2	
23	J0C-H182A-00	.NUT	2	
24	J0C-H185A-00	.WASHER, PLATE	2	
25	90101-069U0	BOLT	3	
26	90215-06811	WASHER, LOCK	3	
27	90201-068E2	WASHER, PLATE	2	

FIG. 16 ELECTRIC MOTOR



REF. NO.	PART NO.	DESCRIPTION	JOC4				REMARKS
28	JH7-H1829-00	GROMMET	1				
29	JU2-H218E-01	RELIEF, STRAIN 1	1				

**FIG. 17 CONTROLLER 1**



J0C3100-U170

REF. NO.	PART NO.	DESCRIPTION	J0C4	REMARKS
1	JW2-H6510-30	MOTOR CONTROL UNIT ASSY	1	
2	JW2-H2727-00	SWITCH	1	
3	JW9-H1674-00	BOLT	3	
4	95822-06016	BOLT, FLANGE	3	
5	95602-06200	NUT, SELF-LOCKING	3	
<hr/>				
<hr/>				
<hr/>				
<hr/>				
<hr/>				
<hr/>				
<hr/>				
<hr/>				
<hr/>				
<hr/>				
<hr/>				

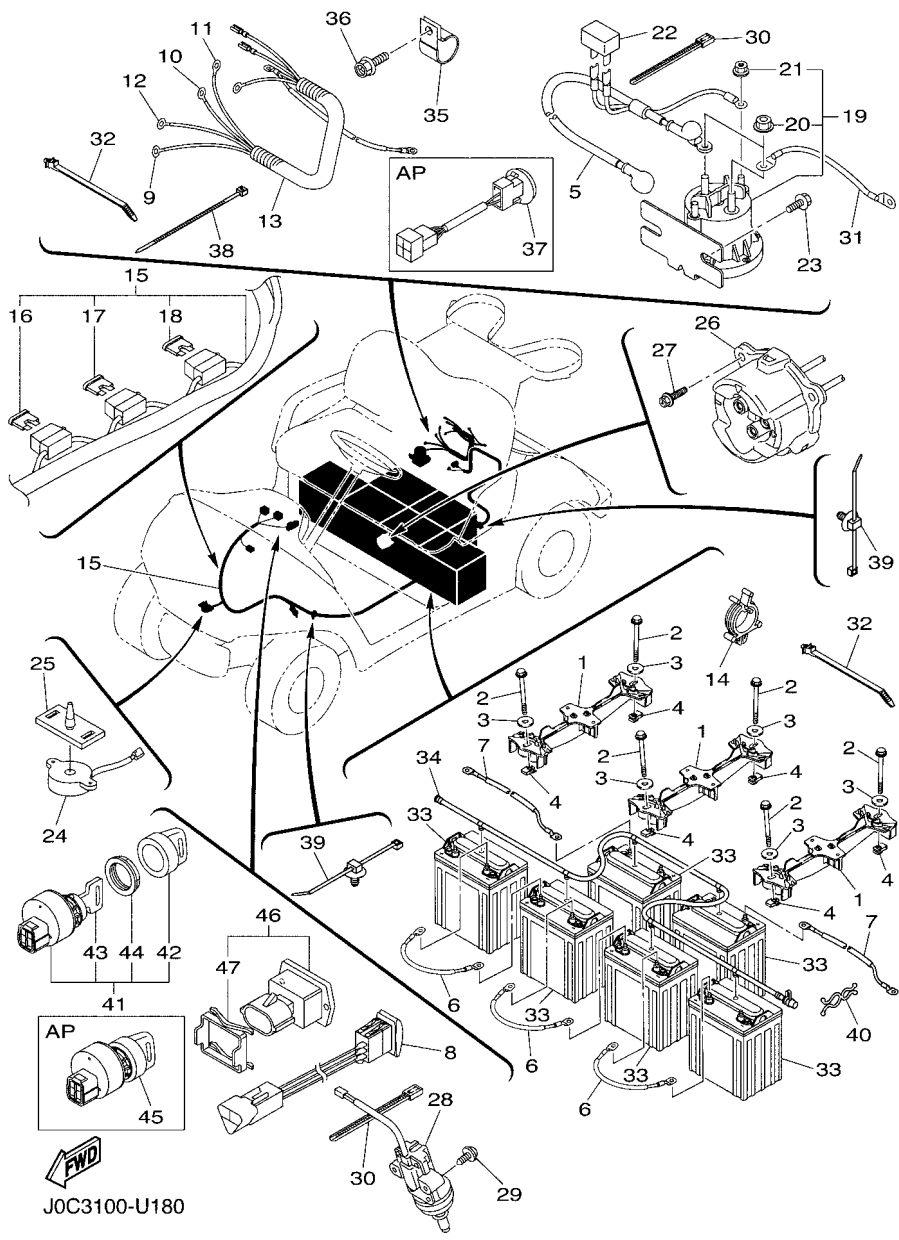


FIG. 18 ELECTRICAL 1

REF. NO.	PART NO.	DESCRIPTION	J0C4	REMARKS
1	JW9-H2136-00	PLATE, BATTERY FITTING	3	
2	JW9-H1892-00	BOLT, SPECIAL	6	
3	90201-08310	WASHER, PLATE	6	
4	JW9-K811K-00	NUT, TRIM FITTING	6	
5	JW9-H2115-20	WIRE, PLUS LEAD	1	
6	JW9-H2127-00	WIRE, LEAD 2	3	
7	JW9-H2149-00	WIRE, LEAD 3	2	
8	JU2-H2917-00	SWITCH	1	
9	JU2-H2521-20	WIRE, LEAD	1	(S1)
10	JU2-H2531-20	WIRE, LEAD	1	(S2)
11	JU2-H6171-20	WIRE, LEAD 1	1	(A1)
12	JW9-H6172-00	WIRE, LEAD 2	1	(A2)
13	JU2-H7196-20	TUBE 1	1	
14	90464-25826	CLAMP	2	
15	J0C-H2590-21	WIRE HARNESS ASSY	1	UR FOR CAN
	J0C-H2590-31	WIRE HARNESS ASSY	1	UR EXCEPT FOR CAN
16	J0C-H2151-00	.FUSE (5A)	1	
17	JR1-H2151-00	.FUSE (3A)	1	
18	J0E-H2151-10	.FUSE (1A)	1	
19	JW9-H1950-20	RELAY ASSY	1	
20	90179-05807	.NUT	2	
21	90179-08824	.NUT	2	
22	JW9-85371-00	RESISTOR COMP.	1	
23	90105-06831	BOLT, FLANGE	2	
24	JR1-H3383-02	BUZZER	1	
25	JN6-H3386-01	STAY, BUZZER	1	
26	JW9-H6181-00	RECEPTACLE	1	

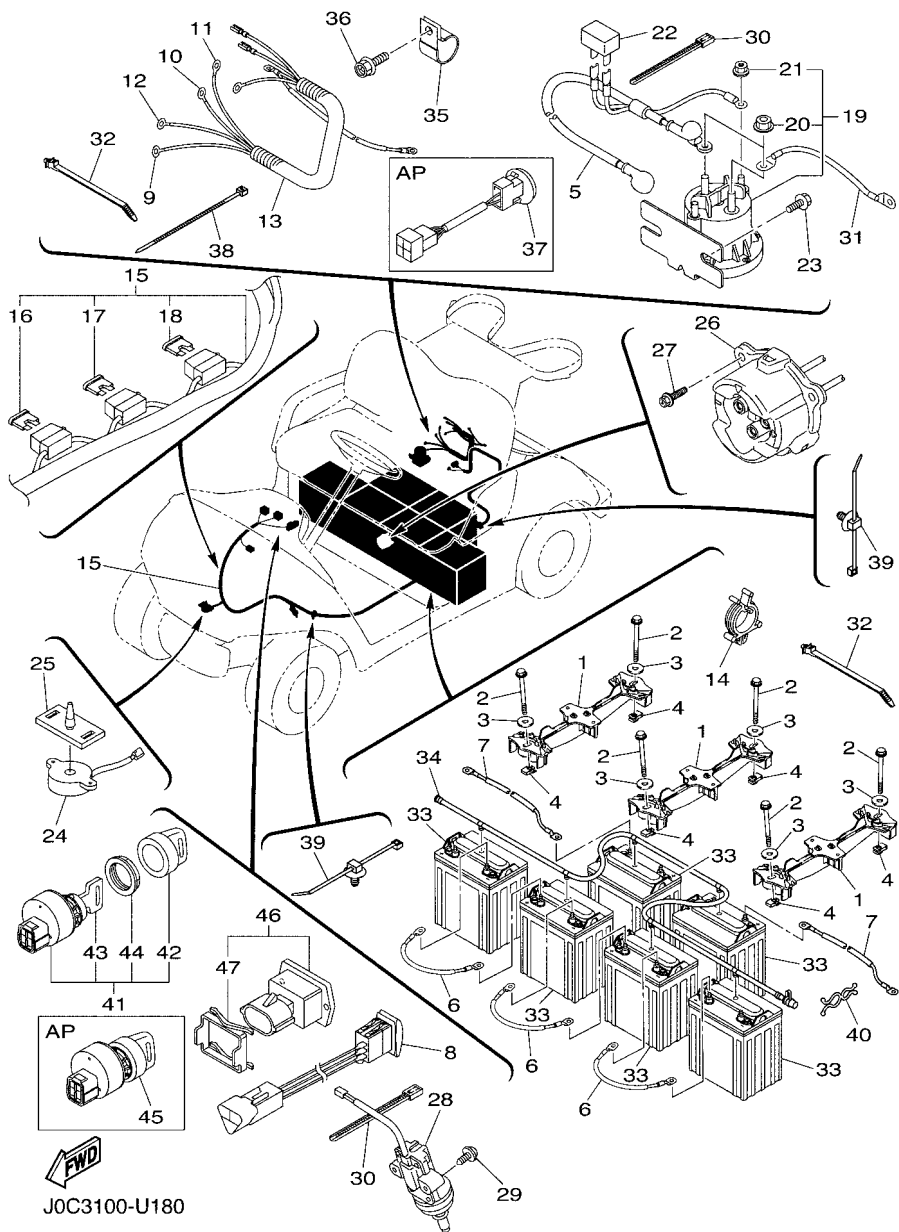
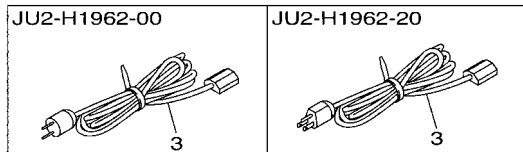
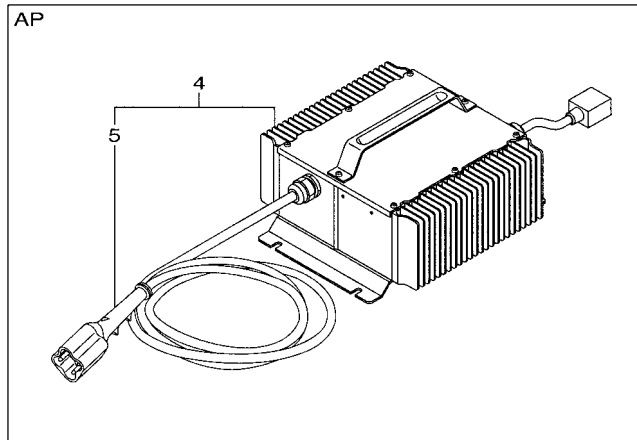
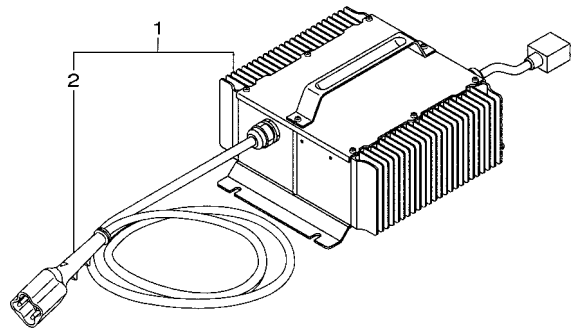


FIG. 18 ELECTRICAL 1

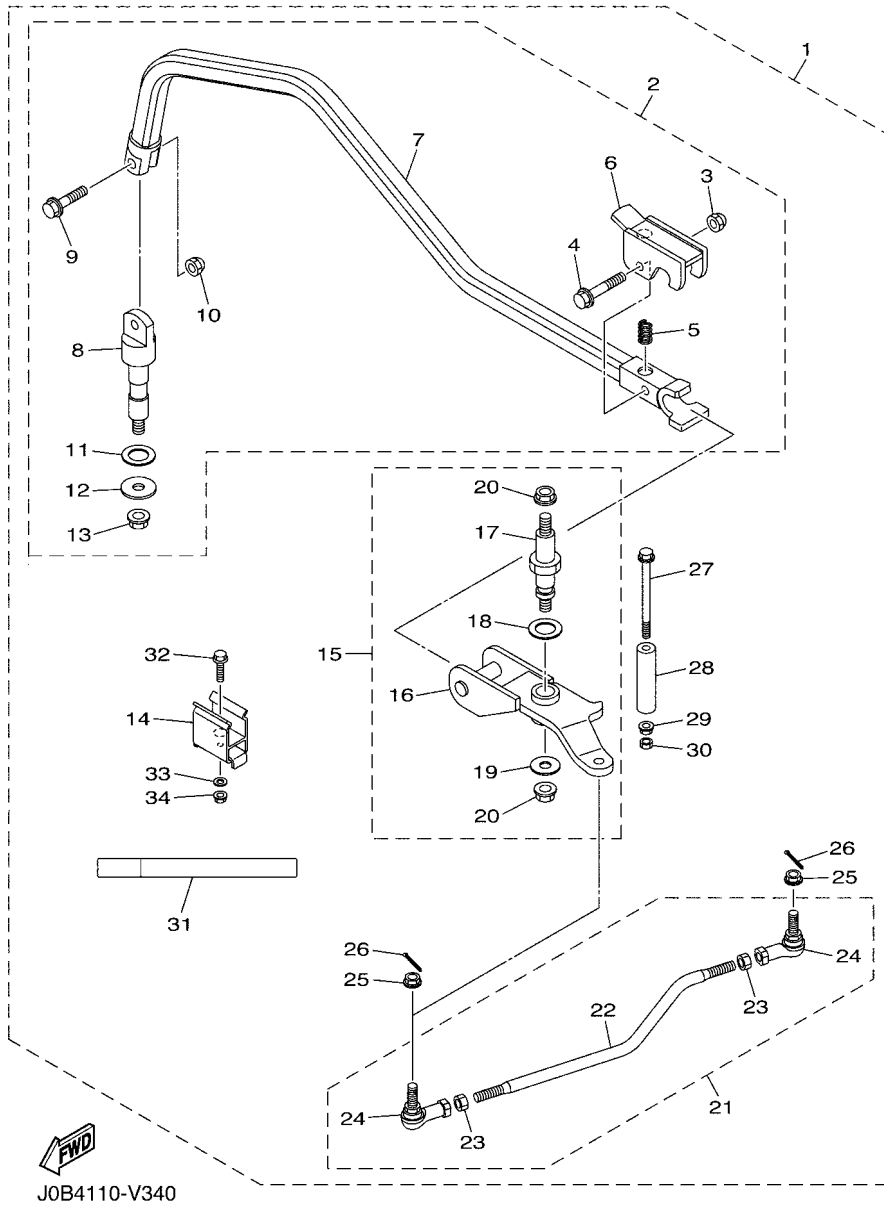
REF. NO.	PART NO.	DESCRIPTION	JOC4	REMARKS
27	JW1-F3394-00	BOLT, SPECIAL	3	
28	JF7-82817-22	SWITCH	1	
29	97602-05225	SCREW, PAN HEAD WITH WASHER	2	
30	90464-40825	CLAMP	3	
31	JW2-H6527-00	WIRE 7	1	
32	90464-20005	CLAMP	7	
33	*	BATTERY ASSY (8V, GC8)	6	LM
34	JW9-H210G-00	BATTERY WATERING SYSTEM ASSY.	1	
35	90461-14108	CLAMP	1	
36	90105-08867	BOLT, FLANGE	1	
37	JU2-HA2F0-00	TRANSMITTER UNIT	1	AP
38	90464-48800	CLAMP	1	
39	1NS-F1338-00	CLAMP	2	
40	90464-14134	CLAMP	1	
41	JW1-H2510-00	MAIN SWITCH ASSY	1	STD
42	5UG-H2579-00	.CAP, KEY	1	
43	JU2-H2511-00	.KEY, MAIN SWITCH	2	
44	JU6-H2569-00	.NUT, MAIN SWITCH	1	
45	JU2-H2510-20	MAIN SWITCH ASSY	1	AP RANDOMKEY
46	JW2-H351B-01	GAUGE, BATTERY	1	EXCEPT FOR CAN
47	JW1-H1128-00	.CLAMP	1	EXCEPT FOR CAN



**FIG. 19 BATTERY CHARGER**



REF. NO.	PART NO.	DESCRIPTION	JOC4				REMARKS
1	JW2-H2107-51	CHARGER, BATTERY	1				
2	JW2-H7209-20	.CHARGE CORD ASSY	1				
3	JU2-H1962-00	CORD COMP. (220V)	1				UR
	JU2-H1962-20	CORD COMP. (100V)	1				UR
4	JW2-H2107-A1	CHARGER, BATTERY	1				AP
5	JW2-H7209-A0	.CHARGE CORD ASSY	1				



J0B4110-V340

FIG. 20 ALTERNATE FOR CHASSIS

REF. NO.	PART NO.	DESCRIPTION	J0C4	REMARKS
1	J0B-F722B-A3	BAR, TOW	1	AP
2	J0B-F389J-A0	.DRAW BAR ASSY	1	
3	J0B-F4681-00	..NUT, CAP	1	
4	95802-10050	..BOLT, FLANGE	1	
5	J0B-F178D-A0	..SPRING, HOOK	1	
6	J0B-F381J-A0	..BAR, HANDLE	1	
7	J0B-F7224-00	..BAR, PEDAL LINK	1	
8	J0B-F2141-00	..SHAFT, PIVOT	1	
9	95802-10035	..BOLT, FLANGE	1	
10	J0B-F4681-00	..NUT, CAP	1	
11	J0B-F3418-00	..WASHER, SPECIAL	1	
12	90201-128S4	..WASHER, PLATE	1	
13	95602-12200	..NUT, SELF-LOCKING	1	
14	J0B-F5522-00	.HOLDER	1	
15	J0B-F389K-A1	.ARM PIVOT ASSY	1	
16	J0B-F389G-00	..ARM, PIVOT	1	
17	J0B-F3849-A0	..SHAFT 1	1	
18	90201-208S8	..WASHER, PLATE	1	
19	J0B-F3392-00	..WASHER, SPECIAL	1	
20	95602-12200	..NUT, SELF-LOCKING	2	
21	J0B-F3880-A0	.TIE ROD ASSEMBLY 3	1	
22	J0B-F383A-00	..TIE ROD ASSEMBLY 3	1	
23	95302-10600	..NUT, HEXAGON	2	
24	J0B-F3841-A0	..JOINT, UNIVERSAL 1	2	
25	95602-10200	..NUT, S/L FLANGE	2	
26	91402-25020	..PIN, COTTER	2	
27	90105-088A9	..BOLT, FLANGE	1	

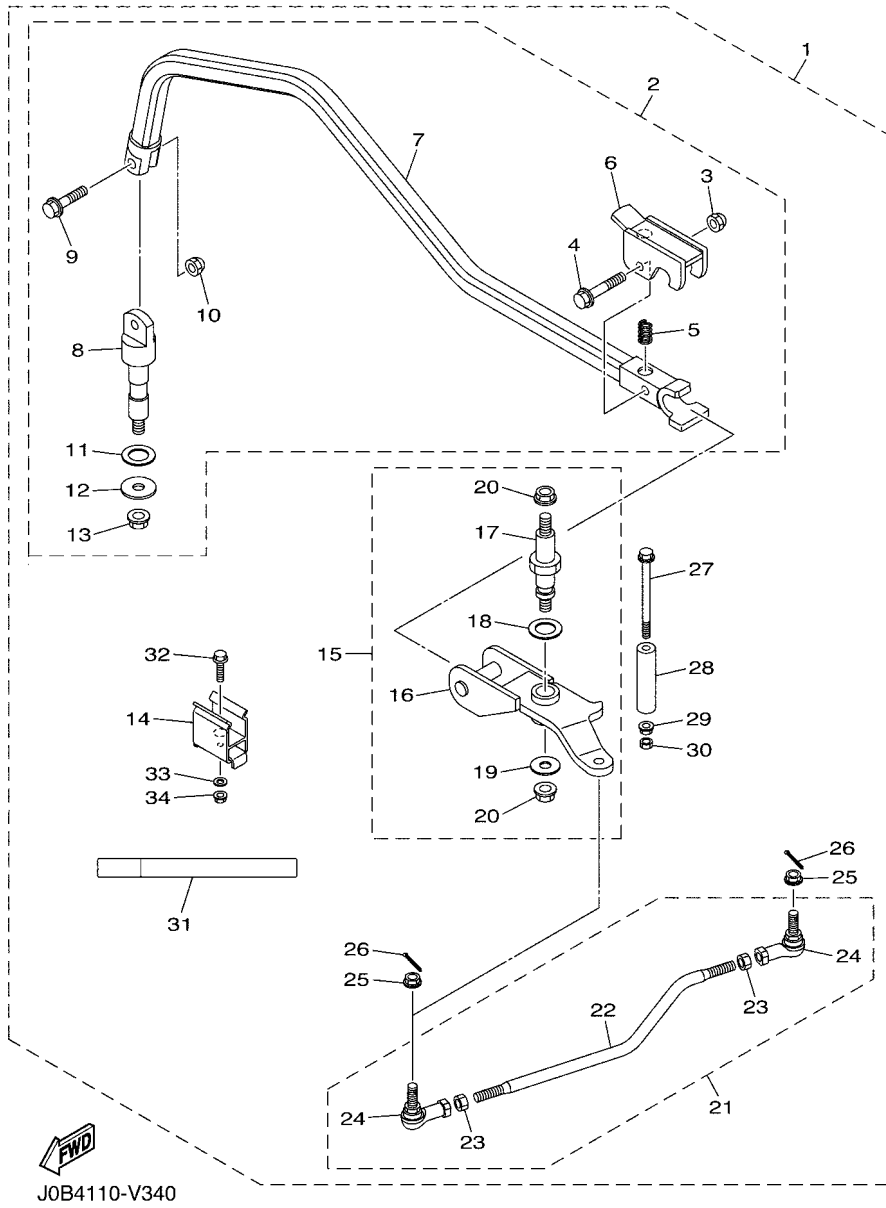
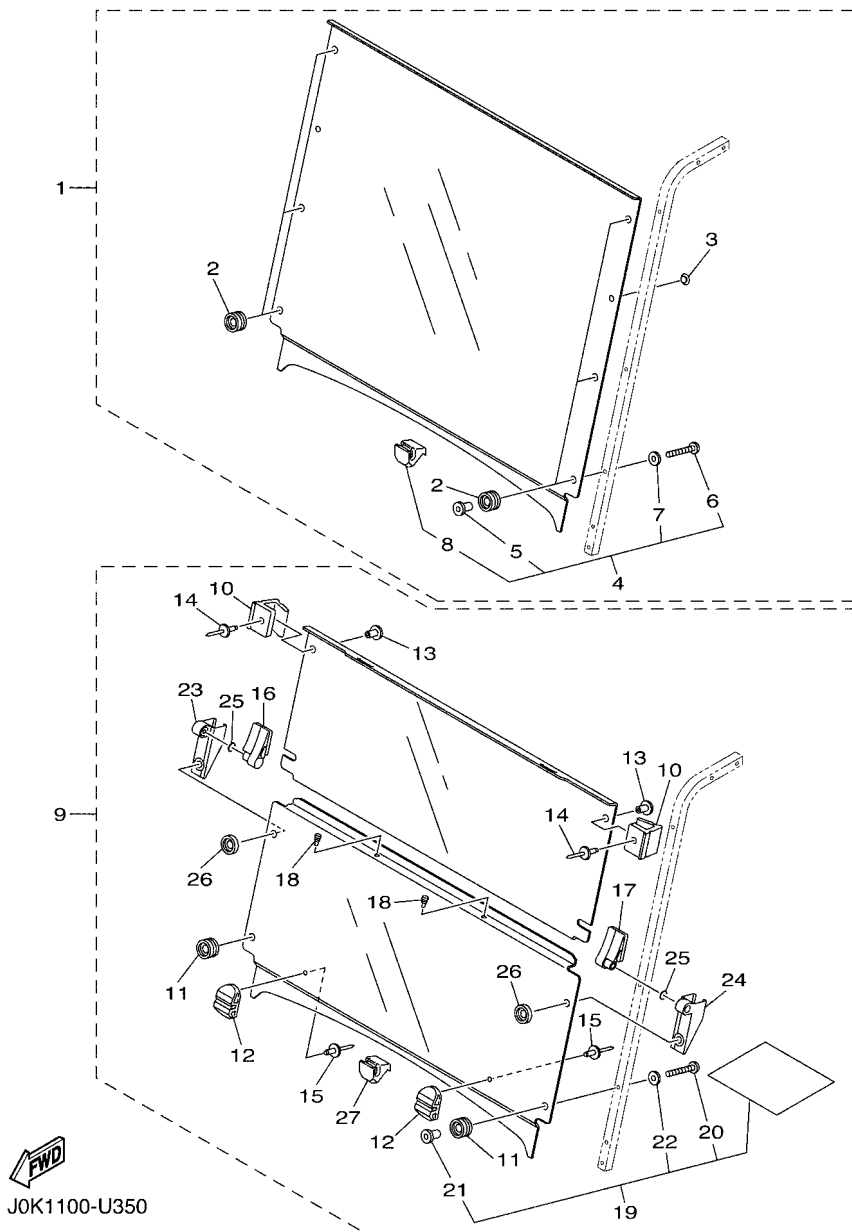


FIG. 20 ALTERNATE FOR CHASSIS

REF. NO.	PART NO.	DESCRIPTION	J0C4				REMARKS
28	J0B-F3432-00	.STOPPER, STEERING 1	1				
29	95602-08200	.NUT, U FLANGE	1				
30	95602-08100	.NUT, U	1				
31	J0B-K7761-A0	.LABEL, WARNING 1	1				
32	95812-06025	.BOLT, FLANGE	1				
33	90201-06102	.WASHER, PLATE	1				
34	95602-06200	.NUT, SELF-LOCKING	1				

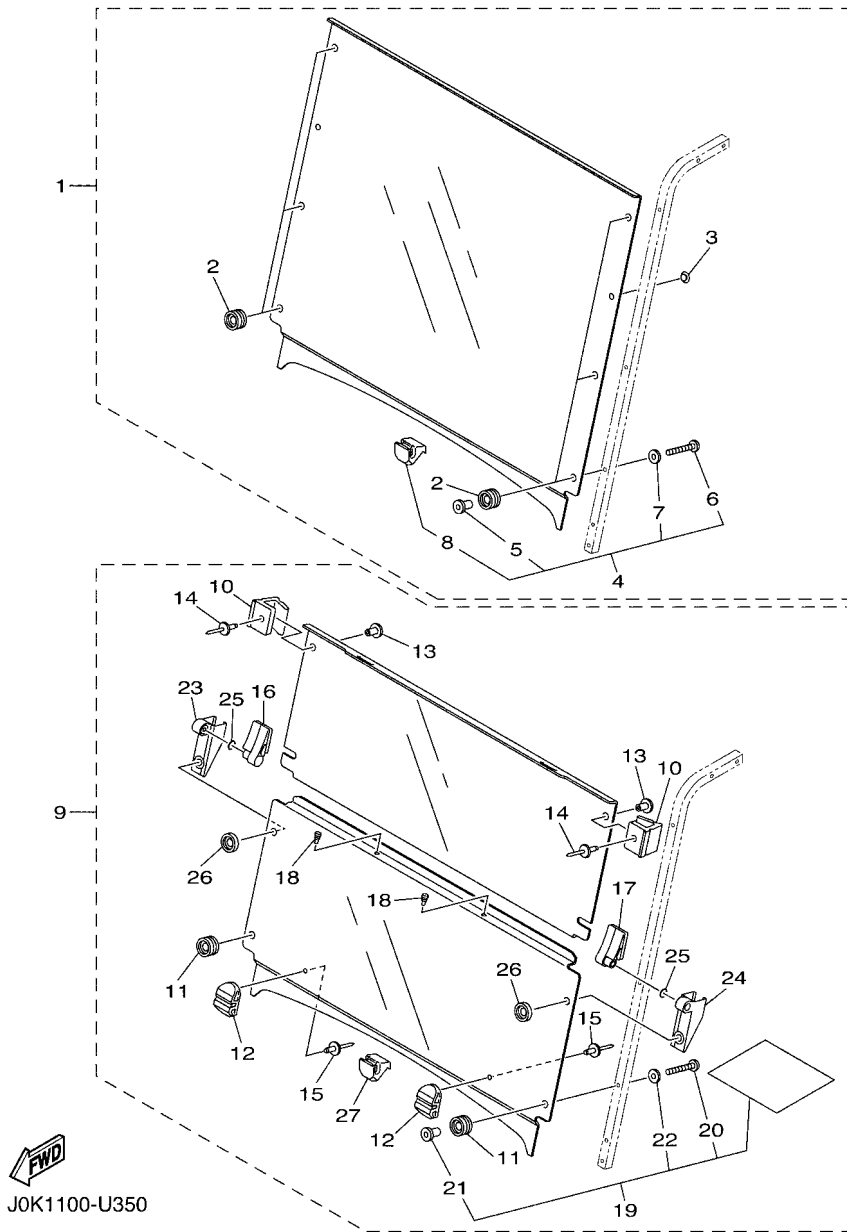
**FIG. 21 ALTERNATE FOR WINDSHIELD**



J0K1100-U350

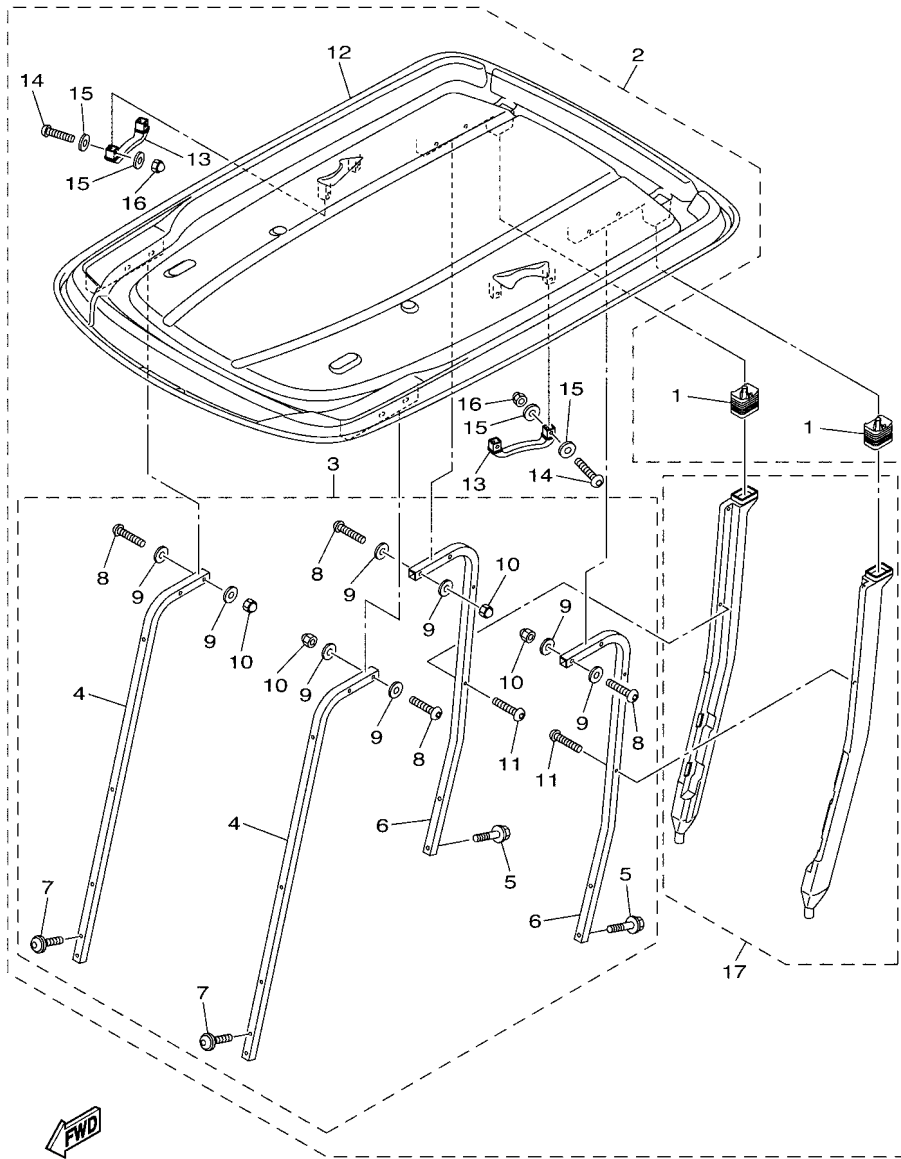
REF. NO.	PART NO.	DESCRIPTION	JOC4	REMARKS
1	J0B-K7200-01	WINDSHIELD ASSY	1	UR AP CLEAR
	J0B-K7200-11	WINDSHIELD ASSY	1	UR AP SMOKE
2	J0B-K7237-00	.GROMMET	6	
3	J0B-K7238-00	.DAMPER	2	
4	J0B-K7240-01	.WIND SHIELD HARDWARE KIT 1	1	
5	J0B-K7217-00	..NUT, WIND SHIELD	6	
6	J0B-K7248-00	..SCREW 1	6	
7	J0B-K7218-00	..WASHER 1	6	
8	J0B-K838A-20	..RETAINER 1	1	
9	J0B-K7200-24	WINDSHIELD ASSY	1	UR AP CLEAR
	J0B-K7200-34	WINDSHIELD ASSY	1	UR AP SMOKE
10	J0B-K7173-21	..LEVER, LATCH 1	2	
11	J0B-K7237-00	.GROMMET	2	
12	J0B-K7257-20	.GROMMET, W/S 3	2	
13	J0G-K7155-C0	.RIVET 1	2	
14	J0G-K7156-C0	.RIVET 2	2	
15	J0B-K7155-20	.RIVET 1	2	
16	J0B-K7145-20	.HINGE 1	1	
17	J0B-K7146-20	.HINGE 2	1	
18	J0B-K7529-20	.SPACER, BUMPER	2	
19	J0B-K7240-20	.WIND SHIELD HARDWARE KIT 1	1	
20	J0B-K7248-00	..SCREW 1	4	
21	J0B-K7217-00	..NUT, WIND SHIELD	4	
22	J0B-K7218-00	..WASHER 1	4	
23	J0B-K7147-20	.HINGE 3	1	
24	J0B-K7148-20	.HINGE 4	1	
25	J0B-F3147-20	.O-RING	2	

FIG. 21 ALTERNATE FOR WINDSHIELD



J0K1100-U350

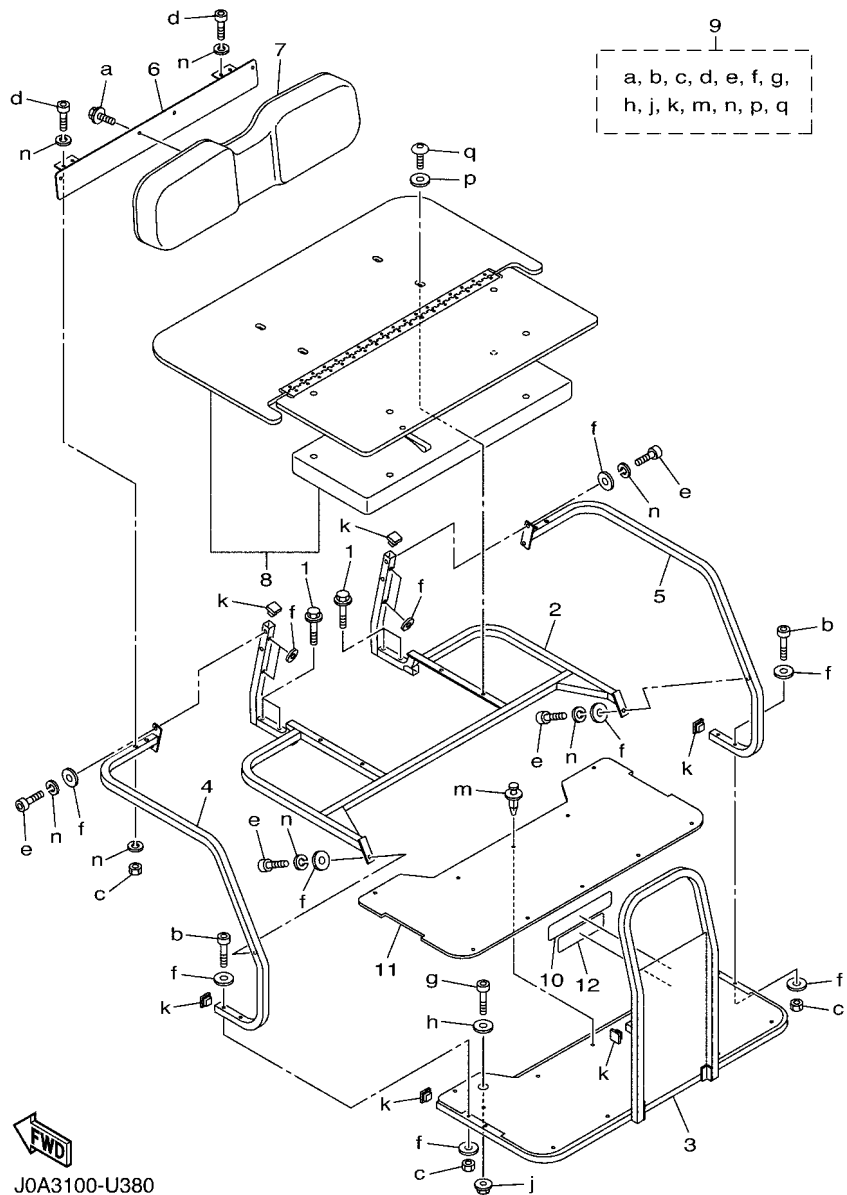
REF. NO.	PART NO.	DESCRIPTION	J0C4				REMARKS
26	J0B-K7247-00	.GROMMET, W/S 2	2				
27	J0B-K838A-20	.RETAINER 1	1				



J0A2100-T370

FIG. 22 ALTERNATE FOR SUN ROOF

REF. NO.	PART NO.	DESCRIPTION	JOC4	REMARKS
1	JW1-F414G-10	SEAL	2	
2	J0B-K84A0-00	SUN TOP KIT	1	UR AP TAN
	J0B-K84A0-10	SUN TOP KIT	1	UR AP BLACK
3	J0B-K84A2-00	.HARDWARE KIT, SUN TOP	1	
4	J0B-K8312-00	..SUPPORT, SUN ROOF 1	2	
5	JW1-K8388-00	..BOLT, ROOF 1	4	
6	JW1-K8313-01	..SUPPORT, SUN ROOF 2	2	
7	J0B-K8388-00	..BOLT, ROOF 1	4	
8	JU0-K8388-00	..BOLT, ROOF 1	8	
9	JW1-F1549-01	..WASHER, FENDER MOLD	16	
10	JU0-K8398-00	..NUT, ROOF 1	8	
11	JW1-K7387-00	..SCREW	4	
12	JW1-K8314-10	..COVER, SUN ROOF	1	UR TAN
	JW1-K8314-21	..COVER, SUN ROOF	1	UR BLACK
13	JW1-K8214-00	..GRIP, HAND	2	
14	JU0-K8388-00	..BOLT, ROOF 1	4	
15	JW1-F1549-01	..WASHER, FENDER MOLD	8	
16	JU0-K8398-00	..NUT, ROOF 1	4	
17	J0B-F417A-00	..DRAIN TUBE ASSY	1	



**FIG. 23 ALTERNATE FOR SEAT**

REF. NO.	PART NO.	DESCRIPTION	JOC4				REMARKS
1	90109-08178	BOLT	4				
2	J0B-K8460-00	SEAT FRAME COMP.	1				
3	J0B-K8477-00	FLOOR ASSEMBLY	1				
4	J0B-K8473-00	HANDRAIL ASSEMBLY (LH)	1				
5	J0B-K8474-00	HANDRAIL ASSEMBLY (RH)	1				
6	J0B-K8432-00	BRACKET, SEAT SUPPORT 2	1				
7	J0B-K8402-00	SEAT SUB ASSY, BACK	1				UR TAN
	J0B-K8402-10	SEAT SUB ASSY, BACK	1				UR BLACK
8	J0B-K8480-00	SEAT BOTTOM COMPLETE 1	1				UR TAN
	J0B-K8480-10	SEAT BOTTOM COMPLETE 1	1				UR BLACK
9	J0B-F47E2-00	HARDWARE KIT, TANDEM SEAT	1				
10	J0B-K8483-00	LABEL WARNING	1				
11	J0B-K8466-00	MAT, RUBBER	1				
12	J0B-F1696-00	LABEL, CAUTION	1				

NUMERICAL INDEX

PART NO.	REF. NO.	PART NO.	REF. NO.	PART NO.	REF. NO.	PART NO.	REF. NO.	PART NO.	REF. NO.	PART NO.	REF. NO.
401-22128-01	3 - 16	J0C-F3390-00	3 - 19	JW1-F467K-00	4 - 23	JW8-F7322-00	6 - 16	J0C-H1801-00	16 - 10	J0C-H3348-00	16 - 7
2NL-23448-00	3 - 9	J0B-F3392-00	20 - 19	J0B-F4681-00	20 - 3	J0C-F7411-01	2 - 5	J0C-H181K-00	16 - 18	JR1-H3383-02	18 - 24
2NL-23517-00	3 - 11	JW1-F3394-00	18 - 27		20 - 10	J0G-F7416-00	6 - 9	J0C-H181L-00	16 - 13	JN6-H3386-01	18 - 25
2HR-23526-00	3 - 3	JW1-F3400-00	4 - 10	J0B-F47E2-00	23 - 9	JW8-F7426-01	6 - 18	J0C-H1828-00	16 - 17	JW2-H351B-01	18 - 46
JW8-23841-01	4 - 27	J0B-F3418-00	20 - 11	JW1-F5100-01	9 - 1	JW8-F7434-00	6 - 39	JH7-H1829-00	16 - 28	JW9-H5885-00	6 - 52
J38-27204-00	7 - 15	J0B-F3432-00	20 - 28	JW8-F5103-00	3 - 21	JW8-F7435-00	6 - 56	J0C-H182A-00	16 - 6	JU2-H6171-20	18 - 11
J38-27205-00	7 - 4	J0B-F3447-00	12 - 2	JW8-F5118-00	8 - 38	JW8-F7438-00	6 - 38		16 - 23	JW9-H6172-00	18 - 12
J55-27260-00	7 - 9		12 - 5	JN6-F5118-01	3 - 29	J0H-F7445-10	6 - 33	J0C-H182G-00	16 - 11	JW9-H6181-00	18 - 26
J55-27270-00	7 - 20		12 - 13	JW8-F5415-00	6 - 26	J0G-F7814-00	6 - 23	J0C-H1835-00	16 - 22	JW2-H6510-30	17 - 1
J10-27282-00	7 - 6	5UG-F3489-00	4 - 20	J0B-F5522-00	20 - 14	JW8-F7814-21	6 - 3	J0C-H183J-00	16 - 16	JW2-H6527-00	18 - 31
	7 - 17	JU0-F3511-20	3 - 4	JW9-F5666-00	6 - 13	J0G-F7825-00	6 - 28	J0C-H1840-00	16 - 9	JU2-H7196-20	18 - 13
JF7-82817-22	18 - 28	JW1-F3512-00	3 - 5	J0G-F5671-00	6 - 4	J0H-F7850-20	6 - 1	J0C-H1843-00	16 - 12	JW2-H7209-20	19 - 2
JW9-85371-00	18 - 22	JU0-F3521-20	3 - 12	JW9-F5673-00	6 - 45	J0H-F7853-10	6 - 35	J0C-H1850-00	16 - 2	JW2-H7209-A0	19 - 5
J0B-F125J-00	2 - 19	5UG-F3527-00	4 - 21	JW8-F5681-10	5 - 5	J0G-F7854-00	6 - 5	J0C-H1856-00	16 - 14	JU2-HA2F0-00	18 - 37
1NS-F1338-00	18 - 39	J0B-F3570-10	3 - 1	JN6-F5685-01	5 - 6	J0C-H1857-01	6 - 36	J0C-H185A-00	16 - 24	J0B-K7115-00	4 - 37
JW1-F1549-01	22 - 9	J0G-F3811-00	4 - 1	JW9-F5827-00	6 - 53	J0H-F7872-00	6 - 37	J0C-H185B-00	16 - 15	J0B-K7145-20	21 - 16
	22 - 15	JW1-F3812-00	4 - 13	JW9-F5827-10	6 - 53	J0G-F815H-10	6 - 42	J0C-H1872-00	16 - 21	J0B-K7146-20	21 - 17
J0B-F1696-00	23 - 12	J0B-F381J-A0	20 - 6	J0G-F5922-00	6 - 43	JW8-F8323-00	6 - 25	J0C-H1890-01	16 - 1	J0B-K7147-20	21 - 23
J0B-F1738-00	2 - 6	JW1-F3822-01	4 - 29	JW8-F6314-00	6 - 22	JW8-F8331-00	6 - 47	JW9-H1892-00	18 - 2	J0B-K7148-20	21 - 24
	12 - 9	JU0-F3828-10	4 - 4	JW9-F632G-00	6 - 54	JW8-F8363-00	6 - 8	JW9-H1950-20	18 - 19	J0B-K7155-20	21 - 15
	12 - 14	1P0-F3833-00	4 - 26	JW9-F6351-10	5 - 1	JW8-G2535-00	8 - 34	JU2-H1962-00	19 - 3	J0G-K7155-C0	21 - 13
	15 - 5	JW1-F3837-00	4 - 22	JW8-F639N-00	6 - 10	JW8-G2536-00	8 - 35	JU2-H1962-20	19 - 3	J0G-K7156-C0	21 - 14
	15 - 7	J0A-F3838-00	4 - 6	JW8-F7118-00	6 - 41	JW8-G2541-00	8 - 39	JW2-H2107-51	19 - 1	J0B-K7173-21	21 - 10
JW1-F1738-00	2 - 8	J0B-F383A-00	20 - 22	JW8-F7119-00	6 - 29	JW8-G2756-00	8 - 36	JW2-H2107-A1	19 - 4	J0B-K7200-01	21 - 1
	2 - 11	J0B-F3841-A0	20 - 24	JW8-F7121-00	6 - 14	JH7-G3396-01	8 - 9	JW9-H210G-00	18 - 34	J0B-K7200-11	21 - 1
J0B-F178D-A0	20 - 5	5UG-F3844-00	4 - 19	J0G-F7200-02	6 - 2	JW8-G4178-00	8 - 32	J0C-H2113-00	16 - 19	J0B-K7200-24	21 - 9
J0C-F2110-00	1 - 1	J0B-F3849-A0	20 - 17	JW8-F7213-20	6 - 34	JW8-G5244-00	8 - 33	JW9-H2115-20	18 - 5	J0B-K7200-34	21 - 9
JN6-F2123-20	1 - 2	JU0-F3857-20	4 - 3	JW8-F7217-00	6 - 32	JW8-G5378-00	8 - 22	JW9-H2127-00	18 - 6	J0B-K7217-00	21 - 5
JN6-F2124-10	1 - 6		4 - 5	J0G-F7218-00	6 - 11	JW9-G6136-00	8 - 8	JW9-H2136-00	18 - 1		21 - 21
J0B-F2127-00	2 - 14	JW1-F3866-00	4 - 24	JW9-F7221-00	6 - 15	J0C-G6300-01	7 - 1	JW9-H2149-00	18 - 7	J0B-K7218-00	21 - 7
J0B-F2141-00	20 - 8	JW1-F387A-00	4 - 11	J0B-F7224-00	20 - 7		8 - 1	J0C-H2151-00	18 - 16		21 - 22
JW1-F217G-10	1 - 10	JW1-F387E-00	4 - 14	JW9-F7228-00	6 - 24	JW9-G6312-00	8 - 19	JR1-H2151-00	18 - 17	J0B-K7237-00	21 - 2
JW9-F2198-10	2 - 10	5UG-F387F-00	4 - 17	J0B-F722B-A3	20 - 1	JW9-G631A-00	8 - 18	J0E-H2151-10	18 - 18		21 - 11
J0C-F2210-00	1 - 14	5UG-F387G-00	4 - 15	JW9-F7231-10	6 - 19	JW9-G6321-00	8 - 3	JU2-H218E-01	16 - 29	J0B-K7238-00	21 - 3
JW9-F2417-00	2 - 9	5UG-F387J-00	4 - 18	JW9-F7232-00	6 - 20	JW9-G6350-00	8 - 11	J0B-H2370-00	11 - 14	J0B-K7240-01	21 - 4
J0A-F2501-10	2 - 1	5UG-F387K-00	4 - 16	JW9-F7245-10	6 - 30	JW9-G6410-00	8 - 15	JW1-H2510-00	18 - 41	J0B-K7240-20	21 - 19
JW9-F252M-00	2 - 4	J0B-F3880-A0	20 - 21	JW9-F7246-20	6 - 46	JW9-G6421-00	8 - 13	JU2-H2510-20	18 - 45	J0B-K7247-00	21 - 26
JW9-F2535-00	2 - 7	JW1-F389A-00	4 - 25	JW9-F7263-00	6 - 49	JN3-G6432-00	8 - 20	JU2-H2511-00	18 - 43	J0B-K7248-00	21 - 6
J0B-F255G-00	2 - 2	J0B-F389G-00	20 - 16	JW8-F7280-10	7 - 13	JR1-G6511-00	8 - 25	JU2-H2521-20	18 - 9		21 - 20
J0B-F258E-10	2 - 12	J0B-F389J-A0	20 - 2	JW8-F7281-00	7 - 5	JR1-G6512-00	8 - 26	JU2-H2531-20	18 - 10	J0B-K7257-20	21 - 12
J0B-F2873-01	12 - 15	J0B-F389K-A1	20 - 15		7 - 16	JW8-G6514-00	8 - 31	JU6-H2569-00	18 - 44	JW7-K7329-00	12 - 8
J0B-F2874-01	12 - 16	JW1-F414G-10	22 - 1	JW8-F7286-00	7 - 10	JW8-G6521-00	8 - 37	5UG-H2579-00	18 - 42	J0B-K7363-00	4 - 36
JW7-F312H-00	5 - 4	J0B-F4161-00	11 - 2		7 - 21	JW1-H1128-00	18 - 47	J0C-H2590-21	18 - 15	J0B-K7387-00	4 - 34
J0G-F3145-00	6 - 57	J0B-F417A-00	22 - 17	JW8-F7290-10	7 - 2	J0C-H1160-00	16 - 3	J0C-H2590-31	18 - 15	JW1-K7387-00	22 - 11
J0B-F3147-20	21 - 25	JW8-F41B8-00	6 - 51	J0G-F7313-00	6 - 12	J0C-H1617-00	16 - 8	JW2-H2727-00	17 - 2	J0B-K7389-00	14 - 5
JW1-F3183-00	4 - 12	JW8-F4486-00	6 - 44	JW8-F7316-01	6 - 31	J0C-H1670-00	16 - 20	J0C-H272L-00	16 - 4	J0B-K7510-01	10 - 1
JW8-F3183-00	6 - 17		6 - 48	JW8-F7317-00	6 - 40	JW9-H1674-00	15 - 1	J0C-H272N-00	16 - 5	J0B-K7529-20	21 - 18
J0C-F3350-00	3 - 14	JW9-F4648-20	6 - 50	JW8-F7318-00	6 - 21		17 - 3	JU2-H2917-00	18 - 8	J0B-K7540-00	10 - 7



NUMERICAL INDEX

PART NO.	REF. NO.	PART NO.	REF. NO.	PART NO.	REF. NO.	PART NO.	REF. NO.	PART NO.	REF. NO.	PART NO.	REF. NO.
JU0-K7573-00	11 - 3	J0B-K8164-00	10 - 2	J0B-K838A-20	21 - 27	90119-10044	1 - 5	90387-12016	3 - 15	95602-10200	20 - 25
J0C-K7741-00	11 - 10	J1B-K816M-00	2 - 15	JU0-K8398-00	22 - 10	90159-06845	14 - 13	90387-241M7	3 - 25	95602-12200	20 - 13
J0B-K7761-A0	20 - 31	J0B-K817H-00	12 - 20		22 - 16	90170-08841	8 - 24	90461-14108	18 - 35		20 - 20
J0B-K7762-10	4 - 38	J0B-K817H-10	12 - 20	J0A-K8401-10	15 - 3	90170-10840	8 - 17	90464-14134	18 - 40	95602-14100	3 - 28
J0B-K7762-20	4 - 38	J0B-K817J-00	12 - 21	J0B-K8402-00	23 - 7	90176-06008	14 - 6	90464-20005	18 - 32	95607-06200	6 - 6
J0B-K7768-30	11 - 8	J0B-K817J-10	12 - 21	J0B-K8402-10	23 - 7	90179-05807	18 - 20	90464-25826	18 - 14	95802-10035	20 - 9
J0B-K7768-40	11 - 8	J0B-K818A-00	13 - 2	JW1-K8402-10	15 - 10	90179-08822	5 - 7	90464-40825	18 - 30	95802-10050	20 - 4
J0B-K7768-50	11 - 8	J0B-K818B-00	13 - 5	J0B-K8423-00	14 - 1	90179-08824	18 - 21	90464-48800	18 - 38	95812-06025	20 - 32
J0B-K7768-60	11 - 8	J0B-K8191-00	13 - 8	J0B-K8426-01	15 - 8	90179-12262	9 - 2	90464-76800	2 - 20	95812-08016	10 - 3
J0B-K8111-00	12 - 1	J0B-K8192-00	13 - 10	JW1-K8427-00	15 - 2	90179-13800	1 - 4	90468-20196	5 - 3	95812-08020	4 - 2
J0B-K8111-10	12 - 1	J0B-K819H-00	12 - 7	J0B-K8432-00	23 - 6	90183-05008	11 - 13	90506-14001	7 - 8		6 - 58
J0B-K8111-30	12 - 1	JW1-K8214-00	22 - 13	J0B-K8460-00	23 - 2	90185-06836	14 - 11		7 - 19	95812-08040	2 - 3
J0B-K8111-50	12 - 1	J0B-K821A-00	2 - 18	J0B-K8466-00	23 - 11	90185-12008	4 - 7	90506-20281	7 - 7	95812-08050	10 - 4
J0B-K8111-60	12 - 1	J0B-K8233-00	11 - 15	J0B-K8473-00	23 - 4	90185-12810	3 - 18		7 - 18	95812-10055	1 - 15
J0B-K8111-A0	12 - 1	J0B-K8237-02	12 - 12	J0B-K8474-00	23 - 5	90185-12811	1 - 8	91402-25020	20 - 26	95812-12065	1 - 7
J0B-K8111-B0	12 - 1	J0B-K8243-00	11 - 18	J0B-K8477-00	23 - 3		4 - 9	91490-25015	5 - 12	95812-12080	3 - 17
J0B-K8111-R0	12 - 1	J0B-K8244-00	11 - 20	J0B-K8480-00	23 - 8	90201-04810	4 - 35	91490-30030	8 - 27	95822-06012	10 - 6
J0B-K8111-S0	12 - 1	J0B-K8271-01	13 - 1	J0B-K8480-10	23 - 8	90201-05824	6 - 55	91702-08018	5 - 11	95822-06016	17 - 4
J0B-K8112-00	12 - 4	J0B-K8273-10	11 - 17	J0B-K8483-00	23 - 10	90201-06102	20 - 33	91702-10026	5 - 2	97012-06020	6 - 7
J0B-K8112-10	12 - 4	J0C-K827A-00	12 - 17	J0B-K84A0-00	22 - 2	90201-068E2	16 - 27	92017-06040	14 - 4	97012-08030	4 - 30
J0B-K8112-30	12 - 4	J0B-K8282-00	11 - 9	J0B-K84A0-10	22 - 2	90201-08310	18 - 3	92902-08600	4 - 31	97012-10020	1 - 11
J0B-K8112-50	12 - 4	JW9-K8297-01	12 - 19	J0B-K84A2-00	22 - 3	90201-121H8	7 - 12	92902-10100	1 - 12	9708R-06020	14 - 10
J0B-K8112-60	12 - 4	JW9-K8297-11	12 - 19	JN9-WV2536-11	7 - 3		7 - 23	92902-10600	1 - 13	97602-05225	18 - 29
J0B-K8112-A0	12 - 4	J0C-K8298-00	12 - 18		7 - 14	90201-121H9	7 - 11	92902-12200	4 - 8	99001-09600	5 - 10
J0B-K8112-B0	12 - 4	J0C-K8298-10	12 - 18	90101-069U0	16 - 25		7 - 22	9299R-06200	14 - 14		
J0B-K8112-R0	12 - 4	J0B-K8312-00	22 - 4	90101-08855	8 - 23	90201-128S4	1 - 9	93101-24822	8 - 28		
J0B-K8112-S0	12 - 4	JW1-K8313-01	22 - 6	90101-08856	8 - 21		20 - 12	93102-30083	3 - 26		
J0B-K8114-01	11 - 6	JW1-K8314-10	22 - 12	90101-10854	8 - 16	90201-208S8	20 - 18	93210-148B9	8 - 12		
J0C-K8114-01	11 - 6	JW1-K8314-21	22 - 12	90105-06831	2 - 16	90208-14801	3 - 27	93210-478B8	8 - 5		
J0B-K8115-00	11 - 1	J0B-K832F-00	11 - 22		11 - 4	90215-06811	16 - 26	93306-00440	8 - 30		
J0B-K8115-10	11 - 1	J1B-K832F-00	11 - 22		18 - 23	90249-14129	5 - 9	93306-005Y1	8 - 6		
J0B-K8115-30	11 - 1	J0B-K832G-00	11 - 23	90105-08867	2 - 13	90269-06804	11 - 5	93306-005Y3	3 - 24		
J0B-K8115-50	11 - 1	J1B-K832G-00	11 - 23		18 - 36		13 - 4	93306-007Y0	8 - 14		
J0B-K8115-60	11 - 1	JW1-K8340-00	14 - 3	90105-088A9	20 - 27		13 - 7	93306-203X1	8 - 7		
J0B-K8115-A0	11 - 1	JW1-K834G-00	14 - 9	90105-088B6	2 - 17		13 - 9	93306-204X0	3 - 23		
J0B-K8115-B0	11 - 1	JN6-K8355-20	14 - 8	90105-10219	3 - 8		13 - 11	93306-303Y6	8 - 10		
J0B-K8115-R0	11 - 1	JF2-K8356-00	14 - 7	90105-10267	3 - 13	90269-07805	11 - 19	93420-44805	8 - 29		
J0B-K8115-S0	11 - 1	J0B-K8357-00	4 - 32		3 - 20		11 - 21	93420-50804	8 - 4		
JW9-K811K-00	18 - 4	J0B-K8358-00	4 - 33	90105-10373	3 - 6		12 - 3	95302-08700	10 - 5		
J0C-K8141-00	12 - 10	J0B-K835E-00	11 - 11	90105-10840	8 - 2		12 - 6	95302-10600	20 - 23		
J0C-K8141-10	12 - 10	J0B-K8361-00	15 - 4	90105-10847	4 - 28		12 - 11	95307-08700	5 - 8		
J0C-K8141-30	12 - 10	J0B-K8362-00	15 - 6	90105-13800	1 - 3	90269-08001	11 - 7	95602-06200	17 - 5		
J0C-K8141-50	12 - 10	JN6-K8380-00	14 - 12	90109-08178	14 - 2	90269-09003	11 - 16		20 - 34		
J0C-K8141-60	12 - 10	J0B-K8388-00	22 - 7		23 - 1		13 - 3	95602-08100	20 - 30		
J0C-K8141-A0	12 - 10	JU0-K8388-00	22 - 8	90110-06125	15 - 9		13 - 6	95602-08200	20 - 29		
J0C-K8141-B0	12 - 10		22 - 14	90111-05805	11 - 12	90381-17800	3 - 10	95602-10200	1 - 16		
J0C-K8141-R0	12 - 10	JW1-K8388-00	22 - 5	90114-12806	3 - 22	90381-18801	3 - 2		3 - 7		
J0C-K8141-S0	12 - 10	J0B-K838A-20	21 - 8	90119-06808	15 - 11	90386-12800	6 - 27		10 - 8		