



PARTS CATALOGUE

G22-AX (JU02) U.S.A., CANADA, OTHERS



2010-05-17

1DJU0-100E1

(2DJU0-100E1)

NEWS No.	DATE	COMMENT
PE0-GC-050003	Oct.,12,2005	FIG.19: ACCELERATOR LIST CORRECTION
PE0-GC-100002	May,14,2010	COR: FIG.17 BRAKE2, FIG.18 BRAKE3 LIST&ILLUSTRATION CORRECTION

G22-AX
PARTS CATALOGUE
©2005 by Yamaha Motor Co., Ltd.
1st edition, February 2005
All rights reserved.
Any reprinting or unauthorized use
without the written permission of
Yamaha Motor Co., Ltd.
is expressly prohibited.
Printed in Japan.

A3

FOREWORD

This Parts Catalogue is related to the parts for the model(s) on the cover page. When you are ordering replacement parts, please refer to this Parts Catalogue and quote both part numbers and part names correctly.

1. Modifications or additions which have been made after the issue of the Parts Catalogue will be announced in the Parts News.

It is advisable that you make the necessary corrections to the Parts Catalogue according to the Parts News.

2. Abbreviations

The following abbreviations are used in this Parts Catalogue.

“UR” Use specified parts number.

“UN” Use as many as needed.

“AP” Alternate Parts

“LM” Locally Made (Parts need to be ordered locally)

“F#” Frame No. (Applicable machine No.)

“O/S” Over Size

3. The number of components for assembly

- Parts, which are to be supplied in an assembly, are listed with a dot (.) in front of the part name as shown below.
- The numeral appearing to the right of each component part indicates the quantity of parts for each assembly unit.

PART NO.	DESCRIPTION	Q'TY	REMARKS
2F5-83310-60	FRONT FLASHER LIGHT ASSY	2	
115-83311-60	.BULB (6V-18W)	1	

4. Applicable colours of graphics are represented in the “REMARKS” as shown below.

PART NO.	DESCRIPTION	Q'TY	REMARKS
2N4-24110-00-X5	FUEL TANK COMP.	2	MXR
3J1-24240-10	.GRAPHIC, FUEL TANK	1	FOR MXR

5. Note that the illustrations for reference in finding parts numbers are not to be used for assembling. When assembling, please use the applicable service manual.

6. The asterisk (*) before a reference number indicates modified items after the first edition.

FOREWORD

7. Applicable Serial No.

Engine Serial No.

Frame Serial No.

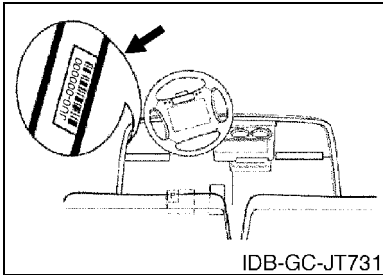
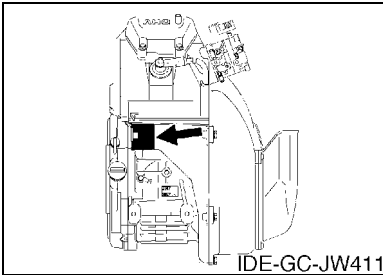

10. Applicable Starting Serial No.

Frame Serial No.

Serial No.	Name Of Q'ty Column	Model Code
JU0-*****	JU02	JU02

8. Applicable Colour Code (The (*) mark shows Model colour.)

Abbreviation	Colour Name	Colour Code
DPBMP(*)	DARK PURPLISH BLUE METALLIC P	0927
DPBMT(*)	DEEP PURPLISH BLUE METALLIC T	0978
DRMG(*)	DARK RED METALLIC G	0811
HTR(*)	HEAT RED	00EY
VDGS1(*)	VERY DARK GREEN SOLID 1	0614
VPYS2(*)	VERY PALE YELLOW SOLID 2	0500

9. Quantity Column Information

Column No.	Name Of Q'ty Column	Destination
1	JU02	U.S.A.,CANADA,OTHERS

CONTENTS

ENGINE

ENGINE ASSEMBLY	B2
CYLINDER HEAD	B3
CRANKSHAFT & PISTON	B4
CAMSHAFT & VALVE	B5
AIR SHROUD & FAN	B6
INTAKE	B7
CARBURETOR	B8
EXHAUST	B9
CRANKCASE	B10

BODY

ENGINE BRACKET	B11
REAR ARM & SUSPENSION	B12
FRAME	B13
FRONT SUSPENSION & WHEEL	B14
STEERING	C2
FUEL TANK	C4
BRAKE	C5
BRAKE 2	C7
BRAKE 3	C8
ACCELERATOR	C9
GOVERNOR	C10

DRIVE

PRIMARY SHEAVE	C11
SECONDARY SHEAVE	C12
TRANSMISSION 1	C13
REAR AXLE MOUNT & WHEEL	D2
SHIFTER & CABLES	D3
BUMPER	D4
BODY	D5
BODY 2	D7
BODY FITTING	D9
CARRIER	D10
SEAT	D11

ELECTRICAL

STARTING MOTOR	D13
ELECTRICAL 1	D15
ELECTRICAL 2	E2
ALTERNATE FOR WINDSHIELD	E4

ALTERNATE FOR SUN ROOF	E5
ALTERNATE FOR LIGHT KIT	E6

INDEX

NUMERICAL INDEX	M1
-----------------------	----

FIG. 1 ENGINE ASSEMBLY

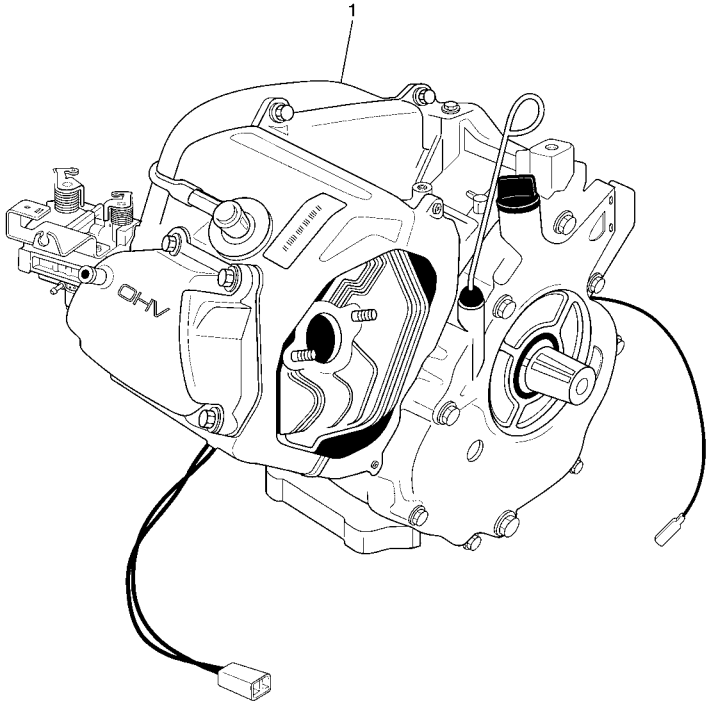

REF. NO.	PART NO.	DESCRIPTION	JU02				REMARKS
1	JR6-19001-00	ENGINE ASSEMBLY	1				



 JW41110-C010

FIG. 2 CYLINDER HEAD

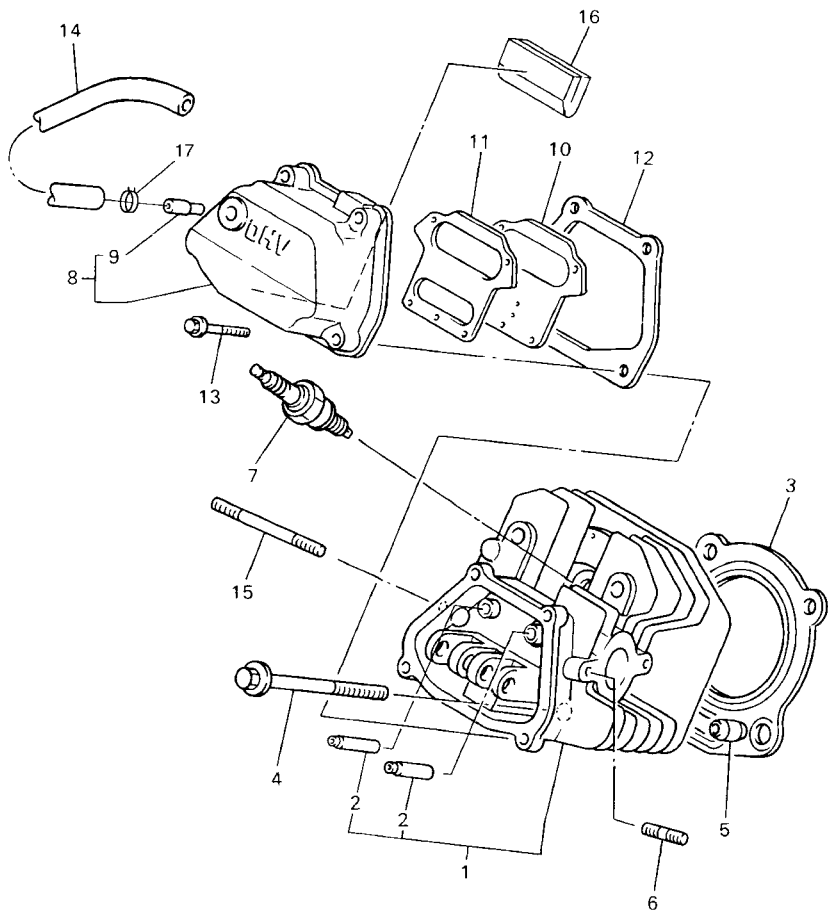
REF. NO.	PART NO.	DESCRIPTION	JU02				REMARKS
1	JT0-11111-00	HEAD, CYLINDER 1	1				
2	JN6-11133-10	.GUIDE, VALVE 1	2				
3	JT0-11181-00	GASKET, CYLINDER HEAD 1	1				
4	95817-10070	BOLT, FLANGE	4				
5	99530-14016	PIN, DOWEL	2				
6	95627-08618	BOLT, STUD	2				
7	94702-00348	PLUG, SPARK (NGK-BPR2ES)	1				STD
	94702-00343	PLUG, SPARK (NGK BP4ES)	1				AP
8	JN6-11191-01	COVER, CYLINDER HEAD 1	1				
9	JN6-11116-00	.JOINT, BREATHER	1				
10	JN6-11168-00	COVER, BREATHER	1				
11	JN6-11169-00	GASKET, BREATHER COVER	1				
12	JN6-11193-00	GASKET, HEAD COVER 1	1				
13	95827-06030	BOLT, FLANGE	4				
14	JN6-E1166-00	PIPE, BREATHER 1	1				
15	95607-08710	BOLT, STUD	2				
16	JR7-11163-00	ELEMENT	1				
17	90467-13847	CLIP	2				

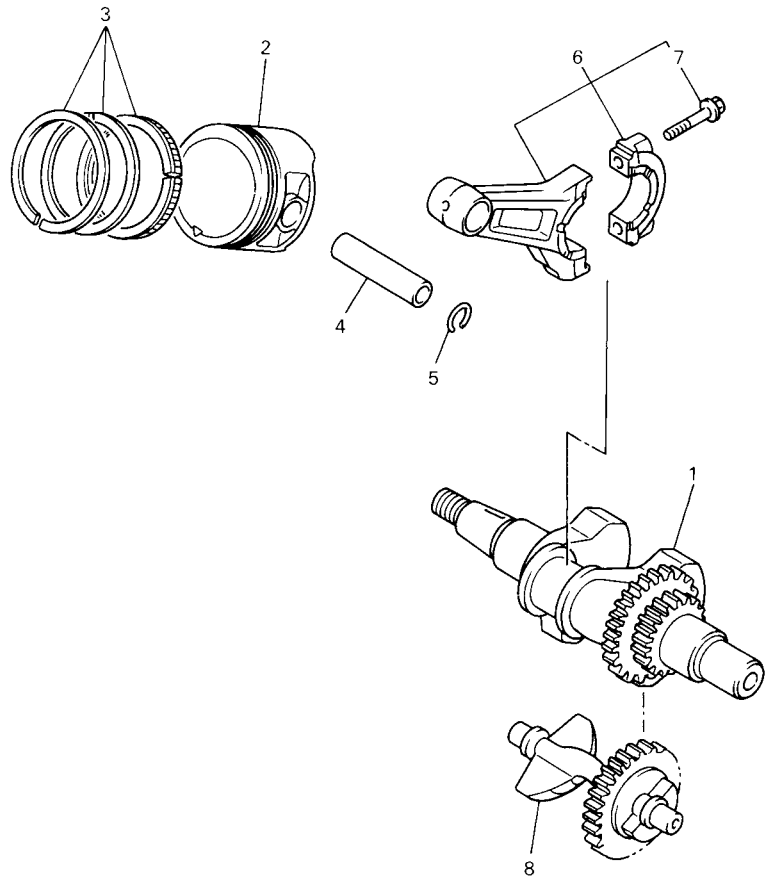

JT01010-0011





JN7010-6020

FIG. 3 CRANKSHAFT & PISTON

REF. NO.	PART NO.	DESCRIPTION	JU02				REMARKS
1	JN6-11400-00	CRANKSHAFT ASSY	1				
2	JR7-11631-00-A0	PISTON (STD)	1				
	JR7-11635-00	PISTON (0.25MM O/S)	1				AP
	JR7-11636-00	PISTON (0.50MM O/S)	1				AP
3	JR7-11610-00	PISTON RING SET (STD)	1				
	JR7-11610-10	PISTON RING SET (0.25MM O/S)	1				AP
	JR7-11610-20	PISTON RING SET (0.50MM O/S)	1				AP
4	583-11633-00	PIN, PISTON	1				
5	93450-21053	CIRCLIP	2				
6	JN6-11650-00	CONNECTING ROD ASSY	1				
7	JN6-11654-00	BOLT, CONNECTING ROD	2				
8	JN6-11454-00	WEIGHT 1	1				

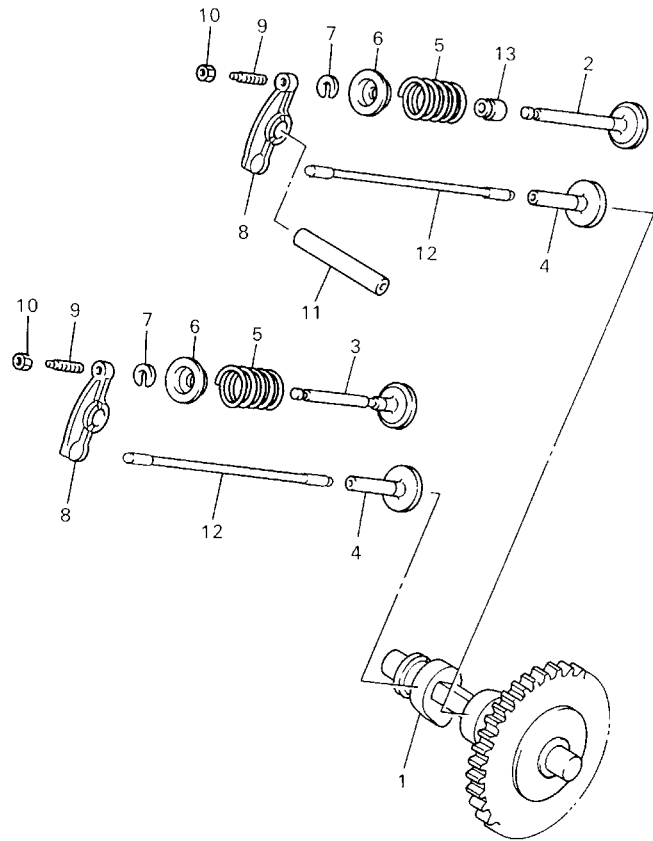
FIG. 4 CAMSHAFT & VALVE



REF. NO.	PART NO.	DESCRIPTION	JU02				REMARKS
1	JR7-12170-00	CAMSHAFT ASSY 1	1				
2	JN6-12111-01	VALVE, INTAKE	1				
3	7RH-12121-00	VALVE, EXHAUST	1				
4	JN6-12153-00	LIFTER, VALVE	2				
5	90501-264A9	SPRING, COMPRESSION	2				
6	J38-12117-01	RETAINER, VALVE SPRING	2				
7	J38-12118-00	COTTER, VALVE	2				
8	JN6-12151-00	ARM, VALVE ROCKER	2				
9	22F-12159-00	SCREW, VALVE ADJUSTING	2				
10	90170-05302	NUT	2				
11	J38-12156-00	SHAFT, ROCKER 2	1				
12	JR7-12154-01	ROD, VALVE PUSH	2				
13	4G0-12119-00	SEAL, VALVE STEM	1				

FWD
JT01010-0030

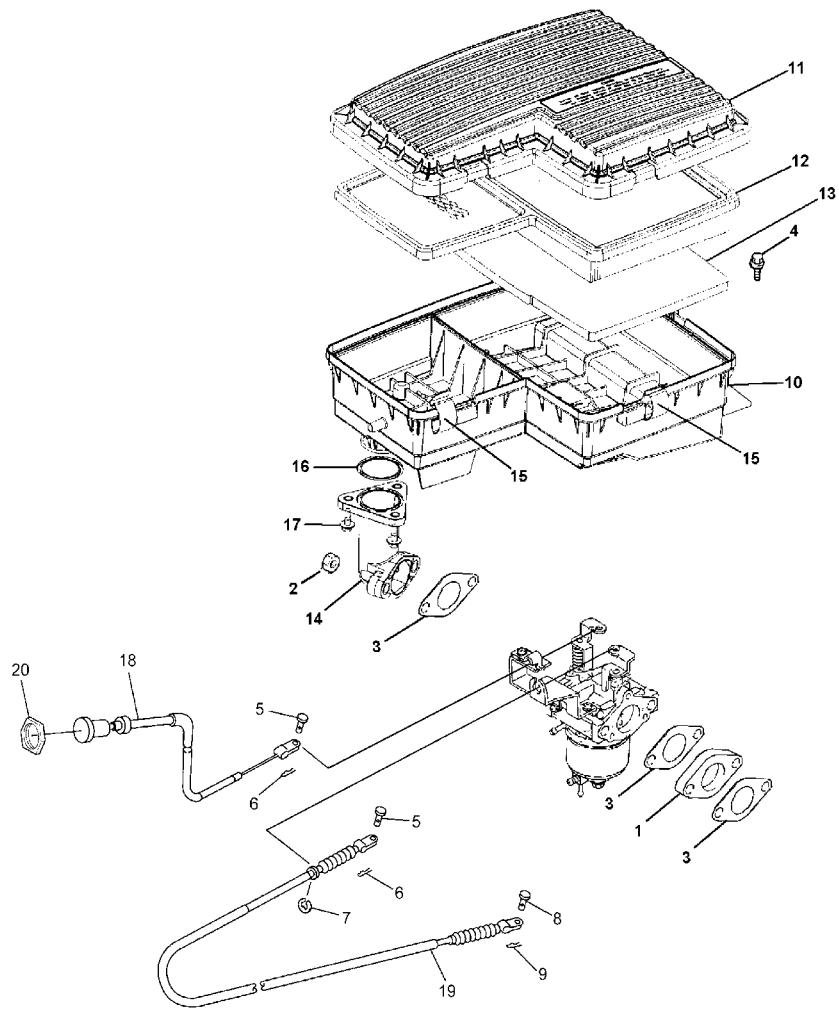

JU0100-5050

FIG. 6 INTAKE

REF. NO.	PART NO.	DESCRIPTION	JU02				REMARKS
1	JN6-13595-00	JOINT	1				
2	95707-08500	NUT, FLANGE	2				
3	JN6-13567-00	GASKET	3				
4	90119-06838	BOLT, WITH WASHER	2				
5	91701-05010	PIN, CLEVIS	2				
6	90468-10049	CLIP	2				
7	99001-07600	CIRCLIP	1				
8	91701-05010	PIN, CLEVIS	1				
9	90468-10049	CLIP	1				
10	JU0-E4411-00	CASE, AIR CLEANER 1	1				
11	JU0-E4412-00	CAP, CLEANER CASE 1	1				
12	JU0-E4450-00	ELEMENT ASSY, AIR CLEANER	1				
13	JU0-E445E-00	FILTER 1	1				
14	JU0-E3586-00	JOINT, CARBURETOR 1	1				
15	5UH-E4424-00	CLIP, CAP FITTING	5				
16	93210-398D6	O-RING	1				
17	90105-06862	BOLT, FLANGE	3				
18	JN6-F6331-11	CABLE, STARTER 1	1				
19	JN6-F6312-01	CABLE, THROTTLE 2	1				
20	JN6-F6333-10	NUT	1				

FIG. 7 CARBURETOR

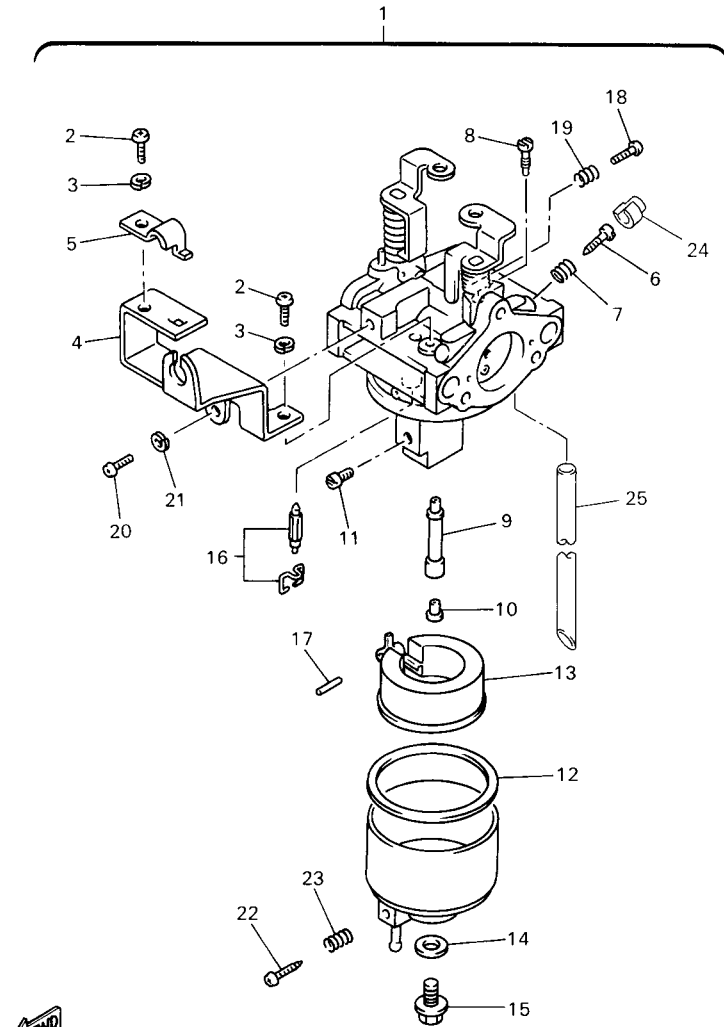

JR61100-1060

REF. NO.	PART NO.	DESCRIPTION	JU02				REMARKS
1	JR6-14101-00	CARBURETOR ASSY 1	1				
2	98507-05008	.SCREW, PAN HEAD	2				
3	92990-05100	.WASHER, SPRING	2				
4	JN6-14291-00	.BRACKET 1	1				
5	J10-14227-00	.PLATE	1				
6	7NJ-14211-00	.SCREW, PILOT ADJUSTING	1				
7	73A-14212-10	.SPRING	1				
8	732-14142-65-A0	.JET, PILOT (# 65)	1				
9	JN6-1495H-3B	.NOZZLE, MAIN	1				
10	73A-1414G-00	.PIPE, MAIN BREED	1				
11	3G2-1423A-68-A0	.JET, MAIN (# 87.5)	1				STD
	3G2-1423A-67	.JET, MAIN (# 82.5)	1				AP
	3G2-1423E-33-A0	.JET, MAIN (#83.8)	1				AP
12	796-14184-00	.GASKET, FLOAT CHAMBER	1				
13	JN6-14185-00	.FLOAT	1				
14	127-14198-00	.GASKET	1				
15	7R1-14162-00	.BOLT, HOLDING	1				
16	JN5-14150-00	.NEEDLE ASSY (WITH CLIP)	1				
17	22F-14186-00	.PIN, FLOAT	1				
18	1WG-14922-00	.SCREW, THROTTLE	1				
19	73A-14212-10	.SPRING	1				
20	98507-04010	.SCREW, PAN HEAD	1				
21	92902-04100	.WASHER, SPRING	1				
22	7E1-14191-00	.PLUG, DRAIN	1				
23	73A-14212-00	.SPRING	1				
24	7LV-14118-00	.CAP	1				
25	1KT-14197-01	.PIPE	1				

FIG. 8 EXHAUST

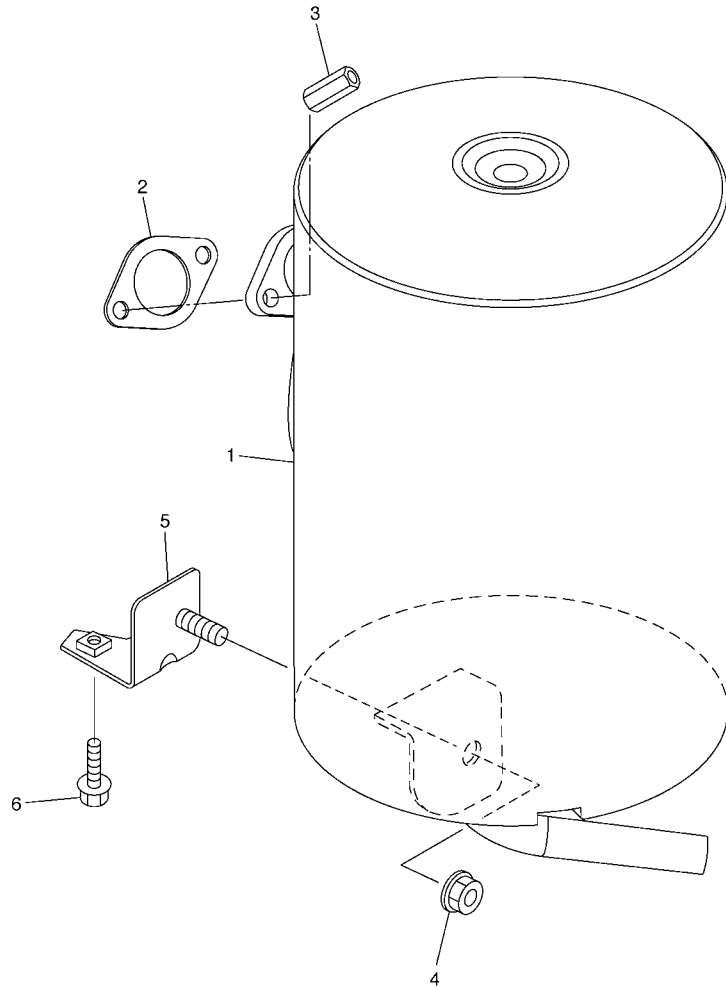

REF. NO.	PART NO.	DESCRIPTION	JU02				REMARKS
1	JU0-E4710-10	MUFFLER ASSY 1	1				
2	7KY-14613-01	GASKET, EXHAUST 1	1				
3	90179-08879	NUT	2				
4	90185-08841	NUT, SELF-LOCKING	1				
5	JU0-F1436-00	BRKT., MUFF. 2	1				
6	90119-08825	BOLT, WITH WASHER	1				

 JU02100-D080

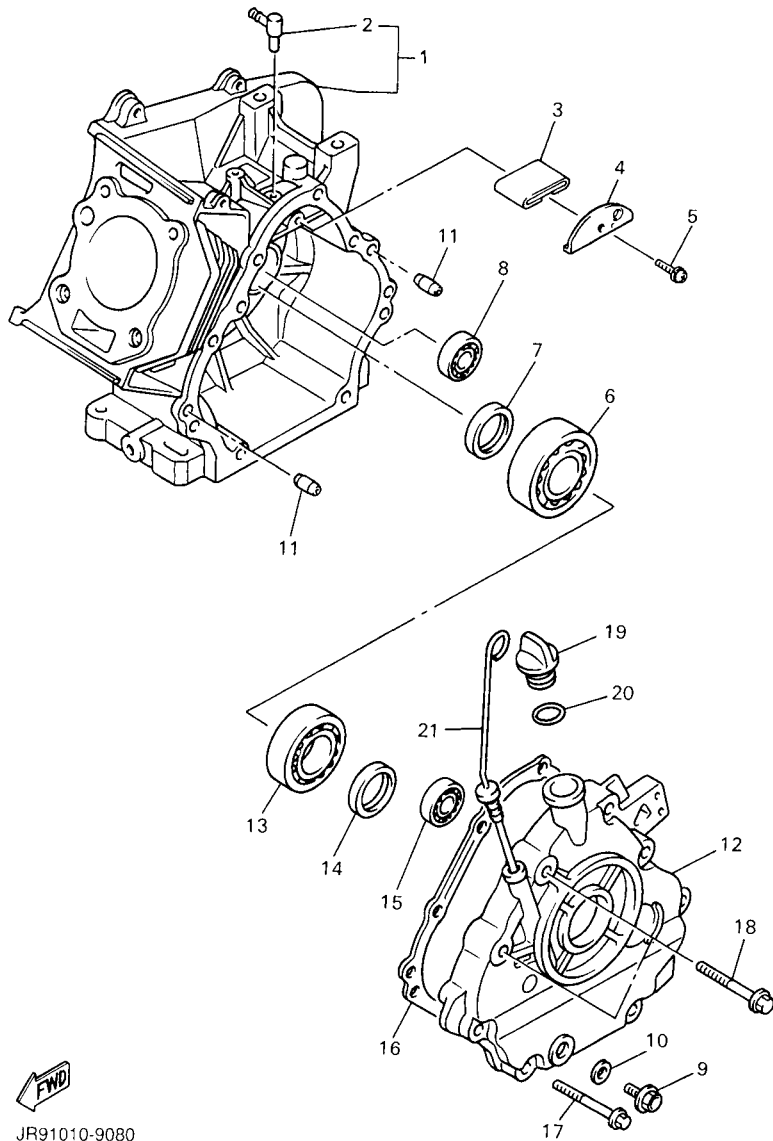

JR91010-9080

FIG. 9 CRANKCASE

REF. NO.	PART NO.	DESCRIPTION	JU02				REMARKS
1	JR7-15100-00	CRANKCASE ASSY	1				
2	JN6-15155-00	.NOZZLE 3	1				
3	JR7-15407-00	ELEMENT 1	1				
4	JR7-15123-00	PLATE, BUFFLE 1	1				
5	90159-06107	SCREW, WITH WASHER	1				
6	93306-30709	BEARING	1				
7	93102-35014	OIL SEAL	1				
8	93306-20201	BEARING	1				
9	90340-12097	PLUG, STRAIGHT SCREW	1				
10	812-11198-00	GASKET	1				
11	99530-08016	PIN, DOWEL	2				
12	JN6-15411-01	COVER, CRANKCASE 1	1				
13	93306-20714	BEARING	1				
14	93102-35014	OIL SEAL	1				
15	93306-20201	BEARING	1				
16	JN6-15451-02	GASKET, CRANKCASE COVER 1	1				
17	95817-08045	BOLT, FLANGE	6				
18	95817-10050	BOLT, FLANGE	2				
19	796-15363-01	PLUG, OIL	1				
20	93210-22344	O-RING	1				
21	J38-15361-00	GAUGE, LEVEL	1				

FIG. 10 ENGINE BRACKET

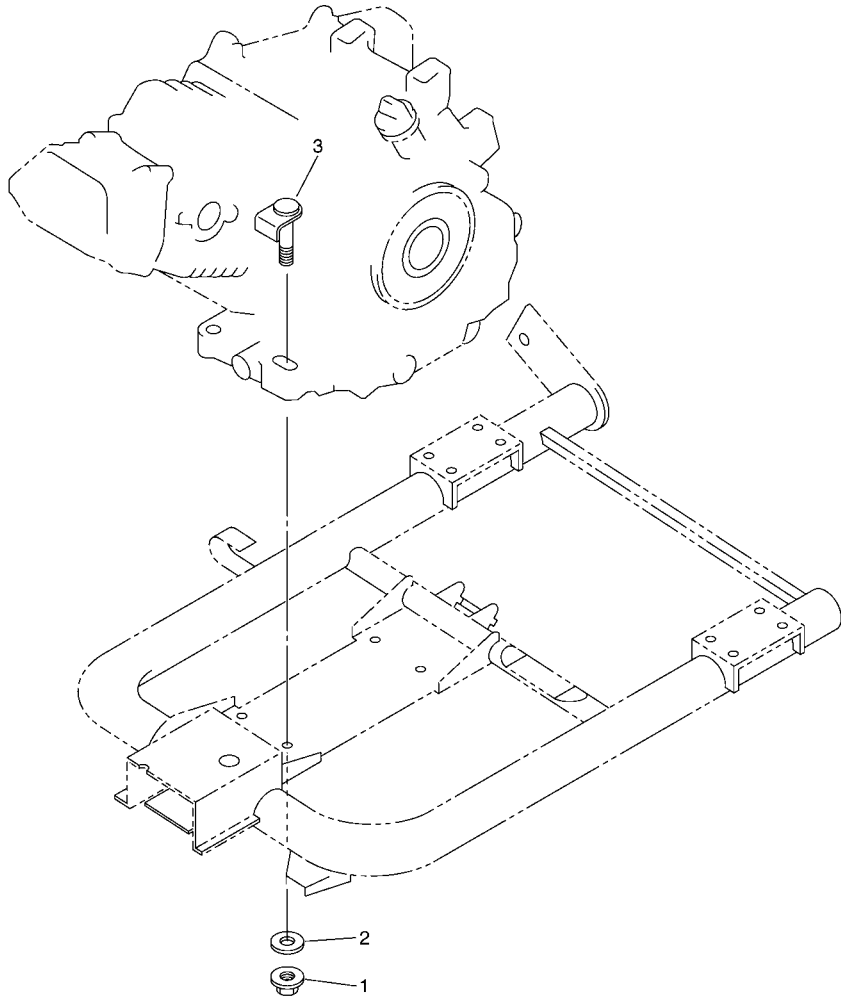

JU02100-D100

REF. NO.	PART NO.	DESCRIPTION	JU02				REMARKS
1	9560P-10200	NUT, FLANGE	4				
2	9290P-10200	WASHER	4				
3	JT0-21481-00	BOLT, ENGINE MOUNTING 1	4				

FIG. 11 REAR ARM & SUSPENSION

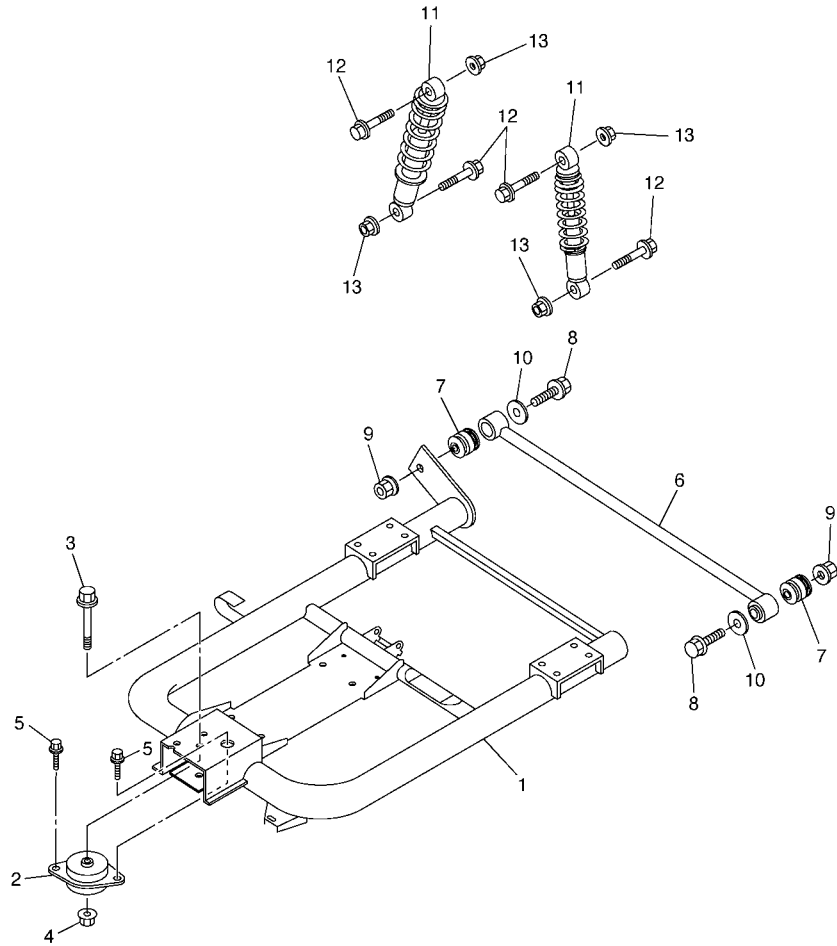

JU02100-D110

REF. NO.	PART NO.	DESCRIPTION	JU02				REMARKS
1	JU0-F2110-10	REAR ARM COMP.	1				
2	JN6-F2123-10	BUSH 1	1				
3	90105-13864	BOLT, FLANGE	1				
4	90179-13878	NUT	1				
5	9751P-10620	BOLT, WITH WASHER	2				
6	JN6-F217G-00	ROD, CONNECTING 2	1				
7	JN6-F2124-10	BUSH 2	2				
8	9581P-12065	BOLT, FLANGE	2				
9	9560P-12200	NUT, FLANGE	2				
10	90201-128S4	WASHER, PLATE	2				
11	JN4-F2210-00	SHOCK ABSORBER ASSY, REAR	2				
12	95807-10055	BOLT, FLANGE	4				
13	95607-10200	NUT, U FLANGE	4				

FIG. 12 FRAME

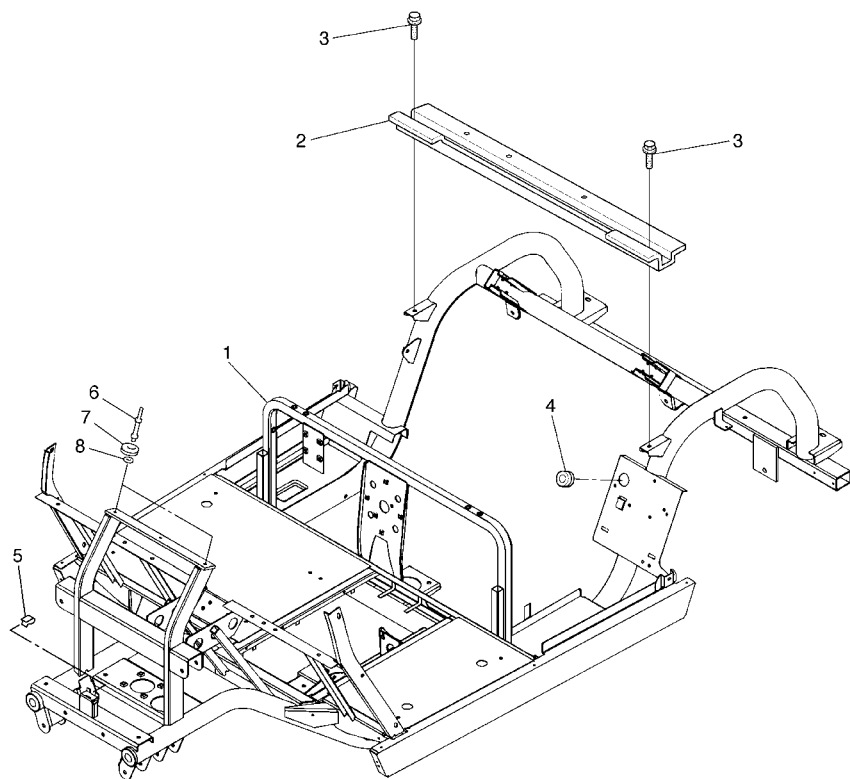

REF. NO.	PART NO.	DESCRIPTION	JU02				REMARKS
1	JU0-F2501-00	FRAME COMP.	1				
2	JU0-F254R-00	SUPPORT, BODY MOUNTING	1				
3	95807-08016	BOLT, FLANGE	2				
4	90480-25856	GROMMET	1				
5	JU0-F2567-00	SUPPORT 1	1				
6	JU0-K834A-00	REINF.,HOLDER	2				FOR SUN ROOF
7	JN3-K832F-00	GROMMET, ROOF SUPPORT 1	2				FOR SUN ROOF
8	90201-11800	WASHER, PLATE	2				FOR SUN ROOF



JU02100-D120

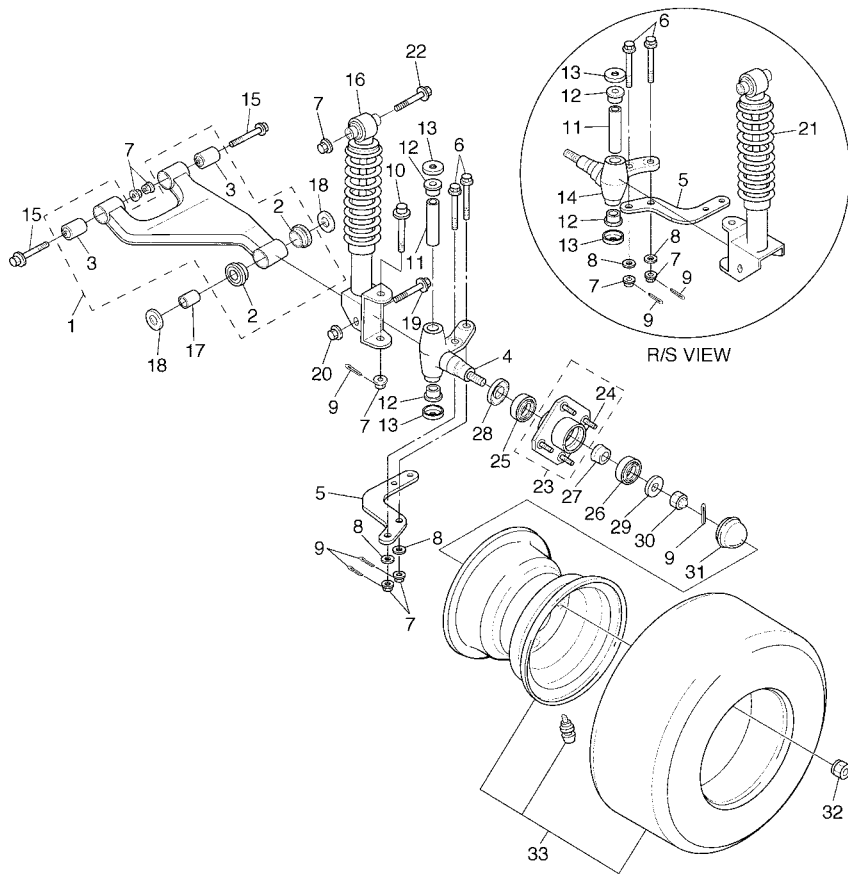

FIG. 13 FRONT SUSPENSION & WHEEL

REF. NO.	PART NO.	DESCRIPTION	JU02				REMARKS
1	JU0-F3570-20	FRONT LOWER ARM COMP.	2				
2	90381-18001	.BUSH, SOLID	2				
3	2HR-23526-00	.BUSH	2				
4	JU0-F3511-00	KNUCKLE, STEERING 1	1				
5	JU0-F3512-01	ARM, KNUCKLE 1	2				
6	90105-10728	BOLT, FLANGE	4				
7	95607-10200	NUT, U FLANGE	12				
8	90201-108P8	WASHER, PLATE	4				
9	91401-25020	PIN, COTTER	8				
10	90105-10064	BOLT, FLANGE	2				
11	2NL-23448-00	SPACER	2				
12	90381-17067	BUSH, SOLID	4				
13	2NL-23517-00	COVER, THRUST 1	4				
14	JU0-F3521-00	KNUCKLE, STEERING 2	1				
15	90105-10890	BOLT, FLANGE	4				
16	JU0-F3350-20	SHOCK ABSORBER ASSY	1				
17	90387-12016	COLLAR	2				
18	401-22128-01	COVER, THRUST 1	4				
19	95817-12080	BOLT, FLANGE	2				
20	9561P-12100	NUT	2				
21	JU0-F3390-20	SHOCK ABSORBER ASSY 2	1				
22	95807-10065	BOLT, FLANGE	2				
23	JG5-WF511-10	HUB, FRONT	2				
24	90114-12800	.BOLT, SERRATION	4				
25	93306-204X0	BEARING	2				
26	93306-005Y3	BEARING	2				
27	90387-241M7	COLLAR	2				



JT73010-C120

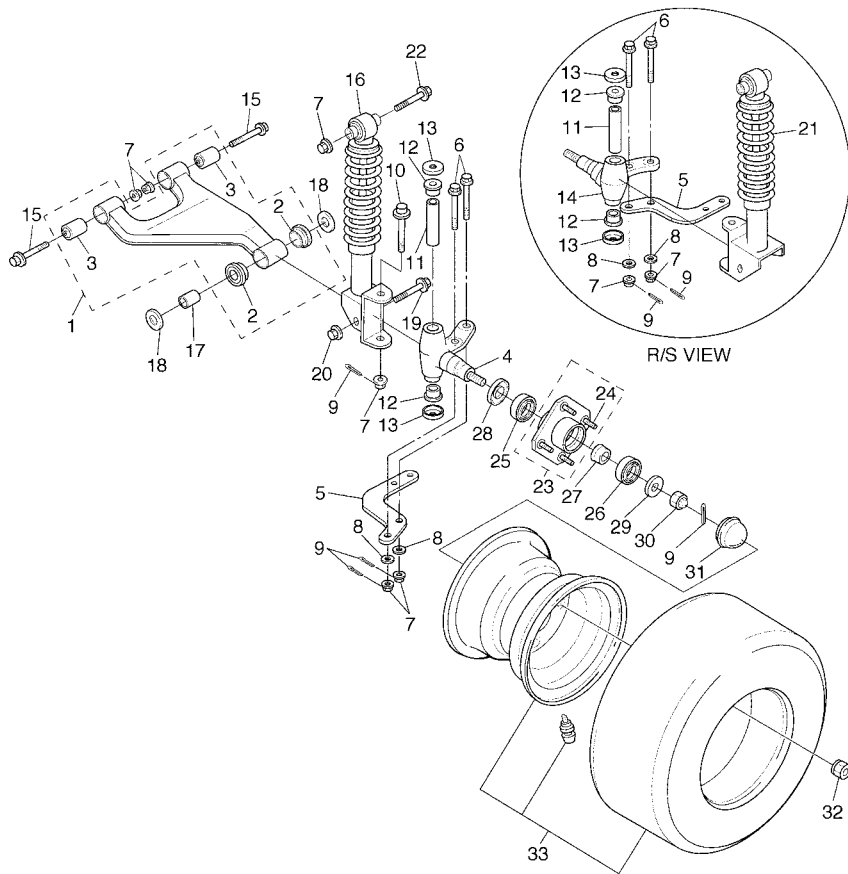
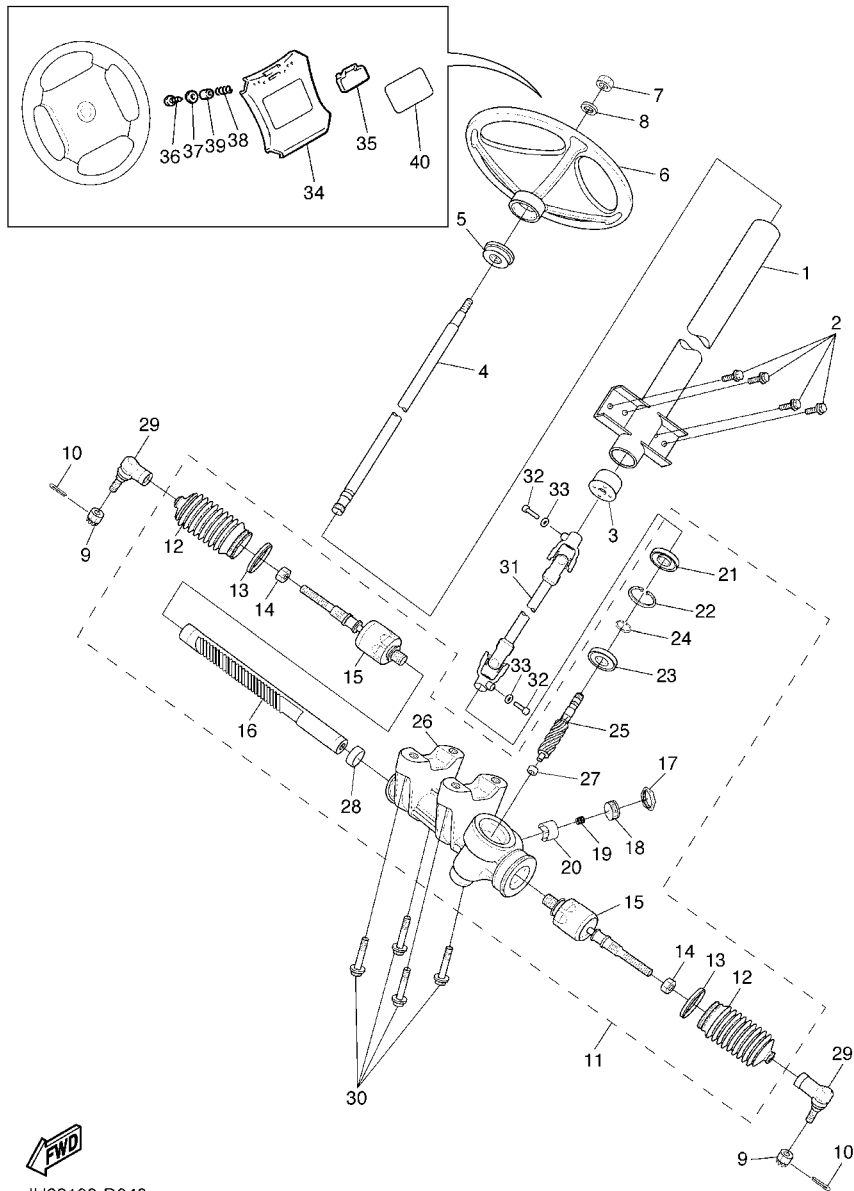

FIG. 13 FRONT SUSPENSION & WHEEL

REF. NO.	PART NO.	DESCRIPTION	JU02				REMARKS
28	93102-30083	OIL SEAL	2				
29	90209-32832	WASHER	2				
30	95607-14100	NUT, U	2				
31	JN6-F5118-00	COVER, HUB DUST	2				
32	90179-12262	NUT	8				
33	JN6-F5100-11	WHEEL ASSY (18X8.5-8 4PLY)	2				UR KENDA
	JU0-F5100-00	WHEEL ASSY (18X8.5-8 4PR)	2				UR MAXXIS PRORIDE



JT73010-C120



JU22100-D040

FIG. 14 STEERING

REF. NO.	PART NO.	DESCRIPTION	JU02				REMARKS
1	JU0-F3811-00	COLUMN, STEERING	1				
2	9581P-08016	BOLT, FLANGE	4				
3	JU0-F3857-00	HOLDER	1				
4	JU0-F3828-00	ROD, STEERING	1				
5	JN3-F3814-00	HOLDER, HANDLE UPPER	1				
6	JN3-F3838-00	WHEEL, STEERING	1				
7	90185-12061	NUT, SELF-LOCKING	1				
8	9290P-12200	WASHER	1				
9	95607-12200	NUT, SELF-LOCKING	2				
10	91401-25020	PIN, COTTER	2				
11	JU0-F3400-00	STEERING ASSY	1				
12	JU0-F3848-00	.BOOT	2				
13	JU0-F1338-00	.CLAMP	2				
14	JU0-F3833-00	.NUT 1	2				
15	JU0-F3837-00	.ROD, TIE 2	2				
16	JU0-F387E-00	.GEAR, RACK	1				
17	JU0-F3834-00	.NUT 2	1				
18	JU0-F387G-00	.COVER, ADJUST	1				
19	JU0-F387K-00	.SPRING, PRESSURE	1				
20	JU0-F387F-00	.PAD, PRESSURE	1				
21	JU0-F3844-00	.SEAL	1				
22	JU0-F387J-00	.RING, STOPPER	1				
23	JU0-F339Y-00	.BEARING	1				
24	JU0-F3183-00	.CIRCLIP	1				
25	JU0-F387A-00	.GEAR, PINION	1				
26	JU0-F2966-00	.HOUSING, MAIN 1	1				
27	JU0-F582M-00	.BEARING	1				

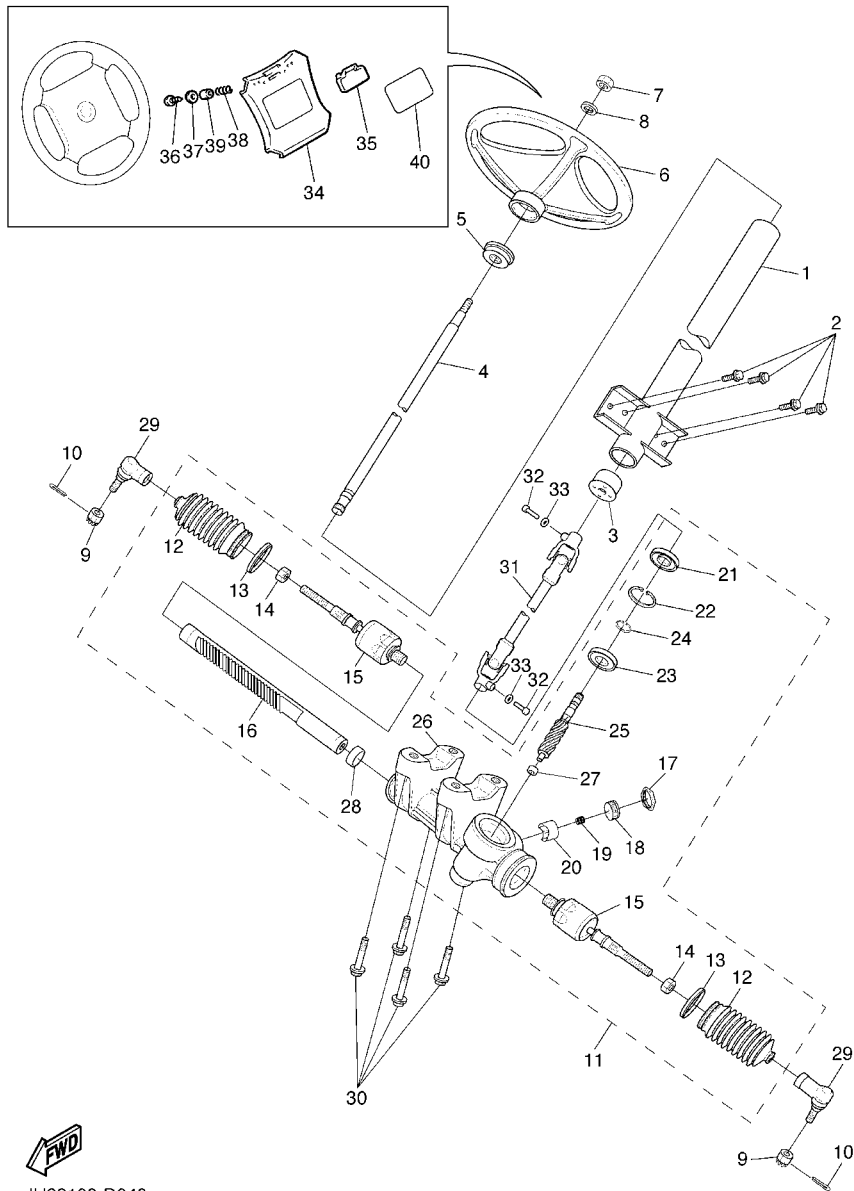

JU22100-D040

FIG. 14 STEERING

REF. NO.	PART NO.	DESCRIPTION	JU02				REMARKS
28	JU0-F5418-00	.BEARING, INSERT 1	1				
29	JU0-F3841-00	JOINT, UNIVERSAL 1	2				
30	90105-10810	BOLT, FLANGE	4				
31	JU0-F3822-00	JOINT 1	1				
32	97017-08030	BOLT	2				
33	92907-08600	WASHER, PLATE	2				
34	JN3-K8357-00	HOLDER 1	1				
35	JN6-K8358-01	HOLDER 2	1				
36	97707-40525	SCREW, TAPPING	2				
37	90201-048R5	WASHER, PLATE	2				
38	90502-10013	SPRING, CONICAL	2				
39	90387-046N7	COLLAR	2				
40	JU0-K7762-00	LABEL, WARNING 2 (E)	1				UR FOR USA,CAN
	JU0-K7762-10	LABEL, WARNING 2 (E,F)	1				UR EXCEPT USA,CAN
	JU0-K7762-20	LABEL, WARNING 2 (G,S)	1				UR EXCEPT USA,CAN

FIG. 15 FUEL TANK

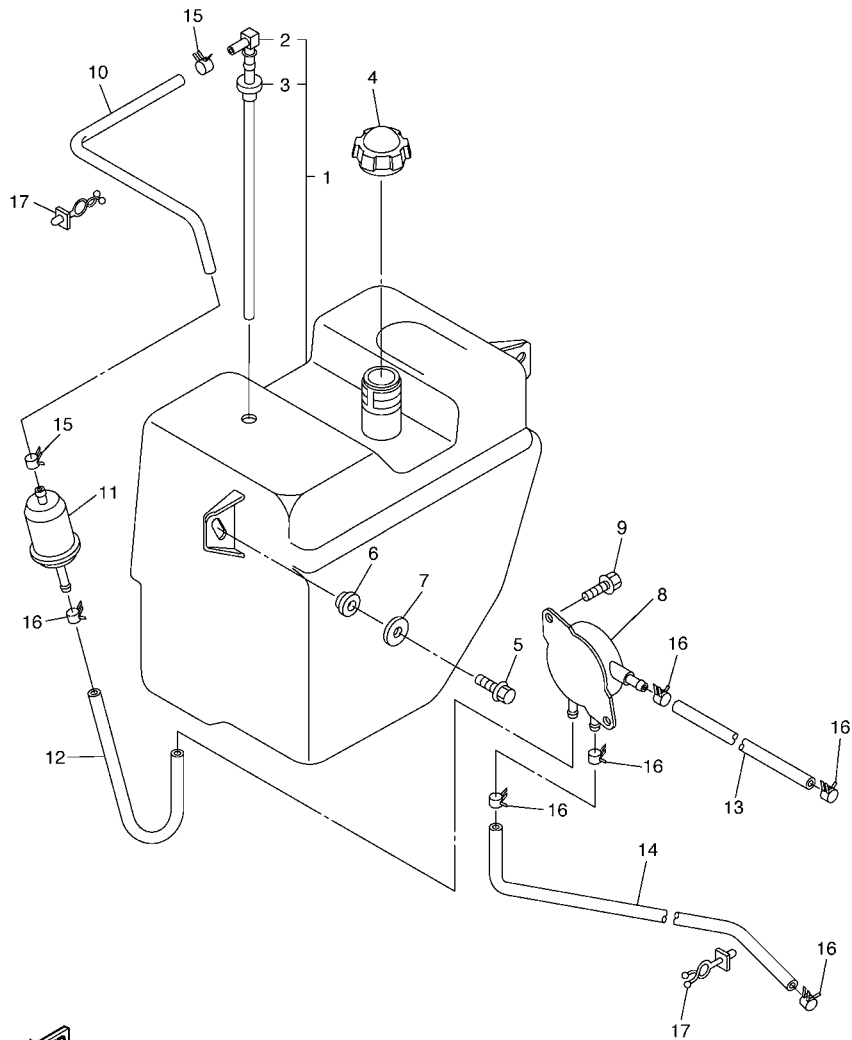

JU02100-D150

REF. NO.	PART NO.	DESCRIPTION	JU02				REMARKS
1	JU0-F4111-00	TANK, FUEL	1				
2	JU0-F4300-00	.FUEL PIPE JOINT	1				
3	JU5-F4375-00	.GROMMET	1				
4	JN6-F4610-00	CAP ASSY	1				
5	90105-08878	BOLT, FLANGE	2				
6	90560-08251	SPACER	2				
7	90201-088S2	WASHER, PLATE	2				
8	JN6-F4410-10	FUEL PUMP ASSY	1				
9	JN6-F3394-00	BOLT, SPECIAL	2				
10	JN6-F4312-20	PIPE 2	1				
11	JN6-F4560-00	FILTER ASSY	1				
12	JN6-F4311-20	PIPE, FUEL 1	1				
13	JN6-F4313-20	PIPE 3	1				
14	JN6-F4314-20	PIPE 4	1				
15	90467-12845	CLIP	2				
16	90467-10846	CLIP	6				
17	90464-11816	CLAMP	2				

FIG. 16 BRAKE

REF. NO.	PART NO.	DESCRIPTION	JU02				REMARKS
1	J46-27250-03	BRAKE ARM COMP.	1				
2	90384-14080	.BUSH, BIMETAL FORMED	2				
3	JU0-27211-01	PEDAL, BRAKE	1				
4	JU0-25671-00	PEDAL, PARKING BRAKE	1				
5	90387-08014	COLLAR	1				
6	90387-08013	COLLAR	1				
7	97027-06035	BOLT	1				
8	90179-07564	NUT	1				
9	97027-08100	BOLT	1				
10	95307-08600	NUT	1				
11	92907-08200	WASHER	1				
12	J17-25666-02	SECTOR, PARKING BRAKE	1				
13	90384-10162	BUSH, BIMETAL FORMED	1				
14	J17-27221-00	SEAL, SHAFT	2				
15	92907-10600	WASHER, PLATE	1				
16	99001-07600	CIRCLIP	1				
17	90508-14548	SPRING, TORSION	1				
18	J17-25672-01	PAD, PARKING PEDAL	1				
19	J17-27231-03	ROD, BRAKE	1				
20	J17-27232-00	END, ROD 2	1				
21	95307-06700	NUT	2				
22	90506-09001	SPRING, TENSION	1				
23	J17-25673-00	DAMPER, BRAKE	1				
24	J17-27228-00	PIN, JOINT	1				
25	92907-05600	WASHER, PLATE	1				
26	99002-04600	CIRCLIP	1				
27	90387-12009	COLLAR	3				

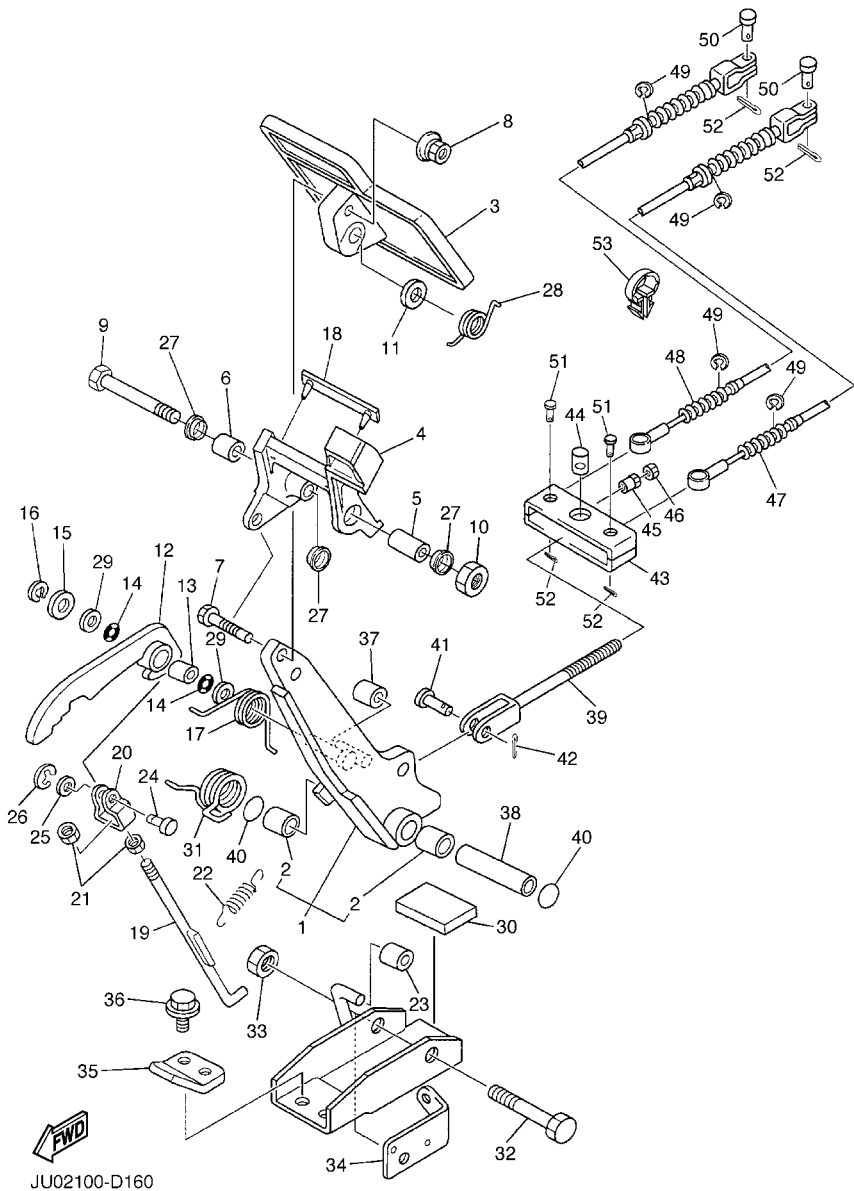

FIG. 16 BRAKE

REF. NO.	PART NO.	DESCRIPTION	JU02				REMARKS
28	90508-32015	SPRING, TORSION	1				
29	90201-104G8	WASHER, PLATE	2				
30	JN3-F7245-00	PAD, BRAKE PEDAL	1				
31	90508-40007	SPRING, TORSION	1				
32	90101-10884	BOLT	1				
33	95607-10200	NUT, U FLANGE	1				
34	J55-2252M-00	BRACKET, 3	1				
35	J17-27246-00	NAIL, BRAKE	1				
36	90105-08878	BOLT, FLANGE	2				
37	J17-25673-00	DAMPER, BRAKE	1				
38	90387-107F8	COLLAR	1				
39	JN6-F5685-00	ROD	1				
40	93210-132A8	O-RING	2				
41	91701-10022	PIN, CLEVIS	1				
42	91490-30015	PIN, COTTER	1				
43	JN6-F5681-00	EQUALIZER, BRAKE	1				
44	90249-14129	PIN	1				
45	90179-08894	NUT	1				
46	95307-08700	NUT	1				
47	JU0-F6341-00	CABLE, BRAKE	1				
48	JU0-F6351-00	CABLE, BRAKE	1				
49	99001-09600	CIRCLIP	4				
50	91701-08018	PIN, CLEVIS	2				
51	91701-08026	PIN, CLEVIS	2				
52	91490-25015	PIN, COTTER	4				
53	90464-19815	CLAMP	1				

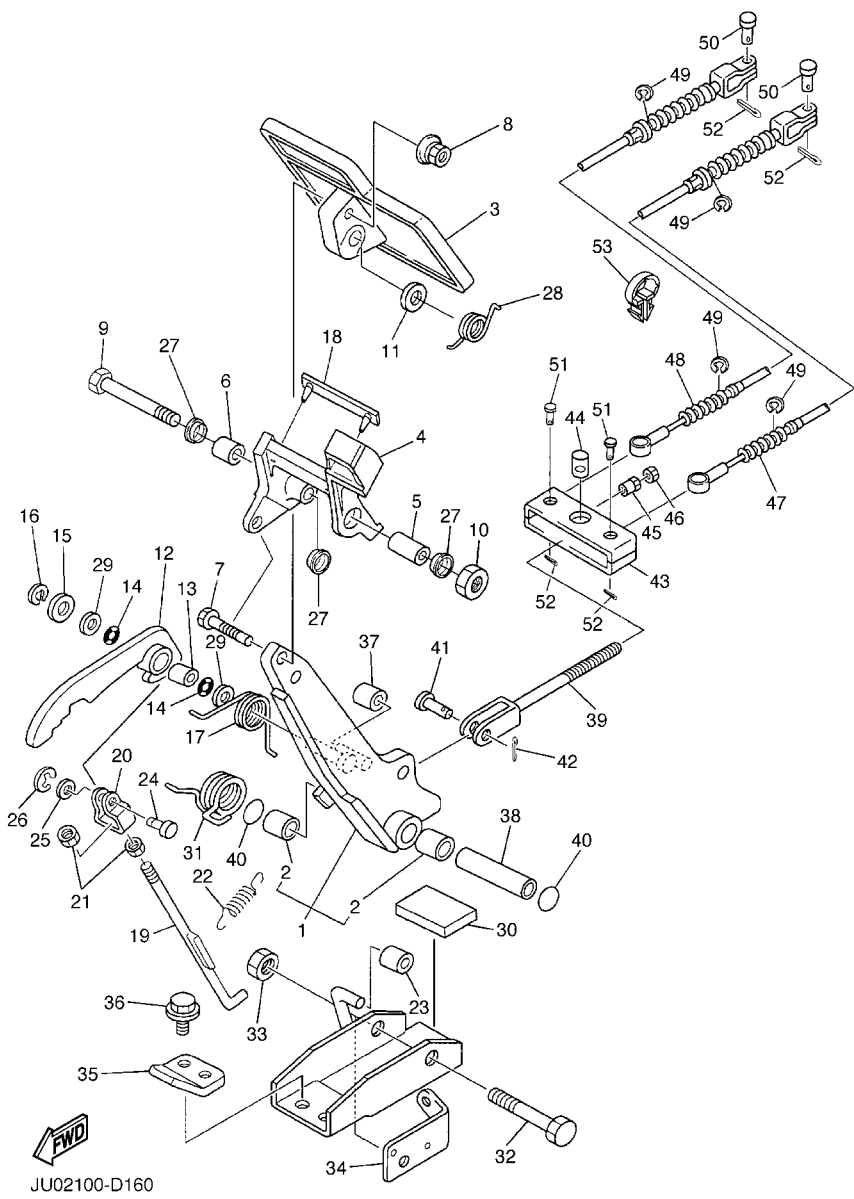
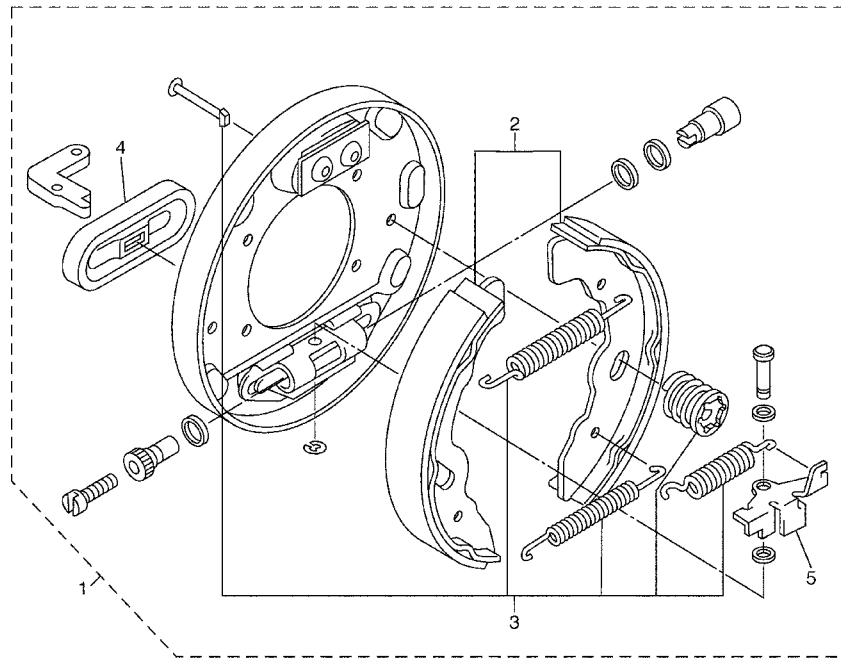

FIG. 17 BRAKE 2



REF. NO.	PART NO.	DESCRIPTION	JU02				REMARKS
1	JN6-F7290-03	BACKING PLATE ASSY 2	1				(L.H)
2	JN6-F5331-01	.SHOE, BRAKE 1	1				
3	JN6-F819G-00	.REPAIR PARTS KIT	1				
4	JN6-F7286-00	.COVER, DUST	1				
5	JN6-F722E-00	.LEVER, ADJUSTOR (LH)	1				



JT71010-B161

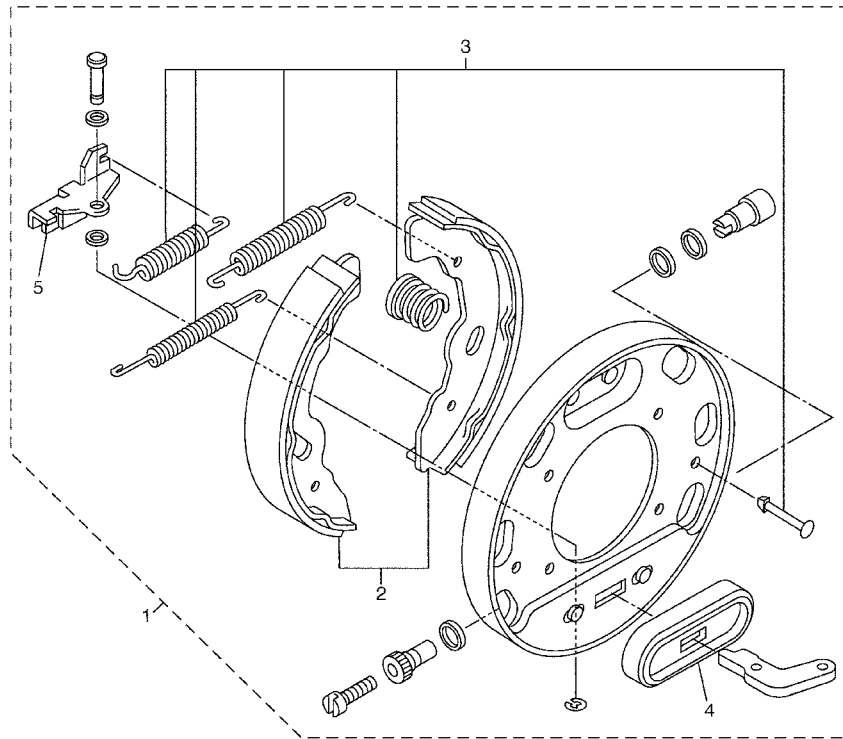
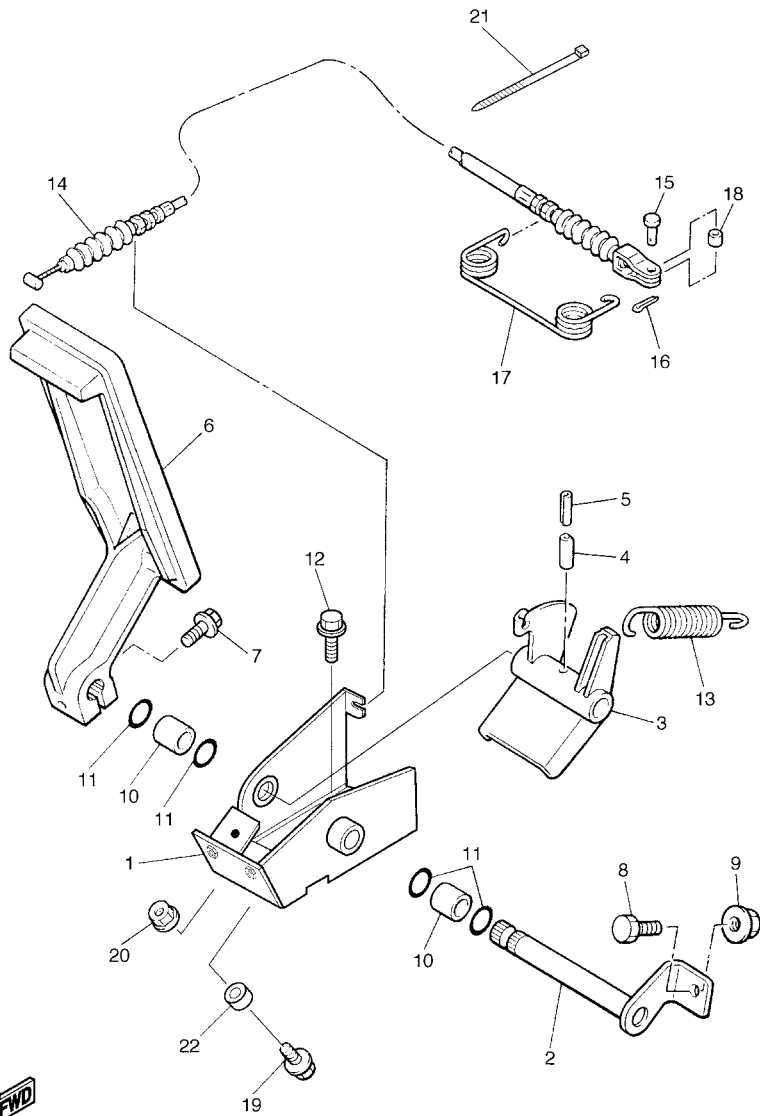

FIG. 18 BRAKE 3

REF. NO.	PART NO.	DESCRIPTION	JU02				REMARKS
1	JN6-F7280-03	BACKING PLATE ASSY 1	1				(R.H)
2	JN6-F5341-01	.SHOE, BRAKE 2	1				
3	JN6-F819G-00	.REPAIR PARTS KIT	1				
4	JN6-F7286-00	.COVER, DUST	1				
5	JN6-F722F-00	.LEVER, ADJUSTOR (RH)	1				



JT71010-B171



JT71010-B180

FIG. 19 ACCELERATOR

REF. NO.	PART NO.	DESCRIPTION	JU02				REMARKS
1	JN6-F7874-01	BRACKET, ACCELERATOR PEDAL	1				
2	J17-27853-01	SHAFT, PEDAL 1	1				
3	J38-27872-00	ARM, ACCELERATOR PEDAL	1				
4	91609-60028	PIN, SPRING	1				
5	91609-35028	PIN, SPRING	1				
6	J10-27871-01	PEDAL, ACCELERATOR	1				
7	95807-06025	BOLT, FLANGE	1				
8	90106-08806	BOLT	1				
9	95707-08500	NUT, FLANGE	1				
10	90384-14080	BUSH, BIMETAL FORMED	2				
11	93210-14104	O-RING	4				
12	90105-08878	BOLT, FLANGE	3				
13	90506-26282	SPRING, TENSION	1				
14	JN3-F6311-00	CABLE, THROTTLE 1	1				S/N ~ 214820
	JU0-F6311-00	CABLE, THROTTLE 1	1				S/N 214821 ~
15	91701-05012	PIN, CLEVIS	1				S/N ~ 214820
	91701-05014	PIN, CLEVIS	1				S/N 214821 ~
16	90468-10049	CLIP	1				
17	90508-16460	SPRING, TORSION	1				
18	90560-05001	SPACER	1				
19	95807-06025	BOLT, FLANGE	1				
20	95707-06500	NUT, FLANGE	1				
21	90464-40825	CLAMP	2				
22	90387-068T4	COLLAR	1				

FIG. 20 GOVERNOR

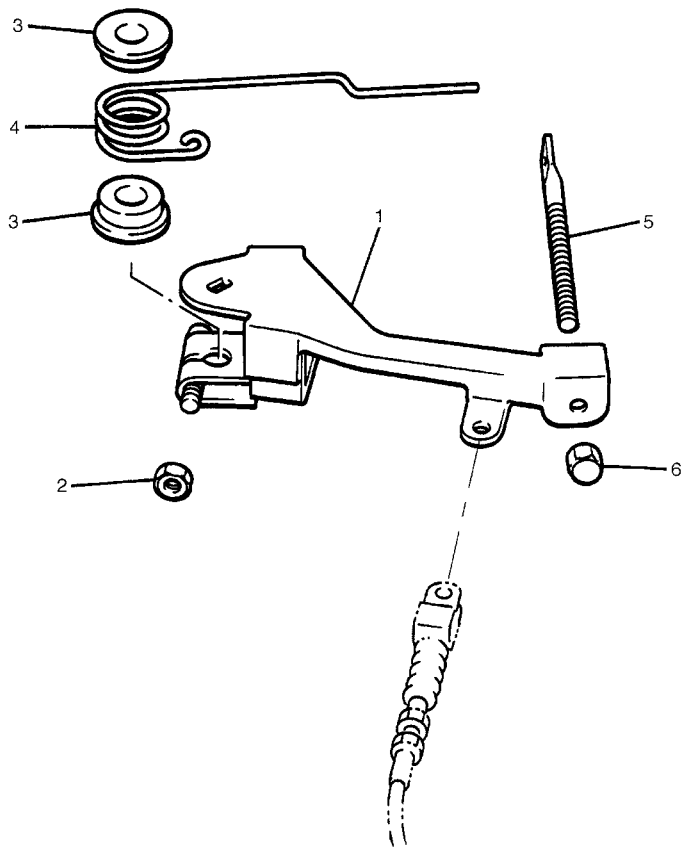

REF. NO.	PART NO.	DESCRIPTION	JU02				REMARKS
1	J38-27951-00	LEVER, SPEED LIMITER	1				
2	95307-06600	NUT	1				
3	90386-08141	BUSH	2				
4	90508-40678	SPRING, TORSION	1				
5	J38-27959-00	SCREW, ADJUSTING	1				
6	9560P-06200	NUT, FLANGE	1				

JT71010-B190

C10

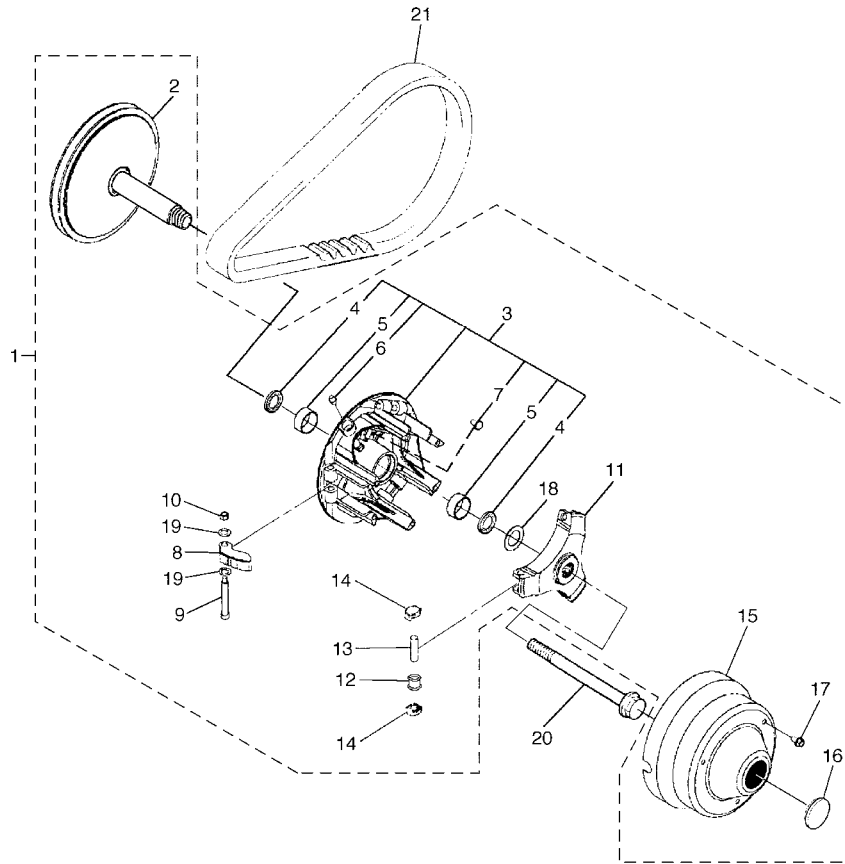

FIG. 21 PRIMARY SHEAVE

REF. NO.	PART NO.	DESCRIPTION	JU02				REMARKS
1	JN6-G6201-04	PRIMARY FIXED SHEAVE ASSY	1				
2	JN6-G6210-00	.PRIMARY FIXED SHEAVE COMP.	1				
3	JN6-G6220-00	.PRIMARY SLIDING SHEAVE COMP.	1				
4	93101-28831	..OIL SEAL	2				
5	90384-27823	..BUSH, BIMETAL FORMED	2				
6	93700-06810	..NIPPLE, GREASE	1				
7	90338-04840	..PLUG	3				
8	JN6-G6232-01	.WEIGHT 1	3				
9	90109-06860	.BOLT	3				
10	90185-06834	.NUT, SELF-LOCKING	3				
11	JN6-G6251-01	.SPIDER	1				
12	JN6-G6258-02	.COLLAR, ROLLER	3				
13	93610-358A3	.PIN, DOWEL	3				
14	JN6-G6253-00	.SLIDER	6				
15	JU0-G6231-00	.CAP	1				
16	JU0-G6297-00	.COVER, DUST	1				
17	90105-06861	.BOLT, FLANGE	3				
18	90201-228K5	.WASHER, PLATE	1				
19	JN6-G621F-00	.SHIM, THRUST	6				
20	JN6-G6249-00	BOLT	1				
21	J55-G6241-00	V-BELT	1				



JT71010-B200

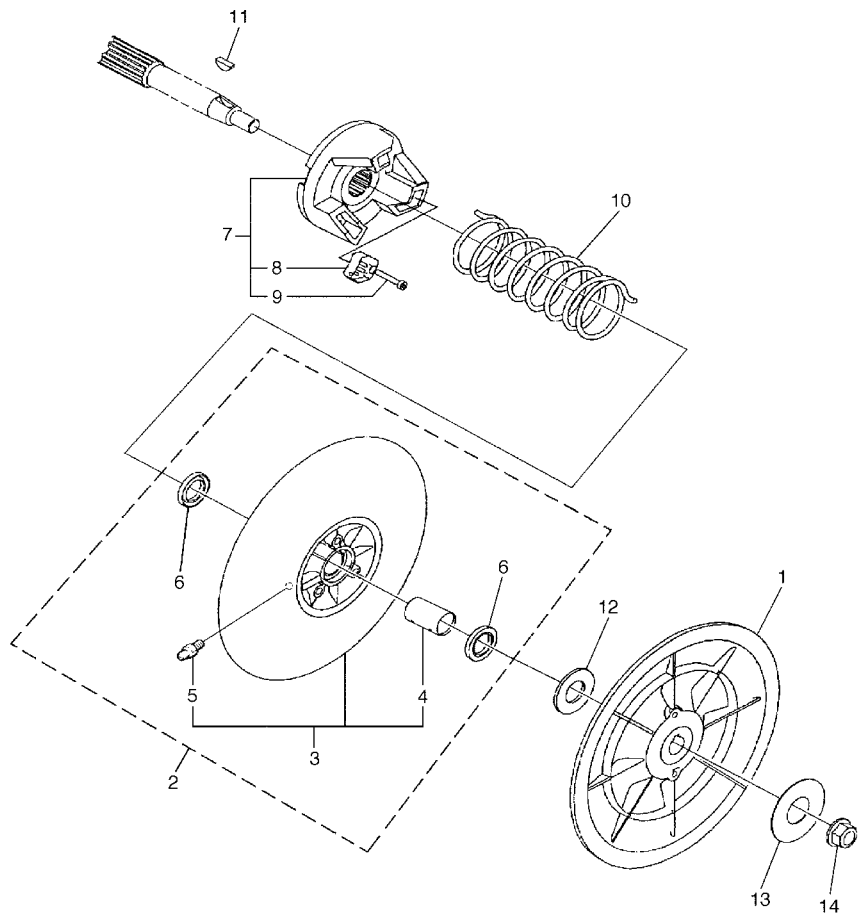

FIG. 22 SECONDARY SHEAVE

REF. NO.	PART NO.	DESCRIPTION	JU02				REMARKS
1	JN6-G6260-00	SECONDARY FIXED SHEAVE COMP.	1				
2	JN6-G6270-01	SECONDARY SLIDING SHEAVE COMP.	1				
3	JN6-G6271-02	.SECONDARY SLIDING SHEAVE	1				
4	90384-20824	..BUSH, BIMETAL FORMED	1				
5	93700-06809	..NIPPLE, GREASE	1				
6	93109-20069	.OIL SEAL	2				
7	JN6-G6280-00	SECONDARY SPRING SEAT COMP.	1				
8	JN6-E7688-00	.SHOE, RAMP	3				
9	90110-04834	.BOLT, HEXAGON SOCKET HEAD	3				
10	90508-45844	SPRING, TORSION	1				
11	90280-05022	KEY, WOODRUFF	1				
12	90202-20130	WASHER, PLATE	1				
13	90201-128S5	WASHER, PLATE	1				
14	95607-12200	NUT, SELF-LOCKING	1				



JT71010-B210

FIG. 23 TRANSMISSION 1

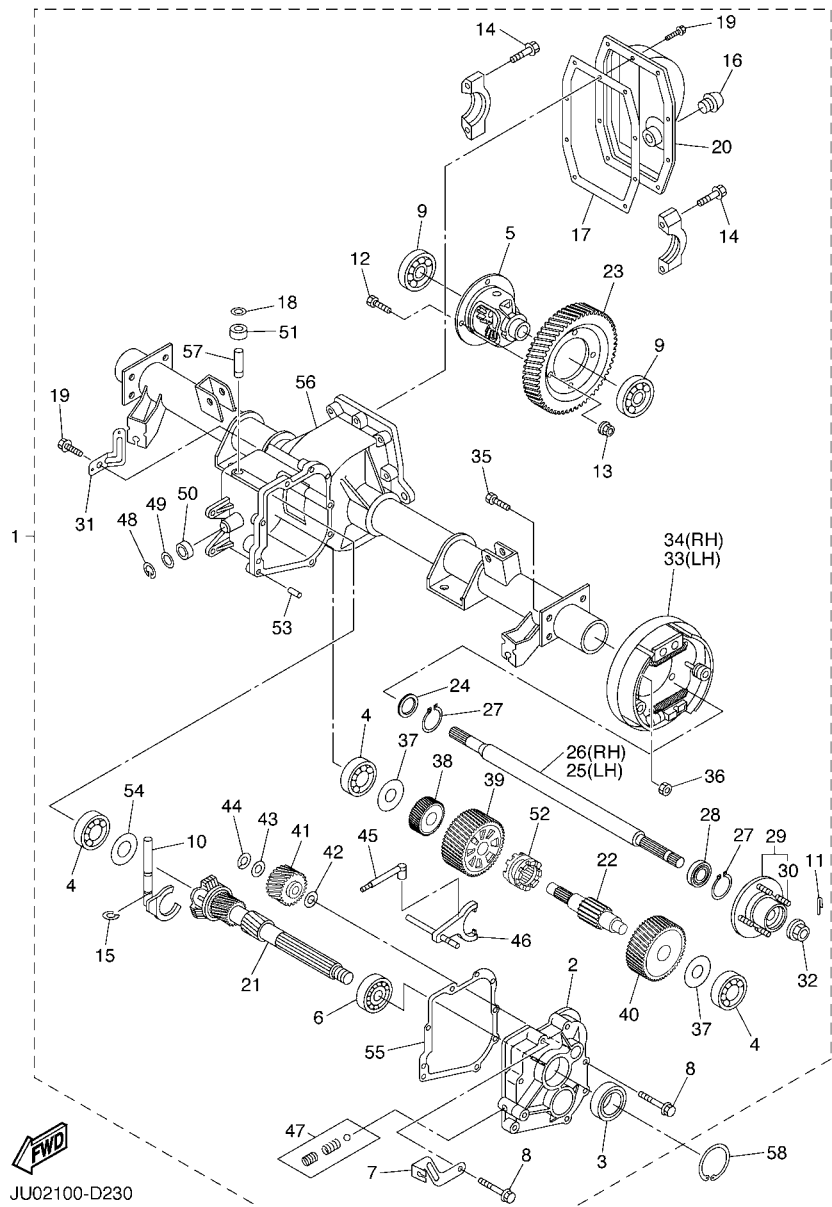

JU02100-D230

REF. NO.	PART NO.	DESCRIPTION	JU02				REMARKS
1	JU0-G6300-10	TRANS AXLE ASSY	1				
2	JN3-G6313-00	.COVER, TRNSMISSION	1				
3	93102-25868	.OIL SEAL	1				
4	93306-303Y6	.BEARING	3				
5	JN6-G6410-00	.DIFFERENTIAL ASSY.	1				
6	93306-005Y4	.BEARING	1				
7	JN6-G6555-00	.BRACKET 2	1				
8	90105-08859	.BOLT, FLANGE	7				
9	93306-007Y0	.BEARING	2				
10	JN3-G633E-01	.BAR 1	1				
11	91490-25025	.PIN, COTTER	2				
12	90101-10854	.BOLT	4				
13	90170-10840	.NUT	4				
14	90105-10840	.BOLT, FLANGE	4				
15	JU0-F722H-00	.RETAINER	1				
16	JN3-G6432-00	.STOPPER	1				
17	JU0-G631A-00	.GSKT., CASE	1				
18	JU0-F723F-00	.WASHER, SPECIAL	1				
19	90101-08856	.BOLT	11				
20	JN3-G6314-00	.COVER, TRANSMISSION	1				
21	JN3-G6320-01	.INPUT SHAFT ASSY	1				
22	JN3-G633G-00	.SHAFT	1				
23	JN3-G6355-00	.GEAR, PRIMARY	1				
24	93101-24822	.OIL SEAL	2				
25	JN3-G6511-00	.SHAFT, REAR AXLE 1 (L.H)	1				
26	JN3-G6512-00	.SHAFT, REAR AXLE 2 (R.H)	1				
27	93420-44805	.CIRCLIP	4				

FIG. 23 TRANSMISSION 1

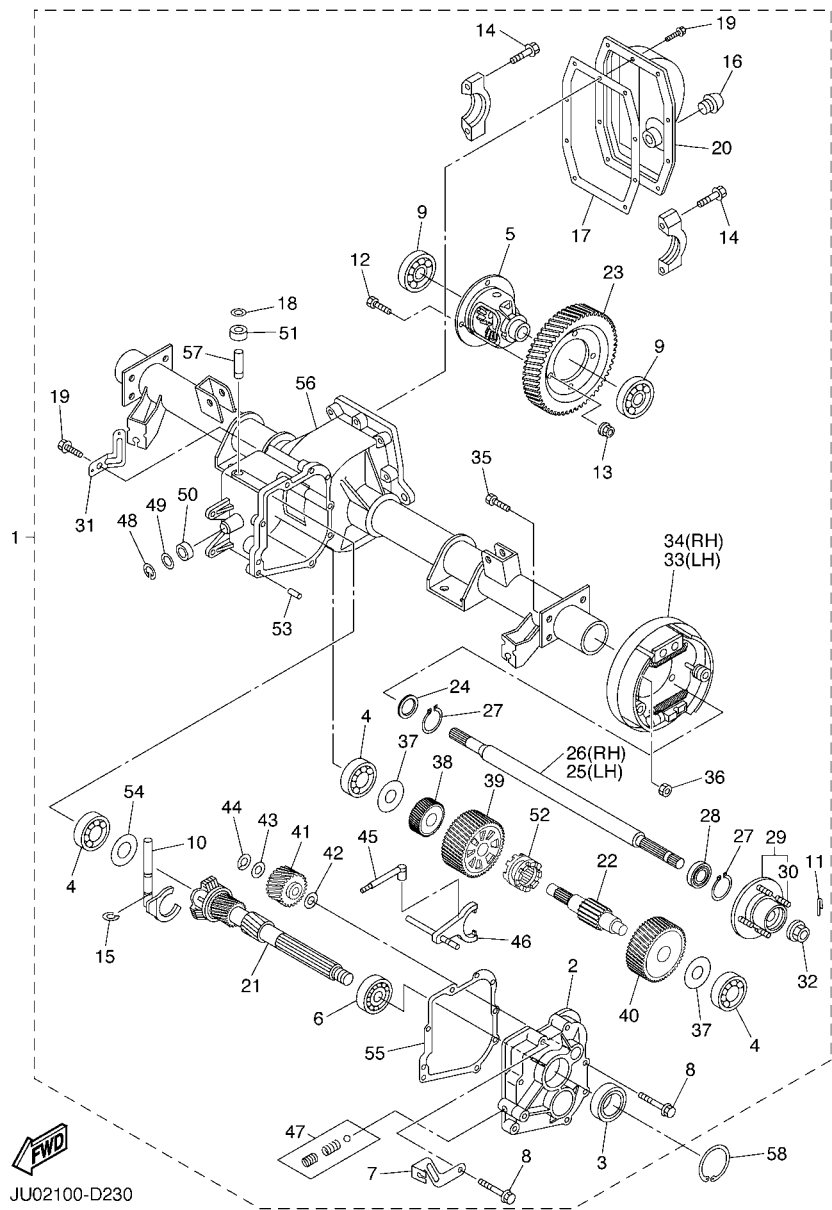

JU02100-D230

REF. NO.	PART NO.	DESCRIPTION	JU02				REMARKS
28	93306-004X5	.BEARING	2				
29	JN3-G6514-00	.HUB, REAR AXLE	2				
30	90114-12804	.BOLT, SERRATION	4				
31	JN3-G6556-00	.BRACKET 3	1				
32	90185-16833	.NUT, SELF-LOCKING	2				
33	JN6-F7290-03	.BACKING PLATE ASSY 2	1				SEE FIG.17(L.H)
34	JN6-F7280-03	.BACKING PLATE ASSY 1	1				SEE FIG.18(R.H)
35	90101-08855	.BOLT	8				
36	90170-08841	.NUT	8				
37	90201-178H8	.WASHER, PLATE	2				
38	JN3-G6316-00	.GEAR, PINION 1	1				
39	JN3-G6326-00	.GEAR, WHEEL 1	1				
40	JN3-G6327-00	.GEAR, WHEEL 2	1				
41	JN3-G6356-00	.GEAR, IDLER	1				
42	90201-208H9	.WASHER, PLATE	1				
43	90201-208J0	.WASHER, PLATE	1				
44	93440-20813	.CIRCLIP	1				
45	JN3-G638A-00	.BAR, SHIFT 1	1				
46	JN6-G638E-00	.BAR, SHIFT 2	1				
47	JU0-G6376-00	.SPRING SET	1				
48	93410-12822	.CIRCLIP	1				
49	90202-12807	.WASHER, PLATE	1				
50	93104-11829	.OIL SEAL	1				
51	93109-10820	.OIL SEAL	1				
52	JN3-G6153-00	.COLLAR, GUIDE	1				
53	93606-10842	.PIN, DOWEL	2				
54	JN3-G6344-00	.SHIM, 0.76MM (0.030IN)	1				UR

FIG. 23 TRANSMISSION 1

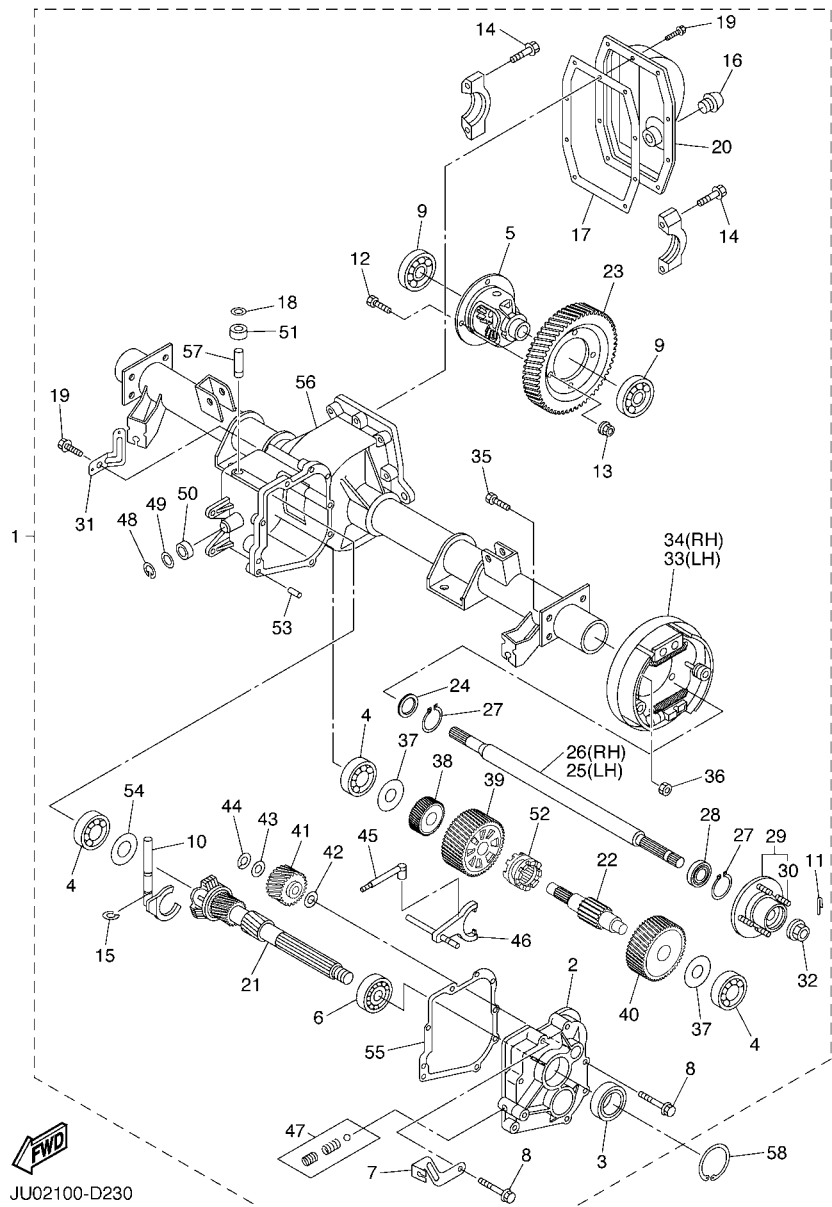

JU02100-D230

REF. NO.	PART NO.	DESCRIPTION	JU02				REMARKS
54	JN3-G6344-10	.SHIM, 0.90MM (0.035IN)	1				UR
	JN3-G6344-20	.SHIM, 1.00MM (0.040IN)	1				UR
	JN3-G6344-30	.SHIM, 1.14MM (0.045IN)	1				UR
	JN3-G6344-40	.SHIM, 1.27MM (0.050IN)	1				UR
	JN3-G6344-50	.SHIM, 1.39MM (0.055IN)	1				UR
	JN3-G6344-60	.SHIM, 1.52MM (0.060IN)	1				UR
	JN3-G6344-70	.SHIM, 1.65MM (0.065IN)	1				UR
	JN3-G6344-80	.SHIM, 0.38MM (0.015IN)	1				UR
	JN3-G6344-90	.SHIM, 1.78MM (0.070IN)	1				UR
	JN3-G6344-A0	.SHIM, 1.92MM (0.075IN)	1				UR
	JN3-G6344-B0	.SHIM, 2.03MM (0.080IN)	1				UR
	JN3-G6344-C0	.SHIM, 2.12MM (0.085IN)	1				UR
	JN3-G6344-D0	.SHIM, 2.29MM (0.090IN)	1				UR
55	JN3-G6319-00	.GASKET	1				
56	JU0-G6290-00	.CASEASSY	1				
57	JU0-G6164-00	.BEARING 1	1				
58	93410-25017	CIRCLIP	1				

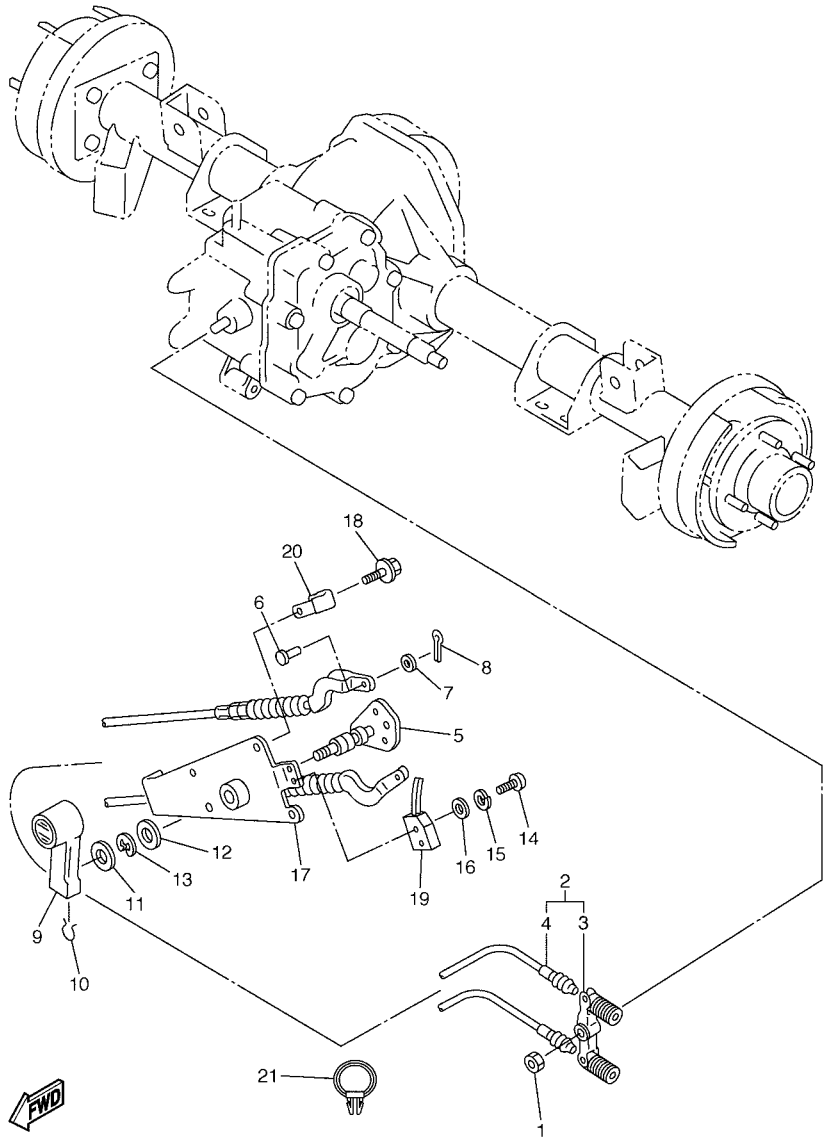

JT71010-B240

FIG. 25 SHIFTER & CABLES

REF. NO.	PART NO.	DESCRIPTION	JU02				REMARKS
1	95607-08100	NUT, U	1				
2	JN3-G8330-00	CABLE END ASSY	1				
3	J55-G6383-00	.LEVER, SHIFT 2	1				
4	JN3-G6371-00	.WIRE, SHIFT	2				
5	JF2-46382-00	LEVER, SHIFT 1	1				
6	91701-06014	PIN, CLEVIS	2				
7	9290P-06600	WASHER	2				
8	91401-20012	PIN, COTTER	2				
9	JN3-G6381-00	KNOB, SHIFT	1				
10	JN3-G6376-00	SPRING SET	1				
11	90201-208S8	WASHER, PLATE	1				
12	90201-198S7	WASHER, PLATE	1				
13	99009-19400	CIRCLIP	1				
14	98507-04016	SCREW, PAN HEAD	2				
15	92907-04100	WASHER, SPRING	2				
16	92907-04600	WASHER	2				
17	JN3-G6372-00	BRACKET, SHIFT WIRE	1				
18	90105-06876	BOLT, FLANGE	4				
19	JN3-82617-01	SWITCH	1				
20	90465-06038	CLAMP	1				
21	90464-19815	CLAMP	1				

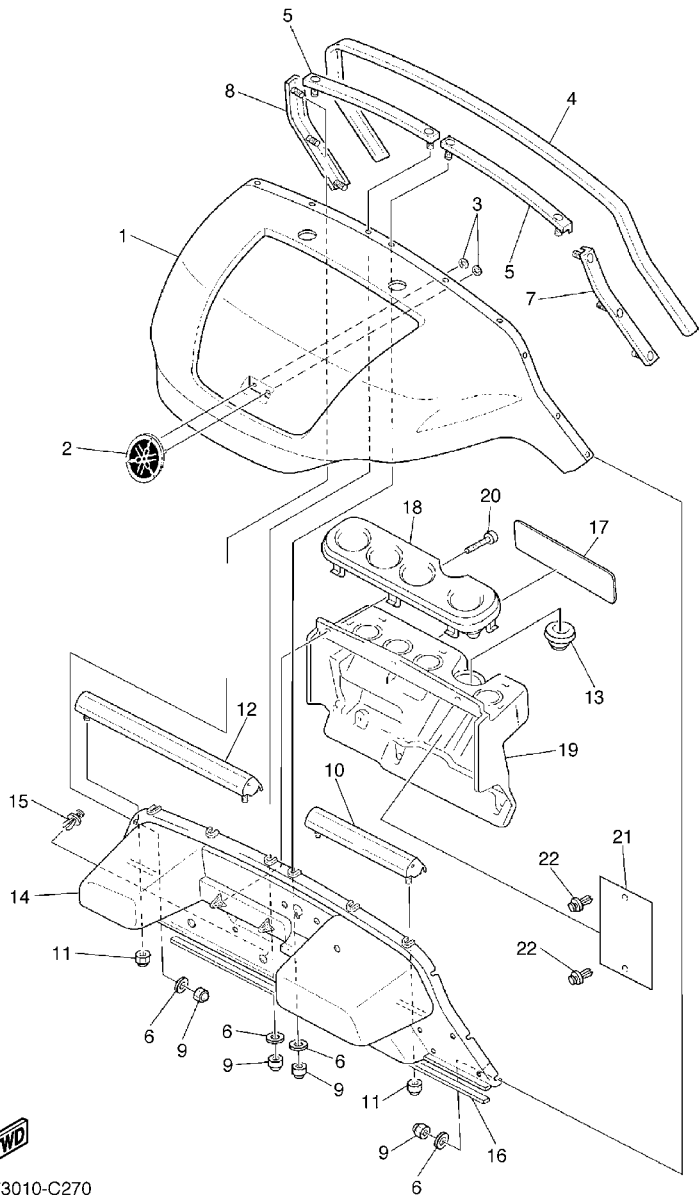

JT73010-C270

FIG. 27 BODY

REF. NO.	PART NO.	DESCRIPTION	JU02				REMARKS
1	JU0-K8115-00	COWL, FRONT	1				UR FOR VPYS2
	JU0-K8115-30	COWL, FRONT	1				UR FOR HTR
	JU0-K8115-50	COWL, FRONT	1				UR FOR VDGS1
	JU0-K8115-60	COWL, FRONT	1				UR FOR DRMG
	JU0-K8115-71	COWL, FRONT	1				UR FOR DPBMP
	JU0-K8115-80	COWL, FRONT	1				UR FOR DPBMT
2	JU0-F4161-00	EMBLEM 1	1				
3	JU0-K7573-00	NUT, SPECIAL	2				
4	JF2-K811V-00	PROTECTOR 1	1				
5	JU0-K8261-00	PLATE, BODY PROTECT 1	2				
6	90201-06829	WASHER, PLATE	10				
7	JF2-K8262-01	PLATE, BODY PROTECT 2	1				
8	JF2-K8263-01	PLATE, BODY PRTOTECT 3	1				
9	90185-06836	NUT, SELF-LOCKING	10				
10	JN6-K8264-00	PLATE, BODY PROTECT 4	1				
11	9560P-06200	NUT, FLANGE	4				
12	JN6-K8265-00	PLATE, BODY PROTECT 5	1				
13	JN3-K8273-00	COVER, HOLE	1				
14	JF2-K8114-03	PANEL, FRONT	1				
15	90269-08066	RIVET	3				
16	JN3-K815G-00	SEAL, FRONT STORAGE	1				
17	JN3-K7768-00	LABEL, WARNING 8 (E)	1				UR FOR USA,CAN
	JN3-K7768-10	LABEL, WARNING 8 (E,F)	1				UR EXCEPT USA,CAN
	JN3-K7768-20	LABEL, WARNING 8 (G,S)	1				UR EXCEPT USA,CAN
18	JN6-K835E-00	HOLDER, BEVERAGE	1				
19	JN3-K835G-00	HOUSING, HOLDER	1				
20	9770P-60130	SCREW, TAPPING	6				

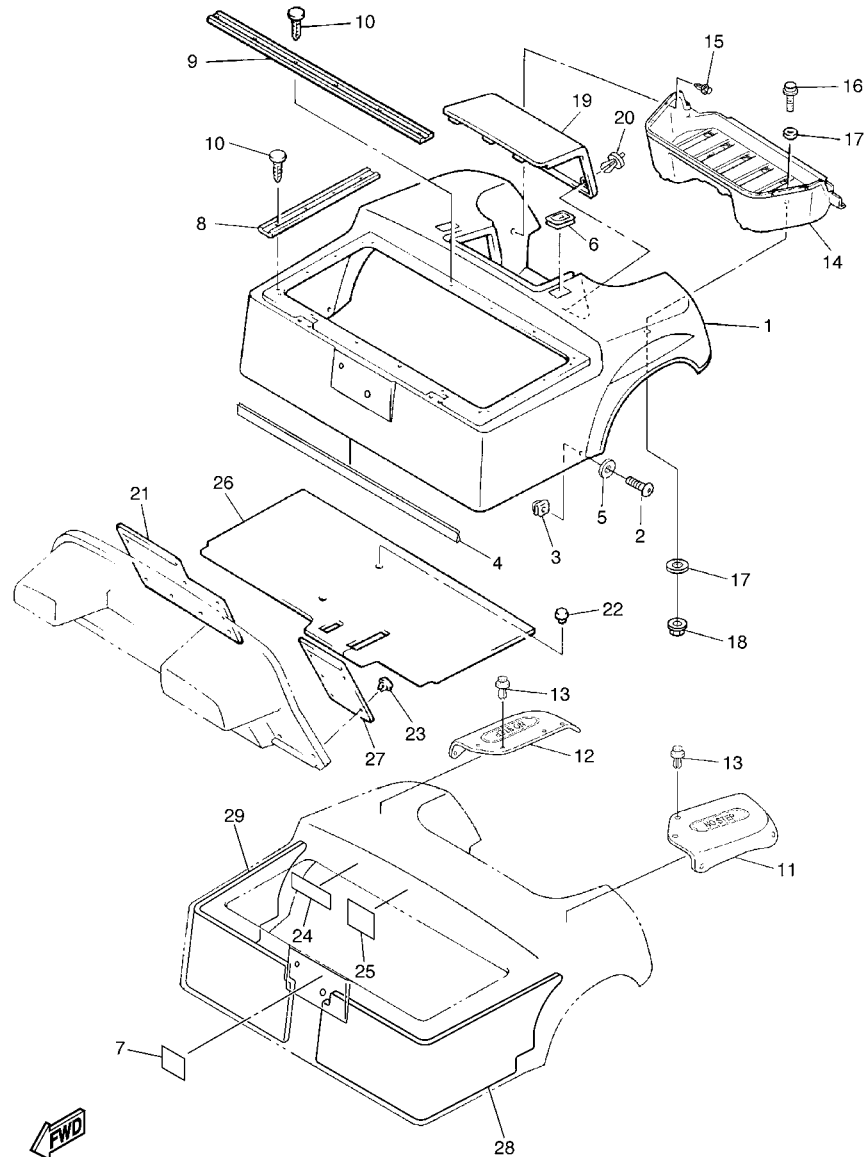

JU02100-D280

FIG. 28 BODY 2

REF. NO.	PART NO.	DESCRIPTION	JU02				REMARKS
1	JN6-K8142-02	PANEL, REAR BODY	1				UR FOR VPYS2
	JU0-K8142-32	PANEL, REAR BODY	1				UR FOR HTR
	JN6-K8142-52	PANEL, REAR BODY	1				UR FOR VDGS1
	JU0-K8142-62	PANEL, REAR BODY	1				UR FOR DRMG
	JU0-K8142-73	PANEL, REAR BODY	1				UR FOR DPBMP
	JU0-K8142-82	PANEL, REAR BODY	1				UR FOR DPBMT
2	90110-06837	BOLT, HEXAGON SOCKET HEAD	2				
3	90183-06811	NUT, SPRING	2				
4	JN6-K824E-00	TRIM, REAR BODY 1	1				
5	90201-068H0	WASHER, PLATE	2				
6	JN3-K8363-00	PROTECTOR	2				
7	JN3-K7741-00	INDICATOR 1	1				
8	JN3-K8425-00	SEAL, SEAT	2				
9	JN3-K842A-00	SEAL, SEAT 2	1				
10	90338-05834	PLUG	20				
11	JN3-K8243-00	MAT, REAR BODY SIDE (LH)	1				
12	JN3-K8244-00	MAT, REAR BODY SIDE (RH)	1				
13	90269-07810	RIVET	10				
14	JF2-K8237-00	COVER, REAR FLOOR	1				
15	90269-08813	RIVET	7				
16	90101-06876	BOLT	2				
17	90201-068G7	WASHER, PLATE	4				
18	9572R-06300	NUT, NYLON	2				
19	JU0-K8151-00	PANEL, INSPECTION LID 1	1				
20	90269-06804	RIVET	2				
21	JN6-K8232-01	MAT, MAIN FLOOR 2	1				
22	90269-08813	RIVET	4				

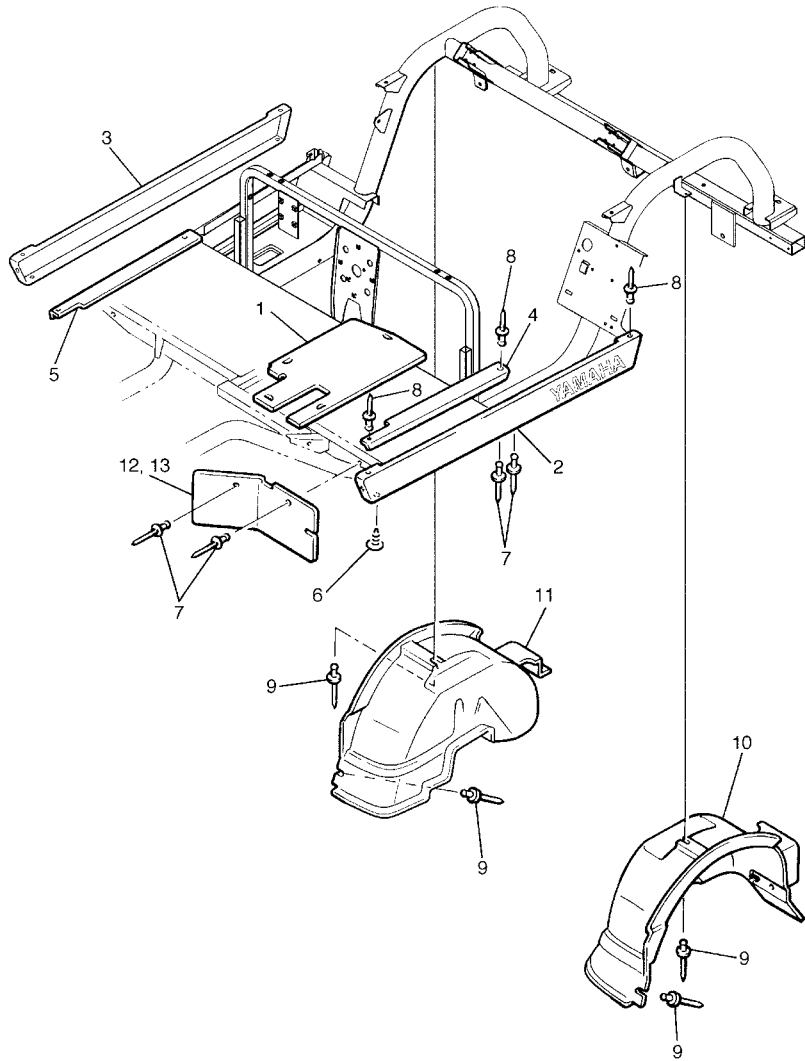
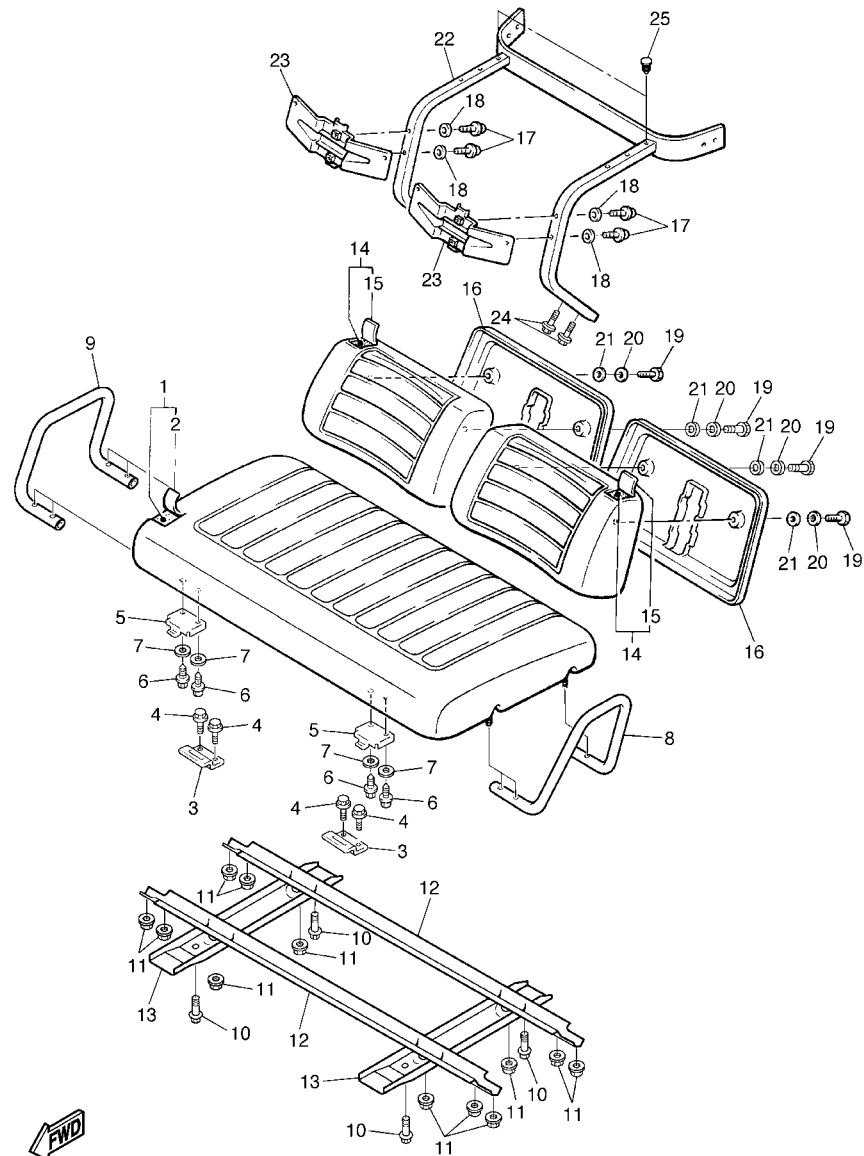

FIG. 29 BODY FITTING

REF. NO.	PART NO.	DESCRIPTION	JU02				REMARKS
1	JN6-K8271-00	SERVICE LID, PEDAL	1				
2	JU0-K818A-00	PROTECTOR, SIDE PLATE	1				
3	JU0-K818B-00	PROTECTOR, SIDE PLATE 2	1				
4	JF2-K8215-10	PLATE, SIDE TRIM	1				
5	JF2-K821F-10	PLATE, SIDE TRIM	1				
6	90338-05829	PLUG	4				
7	90267-48831	RIVET, BLIND	8				
8	90267-48154	RIVET, BLIND	6				
9	90267-48086	RIVET, BLIND	4				
10	JF2-K8191-01	PANEL, REAR FENDER 1	1				
11	JF2-K8192-01	PANEL, REAR FENDER 2	1				
12	JF2-K8187-00	FLAP, FRONT FENDER (L.H)	1				
13	JF2-K8189-00	FLAP, FRONT FENDER (R.H)	1				



JW41110-C290



JT73010-C320

FIG. 31 SEAT

REF. NO.	PART NO.	DESCRIPTION	JU02				REMARKS
1	JN6-K8401-10	SEAT SUB-ASSY,CUSHION	1				UR IVORY WHITE
	JU0-K8401-00	SEAT SUB-ASSY,CUSHION	1				UR MILKY BROWN
2	JN6-K8404-10	.COVER,SEAT	1				UR IVORY WHITE
	JU0-K8404-00	.COVER,SEAT	1				UR MILKY BROWN
3	JF2-K8427-00	HINGE, SEAT 2	2				
4	90105-06903	BOLT, FLANGE	4				
5	JN3-K8426-01	HINGE, SEAT 1	2				
6	90111-06810	BOLT	4				
7	90204-06807	WASHER, SPRING	4				
8	JN6-K8361-00	ARM REST 1	1				
9	JU0-K8362-00	ARM REST 2	1				
10	90167-04815	SCREW, TAPPING	4				
11	9560P-08200	NUT	12				
12	JN6-K8121-00	REINFORCEMENT 1	2				
13	JN6-K8122-02	REINFORCEMENT 2	2				
14	JN3-K8402-00	SEAT SUB ASSY, BACK	2				UR IVORY WHITE
	JU0-K8402-00	SEAT SUB ASSY, BACK	2				UR MILKY BROWN
15	JN3-K841G-09	.COVER, SEAT BACK 2	1				UR IVORY WHITE
	JU0-K841G-09	.COVER, SEAT BACK 2	1				UR MILKY BROWN
16	JN3-K8413-00	COVER, SEAT BACK	2				
17	90119-08820	BOLT, WITH WASHER	4				
18	90201-098J4	WASHER, PLATE	4				
19	90201-068G0	WASHER, PLATE	4				
20	95880-06025	BOLT, FLANGE	4				
21	90201-068G6	WASHER, PLATE	4				
22	JU0-K8423-00	SUPPORT, SEAT BACK	1				
23	JN3-K842H-00	RETAINER, SEAT	2				

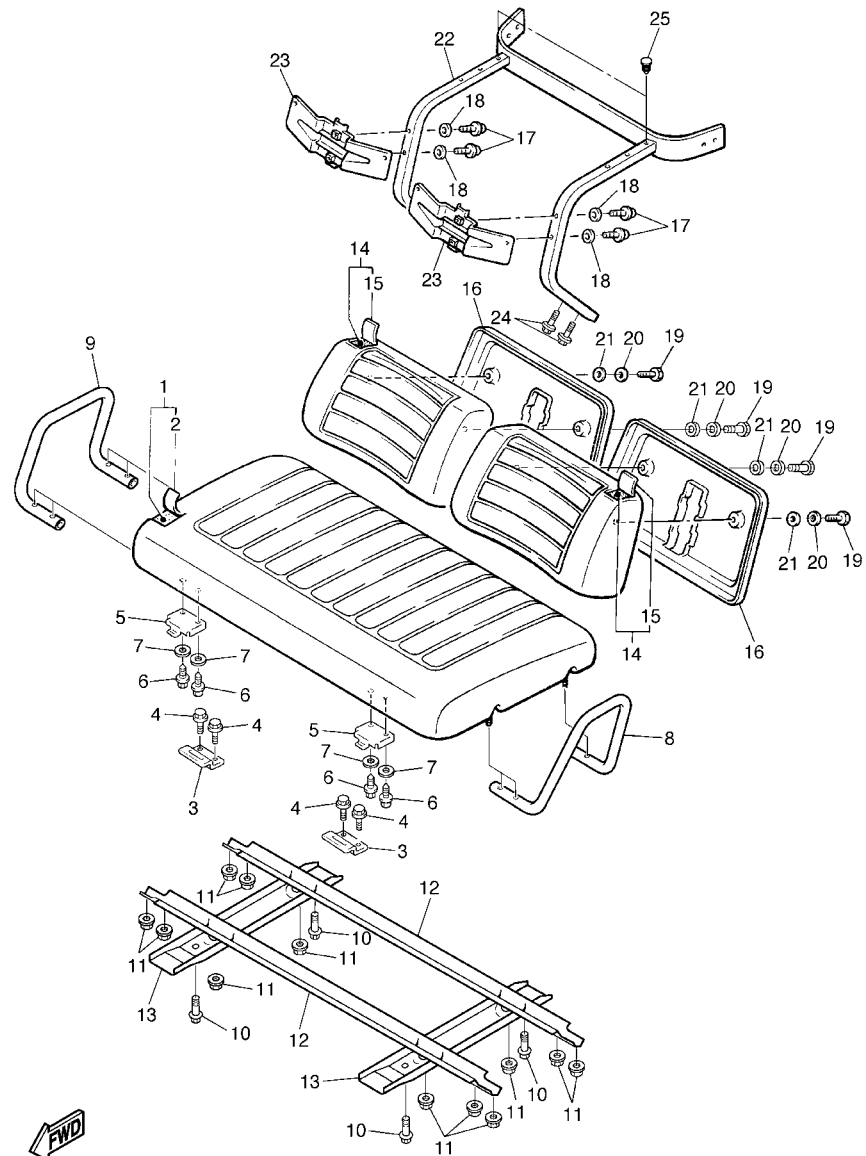

JT73010-C320

FIG. 31 SEAT

REF. NO.	PART NO.	DESCRIPTION	JU02				REMARKS
24	90105-08871	BOLT, FLANGE	4				
25	90338-09828	PLUG	2				

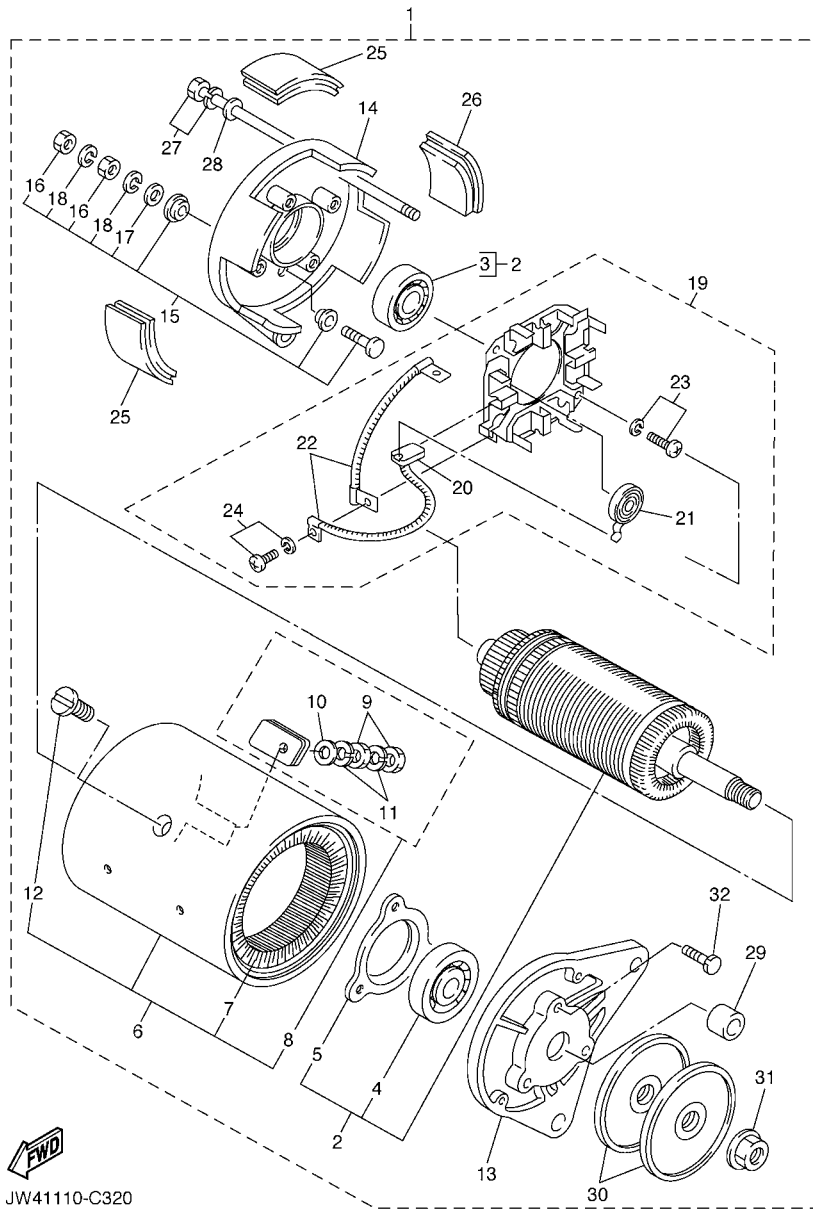

JW41110-C320

FIG. 32 STARTING MOTOR

REF. NO.	PART NO.	DESCRIPTION	JU02				REMARKS
1	JN6-H1100-03	STARTER GENERATOR ASSY	1				
2	JN3-H1150-00	.ARMATURE ASSY	1				
3	J10-H1157-10	..BEARING 1 (6202 SD)	1				
4	J10-H1158-10	..BEARING 2 (6203 SD)	1				
5	J10-H1159-10	..HOLDER, BEARING	1				
6	JN6-H1110-10	..STATOR ASSY	1				
7	JN6-H1160-10	..FIELD COIL ASSY	1				
8	J10-81148-10	..SCREW SET 4	2				
9	9530N-06600	...NUT	2				
10	9290N-06600	...WASHER	1				
11	9290N-06100	...WASHER, SPRING	2				
12	J10-H1146-10	..SCREW 2	4				
13	JN6-H1165-00	.BRACKET, STARTER GENERATOR 1	1				
14	J10-H1166-10	.BRACKET, STARTER GENERATOR 2	1				
15	J10-H1147-10	.SCREW 3	2				
16	9530N-06600	..NUT	2				
17	9290N-06600	..WASHER	1				
18	9290N-06100	..WASHER, SPRING	2				
19	JN6-H1119-00	.BRUSH HOLDER ASSY	1				
20	JF2-H1111-00	..BRUSH	4				
21	JN6-H1113-00	..SPRING, BRUSH	4				
22	J10-H1115-10	..WIRE, LEAD	2				
23	9850N-05016	..SCREW, PAN HEAD	2				
24	9850N-04010	..SCREW, PAN HEAD	4				
25	J10-H1129-10	.COVER, BRUSH	3				
26	J10-H1139-10	.COVER, BRUSH 2	1				
27	J10-81145-10	.SCREW 1	2				

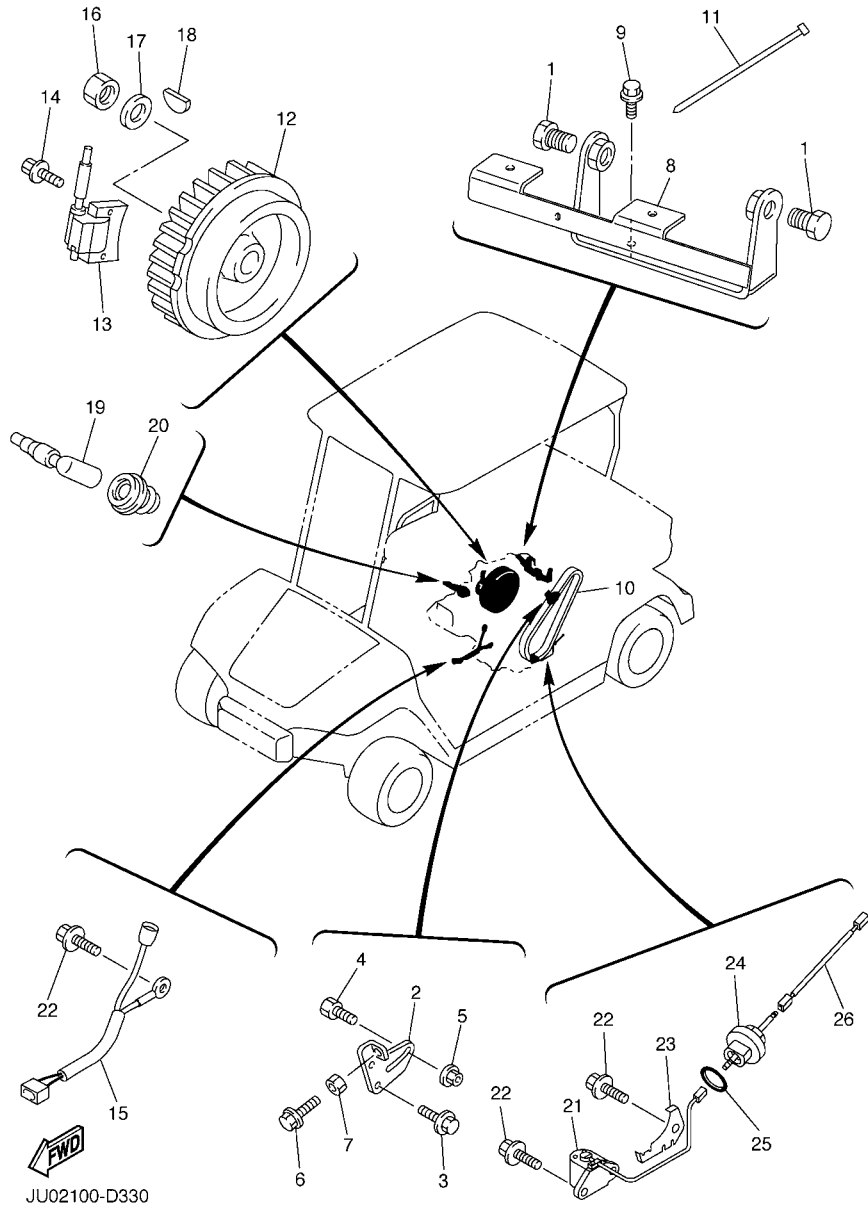

JU02100-D330

FIG. 33 ELECTRICAL 1

REF. NO.	PART NO.	DESCRIPTION	JU02				REMARKS
1	9581P-12025	BOLT, FLANGE	2				
2	JN6-H1170-00	TENSIONER ASSY	1				
3	9582P-08020	BOLT, FLANGE	2				
4	90109-08875	BOLT	1				
5	95707-08500	NUT, FLANGE	1				
6	90101-06478	BOLT	1				
7	95307-06600	NUT	1				
8	JN6-H1171-00	BRACKET, STARTER GENERATOR	1				
9	9582P-08020	BOLT, FLANGE	2				
10	JN6-H1173-00	BELT	1				
11	90464-09823	CLAMP	1				
12	JR7-85650-00	ROTOR ASSY	1				
13	JN6-85640-01	T.C.I. UNIT ASSY	1				
14	95827-06025	BOLT, FLANGE	2				
15	JN6-82318-00	WIRE, SUB-LEAD	1				
16	95307-18600	NUT	1				
17	90201-18620	WASHER, PLATE	1				
18	90280-04052	KEY, WOODRUFF	1				
19	JN6-82370-00	PLUG CAP ASSY	1				
20	JE8-82372-00	SEAL, PLUG CAP	1				
21	JT0-85720-00	OIL LEVEL GAUGE ASSY	1				
22	95827-06012	BOLT, FLANGE	4				
23	JT0-85724-00	CLAMP	1				
24	JT0-15362-00	PLUG, OIL LEVEL	1				
25	93210-15414	O-RING	1				
26	JT0-8231Y-00	WIRE, LEAD	1				

D15

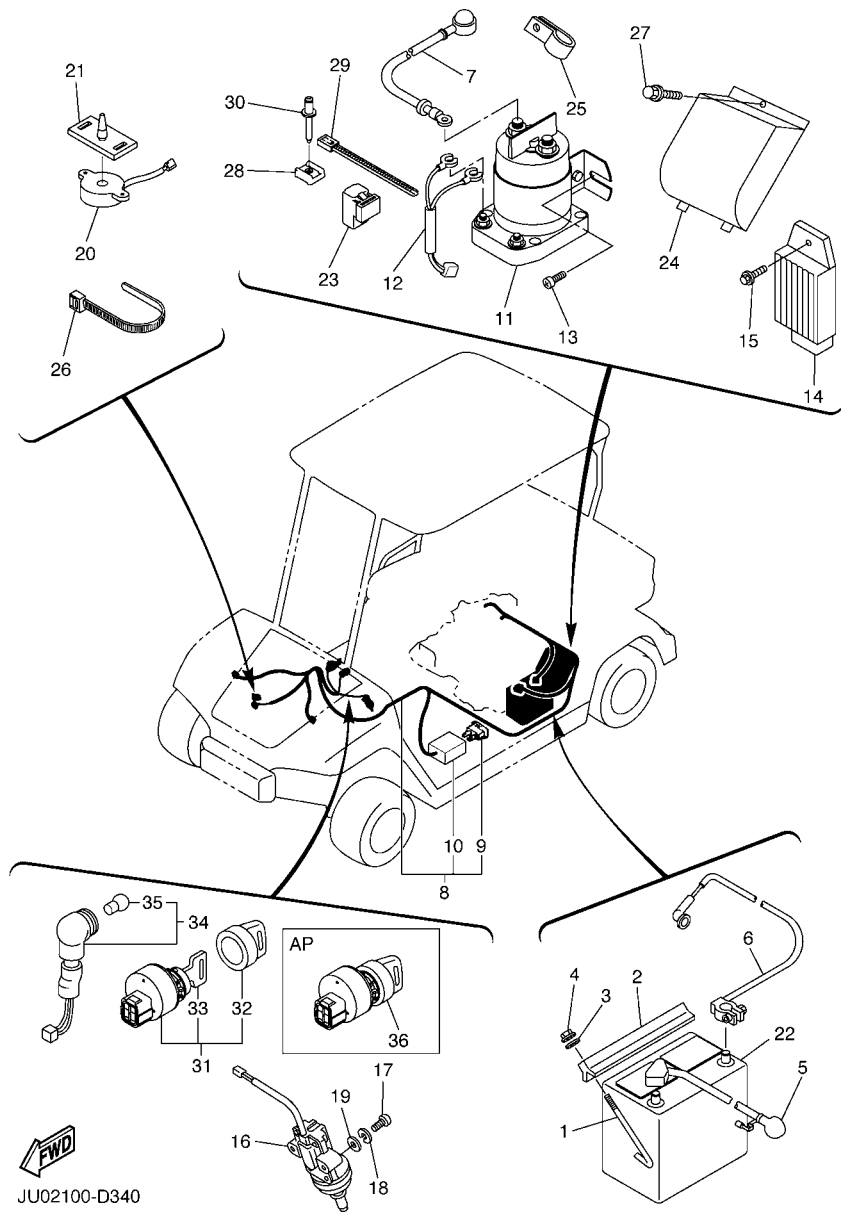

JU02100-D340

FIG. 34 ELECTRICAL 2

REF. NO.	PART NO.	DESCRIPTION	JU02				REMARKS
1	JN3-H2133-00	SCREW, FITTING	2				
2	J55-H2136-00	PLATE, BATTERY FITTING	1				
3	9290P-06200	WASHER	2				
4	95707-06500	NUT, FLANGE	2				
5	JN6-H2115-01	WIRE, PLUS LEAD	1				
6	JN6-H2116-01	WIRE, MINUS LEAD	1				
7	JN6-H2117-10	WIRE, LEAD	1				
8	JU0-H2590-00	WIRE HARNESS ASSY	1				
9	JN6-H2151-00	.FUSE (10 A)	1				
10	JR1-H2150-00	.FUSE HOLDER ASSY	1				
11	JR3-H1950-00	RELAY ASSY	1				
12	JN6-H2105-00	WIRE HARNESS	1				
13	90163-06005	SCREW, TAPPING	2				
14	JF2-81910-01	VOLTAGE REGULATOR ASSY	1				
15	90105-06876	BOLT, FLANGE	1				
16	JF7-82817-20	SWITCH	1				
17	98507-05025	SCREW, PAN HEAD	2				
18	92907-05100	WASHER, SPRING	2				
19	92907-05600	WASHER, PLATE	2				
20	JR1-H3383-01	BUZZER	1				
21	JN6-H3386-01	STAY, BUZZER	1				
22	JG5-H2110-01	BATTERY ASSY (GC-24, 12V)	1				
23	4U8-81950-02	RELAY ASSY	1				
24	JN6-H1942-00	COVER	1				
25	90461-16802	CLAMP	1				
26	90464-40825	CLAMP	4				
27	90105-06876	BOLT, FLANGE	2				

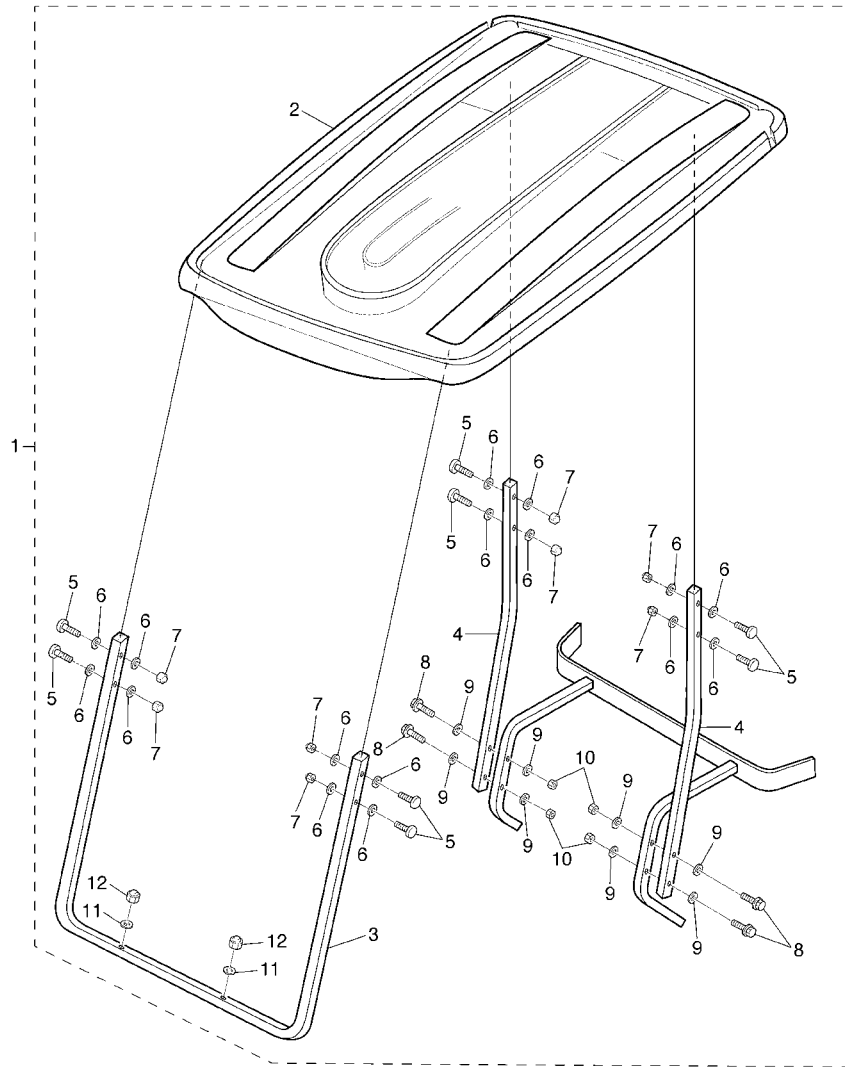

FIG. 36 ALTERNATE FOR SUN ROOF

REF. NO.	PART NO.	DESCRIPTION	JU02				REMARKS
1	JU0-K8310-00	SUN ROOF ASSY	1				UR IVORY
	JU0-K8310-10	SUN ROOF ASSY	1				UR MILKY BROWN
2	JU0-K8314-00	.COVER, SUN ROOF	1				UR IVORY
	JU0-K8314-10	.COVER, SUN ROOF	1				UR MILKY BROWN
3	JU0-K8312-01	.SUPPORT, SUN ROOF 1	1				
4	JU0-K8313-01	.SUPPORT, SUN ROOF 2	2				
5	JU0-K8388-00	.BOLT, ROOF 1	8				
6	90201-088T2	.WASHER, PLATE	16				
7	JU0-K8398-00	.NUT, ROOF 1	8				
8	90101-22864	.BOLT	4				
9	90201-088J3	.WASHER, PLATE	8				
10	90185-12835	.NUT, SELF-LOCKING	4				
11	90201-098J4	.WASHER, PLATE	2				
12	90176-08801	.NUT, CROWN	2				



JU22100-D210

FIG. 37 ALTERNATE FOR LIGHT KIT

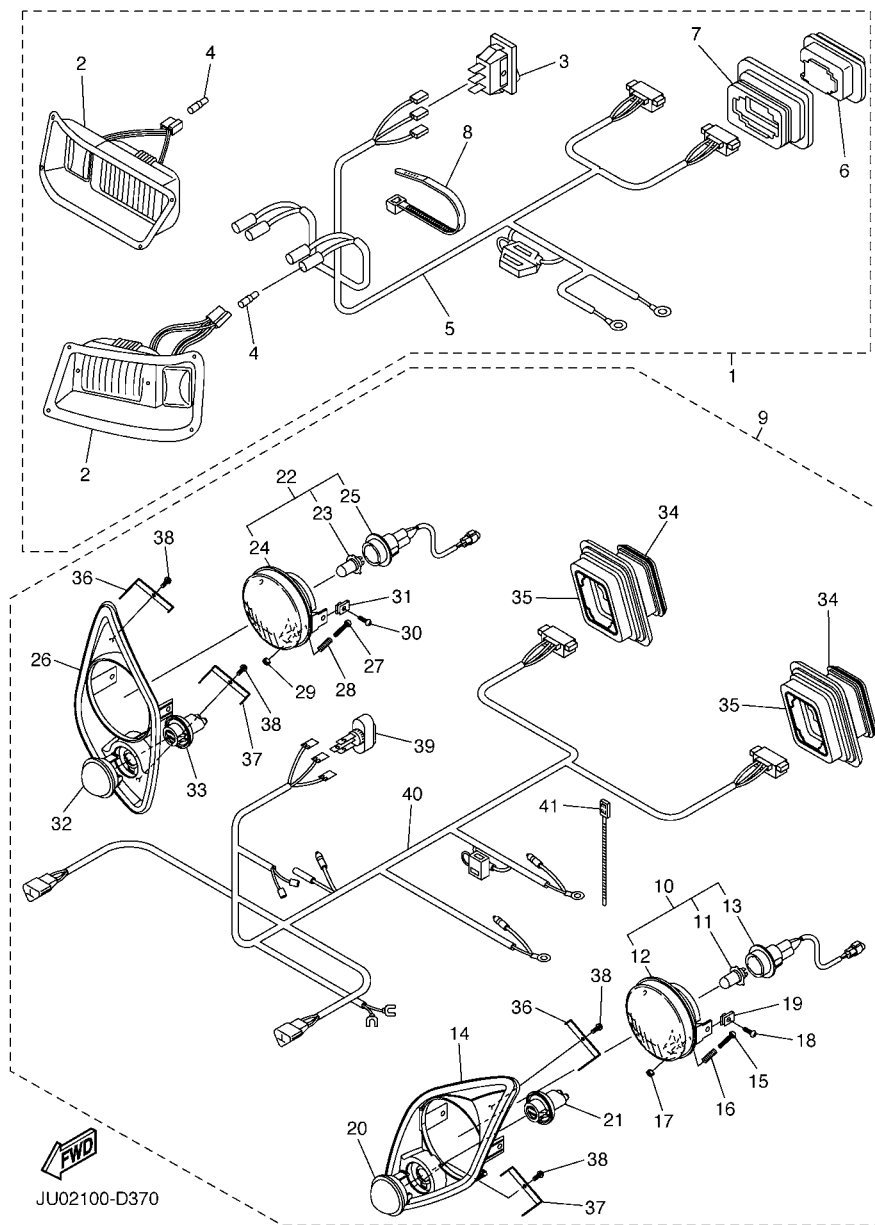

JU02100-D370

REF. NO.	PART NO.	DESCRIPTION	JU02				REMARKS
1	JN6-H430A-20	HEADLIGHT UNIT ASSY	1				UR
2	JN3-H4303-20	.HEADLIGHT UNIT ASSY	2				
3	JN3-H3976-20	.SWITCH, HANDLE 1	1				
4	9E212-10401	.TERMINAL	2				
5	JN6-H4159-00	.CORD, HEADLIGHT	1				
6	JU5-H4700-00	.TAILLIGHT ASSY	2				
7	JU5-H4718-00	.GROMMET	2				
8	90464-40800	.CLAMP	20				
9	JU0-H430A-00	HEADLIGHT UNIT ASSY	1				UR
10	5FU-H4300-00	.HEADLIGHT ASSY	1				
11	5FU-H4314-00	..BULB, HEADLIGHT(12V-30/30W)	1				
12	5FU-H4320-00	..LENS ASSY	1				
13	5FU-H4340-00	..SOCKET CORD ASSY 1	1				
14	JU7-H411T-02	.HOLDER, 1	1				
15	98507-03540	.SCREW, PAN HEAD	1				
16	2GU-84332-00	.SPRING, SCREW	1				
17	2GU-84334-00	.NUT, ADJUSTING	1				
18	90150-05802	.SCREW, ROUND HEAD	2				
19	90183-05008	.NUT, SPRING	2				
20	JU7-H5415-00	.MARK, SIGNAL LAMP	1				
21	JU7-H3547-00	.COVER, SOCKET	1				
22	5FU-H4300-00	.HEADLIGHT ASSY	1				
23	5FU-H4314-00	..BULB, HEADLIGHT(12V-30/30W)	1				
24	5FU-H4320-00	..LENS ASSY	1				
25	5FU-H4340-00	..SOCKET CORD ASSY 1	1				
26	JU7-H411U-02	.HOLDER, 2	1				
27	98507-03540	.SCREW, PAN HEAD	1				

NUMERICAL INDEX

PART NO.	GRID NO.	PART NO.	GRID NO.	PART NO.	GRID NO.	PART NO.	GRID NO.	PART NO.	GRID NO.	PART NO.	GRID NO.
JT0-11111-00	B - 3	7E1-14191-00	B - 8	JF2-46382-00	D - 3	JU0-F3512-01	B - 14	JU0-F6341-00	C - 6	JN3-G6344-20	C - 15
JN6-11116-00	B - 3	1KT-14197-01	B - 8	J38-78367-00	D - 10	JU0-F3521-00	B - 14	JU0-F6351-00	C - 6	JN3-G6344-30	C - 15
JN6-11133-10	B - 3	127-14198-00	B - 8	J10-81145-10	D - 13	JU0-F3570-20	B - 14	JN6-F722E-00	C - 7	JN3-G6344-40	C - 15
JR7-11163-00	B - 3	7NJ-14211-00	B - 8	J10-81148-10	D - 13	JU0-F3811-00	C - 2	JN6-F722F-00	C - 8	JN3-G6344-50	C - 15
JN6-11168-00	B - 3	73A-14212-00	B - 8	JF2-81910-01	E - 2	JN3-F3814-00	C - 2	JU0-F722H-00	C - 13	JN3-G6344-60	C - 15
JN6-11169-00	B - 3	73A-14212-10	B - 8	4U8-81950-02	E - 2	JU0-F3822-00	C - 3	JU0-F723F-00	C - 13	JN3-G6344-70	C - 15
JT0-11181-00	B - 3	J10-14227-00	B - 8	JN6-82318-00	D - 15	JU0-F3828-00	C - 2	JN3-F7245-00	C - 6	JN3-G6344-80	C - 15
JN6-11191-01	B - 3	3G2-1423A-67	B - 8	JT0-8231Y-00	D - 15	JU0-F3833-00	C - 2	JN6-F7280-03	C - 8	JN3-G6344-90	C - 15
JN6-11193-00	B - 3	3G2-1423A-68-A0	B - 8	JN6-82370-00	D - 15	JU0-F3834-00	C - 2		C - 14	JN3-G6344-A0	C - 15
812-11198-00	B - 10	3G2-1423E-33-A0	B - 8	JE8-82372-00	D - 15	JU0-F3837-00	C - 2	JN6-F7286-00	C - 7	JN3-G6344-B0	C - 15
JN6-11400-00	B - 4	JN6-14291-00	B - 8	JN3-82617-01	D - 3	JN3-F3838-00	C - 2		C - 8	JN3-G6344-C0	C - 15
JN6-11454-00	B - 4	7KY-14613-01	B - 9	JF7-82817-20	E - 2	JU0-F3841-00	C - 3	JN6-F7290-03	C - 7	JN3-G6344-D0	C - 15
JR7-11610-00	B - 4	1WG-14922-00	B - 8	123-83516-21	E - 3	JU0-F3844-00	C - 2		C - 14	JN3-G6355-00	C - 13
JR7-11610-10	B - 4	JN6-1495H-3B	B - 8	JN6-83530-00	E - 3	JU0-F3848-00	C - 2	JN6-F7874-01	C - 9	JN3-G6356-00	C - 14
JR7-11610-20	B - 4	JR7-15100-00	B - 10	2GU-84332-00	E - 6	JU0-F3857-00	C - 2	JN6-F819G-00	C - 7	JN3-G6371-00	D - 3
JR7-11631-00-A0	B - 4	JR7-15123-00	B - 10	2GU-84334-00	E - 6	JU0-F387A-00	C - 2		C - 8	JN3-G6372-00	D - 3
583-11633-00	B - 4	JN6-15155-00	B - 10	JN6-85640-01	D - 15	JU0-F387E-00	C - 2	JN3-G6153-00	C - 14	JN3-G6376-00	D - 3
JR7-11635-00	B - 4	J38-15361-00	B - 10	JR7-85650-00	D - 15	JU0-F387F-00	C - 2	JU0-G6164-00	C - 15	JU0-G6376-00	C - 14
JR7-11636-00	B - 4	JT0-15362-00	D - 15	JT0-85720-00	D - 15	JU0-F387G-00	C - 2	JN6-G6201-04	C - 11	JN3-G6381-00	D - 3
JN6-11650-00	B - 4	796-15363-01	B - 10	JT0-85724-00	D - 15	JU0-F387J-00	C - 2	JN6-G6210-00	C - 11	J55-G6383-00	D - 3
JN6-11654-00	B - 4	JR7-15407-00	B - 10	JN6-E1166-00	B - 3	JU0-F387K-00	C - 2	JN6-G621F-00	C - 11	JN3-G638A-00	C - 14
JN6-12111-01	B - 5	JN6-15411-01	B - 10	JN6-E2691-00	B - 6	JU0-F4111-00	C - 4	JN6-G6220-00	C - 11	JN6-G638E-00	C - 14
J38-12117-01	B - 5	JN6-15451-02	B - 10	JU0-E3586-00	B - 7	JU0-F4161-00	D - 5	JU0-G6231-00	C - 11	JN6-G6410-00	C - 13
J38-12118-00	B - 5	JR6-19001-00	B - 2	JU0-E4411-00	B - 7	JU0-F4300-00	C - 4	JN6-G6232-01	C - 11	JN3-G6432-00	C - 13
4G0-12119-00	B - 5	7UH-2111F-00	B - 6	JU0-E4412-00	B - 7	JN6-F4311-20	C - 4	J55-G6241-00	C - 11	JN3-G6511-00	C - 13
7RH-12121-00	B - 5	JT0-21481-00	B - 11	5UH-E4424-00	B - 7	JN6-F4312-20	C - 4	JN6-G6249-00	C - 11	JN3-G6512-00	C - 13
JN6-12151-00	B - 5	JR6-2179R-01	B - 6	JU0-E4450-00	B - 7	JN6-F4313-20	C - 4	JN6-G6251-01	C - 11	JN3-G6514-00	C - 14
JN6-12153-00	B - 5	401-22128-01	B - 14	JU0-E445E-00	B - 7	JN6-F4314-20	C - 4	JN6-G6253-00	C - 11	JU0-G6521-00	D - 2
JR7-12154-01	B - 5	J55-2252M-00	C - 6	JU0-E4710-10	B - 9	JU5-F4375-00	C - 4	JN6-G6258-02	C - 11	JN6-G6555-00	C - 13
J38-12156-00	B - 5	2NL-23448-00	B - 14	JN6-E7688-00	C - 12	JN6-F4410-10	C - 4	JN6-G6260-00	C - 12	JN3-G6556-00	C - 14
22F-12159-00	B - 5	2NL-23517-00	B - 14	JU0-F1338-00	C - 2	JN6-F4560-00	C - 4	JN6-G6270-01	C - 12	JN3-G8330-00	D - 3
JR7-12170-00	B - 5	2HR-23526-00	B - 14	JU0-F1436-00	B - 9	JN6-F4610-00	C - 4	JN6-G6271-02	C - 12	JN6-H1100-03	D - 13
JN6-12616-00	B - 6	J17-25666-02	C - 5	JU0-F2110-10	B - 12	JU0-F5100-00	B - 15	JN6-G6280-00	C - 12	JN6-H1110-10	D - 13
JN6-12621-02	B - 6	JU0-25671-00	C - 5	JN6-F2123-10	B - 12		D - 2	JU0-G6290-00	C - 15	JF2-H1111-00	D - 13
JN6-12651-00	B - 6	J17-25672-01	C - 5	JN6-F2124-10	B - 12	JN6-F5100-11	B - 15	JU0-G6297-00	C - 11	JN6-H1113-00	D - 13
JN6-12652-00	B - 6	J17-25673-00	C - 5	JN6-F217G-00	B - 12		D - 2	JU0-G6300-10	C - 13	J10-H1115-10	D - 13
JR7-12658-00	B - 6	JU0-27211-01	C - 5	JN4-F2210-00	B - 12	JN6-F5118-00	B - 15	JN3-G6313-00	C - 13	JN6-H1119-00	D - 13
JN6-13567-00	B - 7	J17-27221-00	C - 5	JU0-F2501-00	B - 13		D - 2	JN3-G6314-00	C - 13	J10-H1129-10	D - 13
JN6-13595-00	B - 7	J17-27228-00	C - 5	JU0-F254R-00	B - 13	JN6-F5331-01	C - 7	JN3-G6316-00	C - 14	J10-H1139-10	D - 13
JR6-14101-00	B - 8	J17-27231-03	C - 5	JU0-F2567-00	B - 13	JN6-F5341-01	C - 8	JN3-G6319-00	C - 15	J10-H1146-10	D - 13
7LV-14118-00	B - 8	J17-27232-00	C - 5	JU0-F2966-00	C - 2	JU0-F5418-00	C - 3	JU0-G631A-00	C - 13	J10-H1147-10	D - 13
732-14142-65-A0	B - 8	J17-27246-00	C - 6	JU0-F3183-00	C - 2	JN6-F5681-00	C - 6	JN3-G6320-01	C - 13	JN3-H1150-00	D - 13
73A-1414G-00	B - 8	J46-27250-03	C - 5	JU0-F3350-20	B - 14	JN6-F5685-00	C - 6	JN3-G6326-00	C - 14	J10-H1157-10	D - 13
JN5-14150-00	B - 8	J17-27853-01	C - 9	JU0-F3390-20	B - 14	JU0-F582M-00	C - 2	JN3-G6327-00	C - 14	J10-H1158-10	D - 13
7R1-14162-00	B - 8	J10-27871-01	C - 9	JN6-F3394-00	C - 4	JN3-F6311-00	C - 9	JN3-G633E-01	C - 13	J10-H1159-10	D - 13
796-14184-00	B - 8	J38-27872-00	C - 9	JU0-F339Y-00	C - 2	JN6-F6312-01	B - 7	JN3-G633G-00	C - 13	JN6-H1160-10	D - 13
JN6-14185-00	B - 8	J38-27951-00	C - 10	JU0-F3400-00	C - 2	JN6-F6331-11	B - 7	JN3-G6344-00	C - 14	JN6-H1161-00	D - 14
22F-14186-00	B - 8	J38-27959-00	C - 10	JU0-F3511-00	B - 14	JN6-F6333-10	B - 7	JN3-G6344-10	C - 15	JN6-H1165-00	D - 13

NUMERICAL INDEX

PART NO.	GRID NO.	PART NO.	GRID NO.	PART NO.	GRID NO.	PART NO.	GRID NO.	PART NO.	GRID NO.	PART NO.	GRID NO.
J10-H1166-10	D - 13	JU0-K7222-01	E - 4	JU0-K8251-00	D - 8	JF2-K8427-00	D - 11	90170-08841	C - 14	90209-32832	B - 15
JN6-H1170-00	D - 15	JU0-K7458-00	E - 4	JU0-K8252-00	D - 8	JN3-K842A-00	D - 7	90170-10840	C - 13	90249-14129	C - 6
JN6-H1171-00	D - 15	JN3-K7510-02	D - 4	JU0-K8261-00	D - 5	JN3-K842H-00	D - 11	90176-08801	E - 5	90267-48086	D - 9
JN6-H1173-00	D - 15	JN6-K7540-00	D - 4	JF2-K8262-01	D - 5	JG5-WF511-10	B - 14	90179-07564	C - 5	90267-48154	D - 9
JN3-H1661-00	D - 14	JU0-K7573-00	D - 5	JF2-K8263-01	D - 5	90101-06478	D - 15	90179-08879	B - 9	90267-48831	D - 9
JN6-H1942-00	E - 2	JN3-K7741-00	D - 7	JN6-K8264-00	D - 5	90101-06865	D - 10	90179-08894	C - 6	90267-489U9	E - 3
JR3-H1950-00	E - 2	JU0-K7762-00	C - 3	JN6-K8265-00	D - 5	90101-06876	D - 7	90179-12262	B - 15	90267-63047	D - 6
JN6-H2105-00	E - 2	JU0-K7762-10	C - 3	JN6-K8271-00	D - 9	90101-08855	C - 14		D - 2		D - 8
JG5-H2110-01	E - 2	JU0-K7762-20	C - 3	JN3-K8273-00	D - 5	90101-08856	C - 13	90179-13878	B - 12	90269-06804	D - 7
JN6-H2115-01	E - 2	JN3-K7768-00	D - 5	JN3-K8297-10	D - 8	90101-10854	C - 13	90179-16889	D - 14	90269-07810	D - 7
JN6-H2116-01	E - 2	JN3-K7768-10	D - 5	JN3-K8299-10	D - 8	90101-10884	C - 6	90183-05008	E - 6	90269-08066	D - 5
JN6-H2117-10	E - 2	JN3-K7768-20	D - 5	JU0-K8310-00	E - 5	90101-22864	E - 5	90183-06811	D - 7	90269-08813	B - 6
JN3-H2133-00	E - 2	JF2-K8114-03	D - 5	JU0-K8310-10	E - 5	90105-06861	C - 11	90185-06834	C - 11		D - 7
J55-H2136-00	E - 2	JU0-K8115-00	D - 5	JU0-K8312-01	E - 5	90105-06862	B - 7	90185-06836	D - 5	90280-04052	D - 15
JR1-H2150-00	E - 2	JU0-K8115-30	D - 5	JU0-K8313-01	E - 5	90105-06876	D - 3		D - 10	90280-05022	C - 12
JN6-H2151-00	E - 2	JU0-K8115-50	D - 5	JU0-K8314-00	E - 5		D - 4	90185-08832	D - 10	90338-04840	C - 11
JU2-H2510-10	E - 3	JU0-K8115-60	D - 5	JU0-K8314-10	E - 5		E - 2	90185-08841	B - 9	90338-05829	D - 9
JU2-H2510-20	E - 3	JU0-K8115-71	D - 5	JN3-K832F-00	B - 13	90105-06903	D - 11	90185-12061	C - 2	90338-05834	D - 7
JU2-H2511-00	E - 3	JU0-K8115-80	D - 5	JN6-K8340-00	D - 10	90105-08859	C - 13	90185-12835	E - 5	90338-09828	D - 12
5UG-H2579-00	E - 3	JF2-K811V-00	D - 5	JU0-K8344-00	B - 13	90105-08871	D - 12	90185-16833	C - 14	90340-12097	B - 10
JU0-H2590-00	E - 2	JN6-K8121-00	D - 11	JN6-K8355-00	D - 10	90105-08878	C - 4	90201-048R5	C - 3	90381-17067	B - 14
JR1-H3383-01	E - 2	JN6-K8122-02	D - 11	JF2-K8356-00	D - 10		C - 6	90201-06829	D - 5	90381-18001	B - 14
JN6-H3386-01	E - 2	JN6-K8142-02	D - 7	JN3-K8357-00	C - 3		C - 9	90201-068G0	D - 11	90384-10162	C - 5
JU7-H3547-00	E - 6	JU0-K8142-32	D - 7	JN6-K8358-01	C - 3	90105-10064	B - 14	90201-068G6	D - 11	90384-14080	C - 5
JU0-H3976-00	E - 7	JN6-K8142-52	D - 7	JN6-K835E-00	D - 5	90105-10728	B - 14	90201-068G7	D - 7		C - 9
JN3-H3976-20	E - 6	JU0-K8142-62	D - 7	JN3-K835G-00	D - 5	90105-10810	C - 3	90201-068H0	D - 7	90384-20824	C - 12
JU7-H4118-01	E - 7	JU0-K8142-73	D - 7	JN6-K8361-00	D - 11	90105-10840	C - 13	90201-088J3	E - 5	90384-27823	C - 11
JU7-H4119-01	E - 7	JU0-K8142-82	D - 7	JU0-K8362-00	D - 11	90105-10881	D - 4	90201-088R9	D - 10	90386-08141	C - 10
JU7-H411T-02	E - 6	JU0-K8151-00	D - 7	JN3-K8363-00	D - 7	90105-10890	B - 14	90201-088S2	C - 4	90387-046N7	C - 3
JU7-H411U-02	E - 6	JN3-K815G-00	D - 5	JN6-K8380-00	D - 10	90105-13864	B - 12	90201-088T2	E - 5	90387-068T4	C - 9
JN6-H4159-00	E - 6	JU0-K8164-00	D - 4	JU0-K8382-00	E - 4	90106-08806	C - 9	90201-098J4	D - 11	90387-08013	C - 5
JU0-H4159-00	E - 7	JN3-K8174-00	D - 4	JU0-K8388-00	E - 5	90109-06860	C - 11		E - 5	90387-08014	C - 5
5FU-H4300-00	E - 6	JN6-K8182-00	D - 6	JU0-K838A-10	E - 4	90109-08875	D - 15	90201-104G8	C - 6	90387-107F8	C - 6
JN3-H4303-20	E - 6	JF2-K8187-00	D - 9	JU0-K838A-20	E - 4	90110-04834	C - 12	90201-108P8	B - 14	90387-12009	C - 5
JU0-H430A-00	E - 6	JF2-K8189-00	D - 9	JU0-K838B-00	E - 4	90110-06837	D - 7	90201-11800	B - 13	90387-12016	B - 14
JN6-H430A-20	E - 6	JU0-K818A-00	D - 9	JU0-K8398-00	E - 5	90111-06810	D - 11	90201-128S4	B - 12	90387-241M7	B - 14
5FU-H4314-00	E - 6	JU0-K818B-00	D - 9	JU0-K8401-00	D - 11	90111-08803	D - 10	90201-128S5	C - 12	90461-16802	E - 2
5FU-H4320-00	E - 6	JF2-K8191-01	D - 9	JN6-K8401-10	D - 11	90114-12800	B - 14	90201-178H8	C - 14	90464-09823	D - 15
5FU-H4340-00	E - 6	JF2-K8192-01	D - 9	JN3-K8402-00	D - 11	90114-12804	C - 14	90201-18620	D - 15	90464-11816	C - 4
JU5-H4700-00	E - 6	JF2-K8215-10	D - 9	JU0-K8402-00	D - 11	90119-06838	B - 7	90201-198S7	D - 3	90464-14806	E - 7
JU5-H4718-00	E - 6	JF2-K821F-10	D - 9	JU0-K8404-00	D - 11	90119-08820	D - 11	90201-208H9	C - 14	90464-19815	C - 6
JU7-H5415-00	E - 6	JN6-K8231-01	D - 8	JN6-K8404-10	D - 11	90119-08825	B - 9	90201-208J0	C - 14		D - 3
JU0-K7171-00	E - 4	JN6-K8232-01	D - 7	JN3-K8413-00	D - 11	90150-05802	E - 6	90201-208S8	D - 3	90464-40800	E - 6
JU0-K7173-00	E - 4	JN6-K8233-01	D - 8	JN3-K841G-09	D - 11	90159-06107	B - 10	90201-228K5	C - 11	90464-40825	C - 9
JU0-K7200-03	E - 4	JF2-K8237-00	D - 7	JU0-K841G-09	D - 11	90159-06845	D - 10	90202-12807	C - 14		E - 2
JU0-K7200-13	E - 4	JN3-K8243-00	D - 7	JU0-K8423-00	D - 11	90163-06005	E - 2	90202-20130	C - 12	90465-06038	D - 3
JU0-K7200-22	E - 4	JN3-K8244-00	D - 7	JN3-K8425-00	D - 7	90167-04815	D - 11	90204-06807	D - 11	90467-10846	C - 4
JU0-K7200-32	E - 4	JN6-K824E-00	D - 7	JN3-K8426-01	D - 11	90170-05302	B - 5	90207-05800	E - 3	90467-12845	C - 4

NUMERICAL INDEX

PART NO.	GRID NO.	PART NO.	GRID NO.	PART NO.	GRID NO.	PART NO.	GRID NO.	PART NO.	GRID NO.	PART NO.	GRID NO.
90467-13847	B - 3	93101-28831	C - 11	9560P-06200	D - 5	9850N-05018	D - 14				
90468-10049	B - 7	93102-25868	C - 13	9560P-08200	D - 11	99001-07600	B - 7				
	C - 9	93102-30083	B - 15	9560P-10200	B - 11		C - 5				
90480-25856	B - 13	93102-35014	B - 10	9560P-12200	B - 12	99001-09600	C - 6				
90501-264A9	B - 5	93104-11829	C - 14	9561P-12100	B - 14	99002-04600	C - 5				
90502-10013	C - 3	93109-10820	C - 14	95627-08618	B - 3	99009-19400	D - 3				
90506-09001	C - 5	93109-20069	C - 12	95707-06500	C - 9	99530-08016	B - 10				
90506-26282	C - 9	93210-132A8	C - 6		E - 2	99530-14016	B - 3				
90508-14548	C - 5	93210-14104	C - 9	95707-08500	B - 7	9E212-10401	E - 6				
90508-16460	C - 9	93210-15414	D - 15		C - 9						
90508-32015	C - 6	93210-22344	B - 10		D - 2						
90508-40007	C - 6	93210-398D6	B - 7		D - 15						
90508-40678	C - 10	93306-004X5	C - 14	9572R-06300	D - 7						
90508-45844	C - 12	93306-005Y3	B - 14	95807-06020	B - 6						
90560-05001	C - 9	93306-005Y4	C - 13	95807-06025	C - 9						
90560-08251	C - 4	93306-007Y0	C - 13	95807-08016	B - 13						
91401-20012	D - 3	93306-20201	B - 10	95807-10055	B - 12						
91401-25020	B - 14	93306-204X0	B - 14	95807-10065	B - 14						
	C - 2	93306-20714	B - 10	95817-08045	B - 10						
91490-25015	C - 6	93306-303Y6	C - 13	95817-10050	B - 10						
91490-25025	C - 13	93306-30709	B - 10	95817-10070	B - 3						
91490-30015	C - 6	93410-12822	C - 14	95817-12080	B - 14						
91609-35028	C - 9	93410-25017	C - 15	9581P-08012	D - 4						
91609-60028	C - 9	93420-44805	C - 13	9581P-08016	C - 2						
91701-05010	B - 7	93440-20813	C - 14	9581P-08075	D - 2						
91701-05012	C - 9	93450-21053	B - 4	9581P-12025	D - 15						
91701-06014	D - 3	93606-10842	C - 14	9581P-12065	B - 12						
91701-08018	C - 6	93610-358A3	C - 11	95827-06012	D - 15						
91701-08026	C - 6	93700-06809	C - 12	95827-06025	D - 15						
91701-10022	C - 6	93700-06810	C - 11	95827-06030	B - 3						
92902-04100	B - 8	94702-00343	B - 3	9582P-08020	D - 15						
92907-04100	D - 3	94702-00348	B - 3	95880-06025	D - 11						
92907-04600	D - 3	95307-06600	C - 10	97017-08030	C - 3						
92907-05100	E - 2		D - 15	97027-06035	C - 5						
92907-05600	C - 5	95307-06700	C - 5	97027-08100	C - 5						
	E - 2	95307-08600	C - 5	9751P-10620	B - 12						
92907-08200	C - 5	95307-08700	C - 6		D - 2						
92907-08600	C - 3	95307-18600	D - 15	97707-40112	E - 7						
92907-10600	C - 5	9530N-06600	D - 13	97707-40525	C - 3						
9290N-06100	D - 13	95607-08100	D - 3	97707-60520	B - 6						
9290N-06600	D - 13	95607-08710	B - 3	9770P-60130	D - 5						
9290P-06200	E - 2	95607-10200	B - 12	98507-03540	E - 6						
9290P-06600	D - 3		B - 14	98507-04010	B - 8						
9290P-10200	B - 11		C - 6	98507-04016	D - 3						
9290P-12200	C - 2	95607-12200	C - 2	98507-05008	B - 8						
92990-05100	B - 8		C - 12	98507-05025	E - 2						
9299R-06200	D - 10	95607-14100	B - 15	9850N-04010	D - 13						
93101-24822	C - 13	9560P-06200	C - 10	9850N-05016	D - 13						